

# SEA

ISO 18

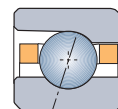

SEA





SEA

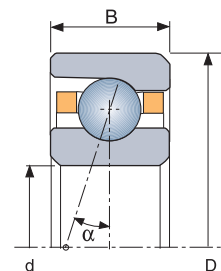

SNFA	d	D	B	z	Ø	$\alpha = 15^\circ$		$\alpha = 25^\circ$		Öl	Fett	Masse
						C33	Co	C33	Co	Vh (ABEC 9)	Vh (ABEC 9)	
SEA 10	10	19	5	12	2.38	190	125	185	119	121 000	78 700	0.005
SEA 12	12	21	5	14	2.38	210	150	200	143	106 000	69 000	0.006
SEA 15	15	24	5	17	2.38	235	189	220	179	89 500	58 200	0.007
SEA 17	17	26	5	18	2.38	240	200	230	193	81 000	52 700	0.010
SEA 20	20	32	7	17	3.17	390	340	370	320	66 500	43 300	0.018
SEA 25	25	37	7	20	3.17	420	410	400	390	55 500	36 100	0.021
SEA 30	30	42	7	23	3.17	450	480	425	450	48 000	31 200	0.026
SEA 35	35	47	7	26	3.17	470	550	445	520	41 500	27 000	0.028
SEA 40	40	52	7	29	3.17	490	620	465	590	36 500	23 800	0.031
SEA 45	45	58	7	31	3.17	500	670	470	630	33 000	21 500	0.039
SEA 50	50	65	7	30	3.97	750	1 000	710	950	29 500	19 200	0.051
SEA 55	55	72	9	29	4.76	1 045	1 380	985	1 310	26 000	16 900	0.081
SEA 60	60	78	10	28	5.55	1 370	1 800	1 290	1 700	24 000	15 600	0.100
SEA 65	65	85	10	29	5.55	1 375	1 890	1 295	1 780	22 000	14 300	0.126
SEA 70	70	90	10	31	5.55	1 410	2 030	1 330	1 920	20 500	13 300	0.134
SEA 75	75	95	10	33	5.55	1 450	2 170	1 365	2 050	19 400	12 600	0.142
SEA 80	80	100	10	35	5.55	1 485	2 320	1 395	2 180	17 800	11 600	0.151
SEA 85	85	110	13	30	7.14	2 200	3 220	2 070	3 040	16 700	10 900	0.266
SEA 90	90	115	13	31	7.14	2 210	3 350	2 090	3 160	15 600	10 100	0.279
SEA 95	95	120	13	32	7.14	2 245	3 470	2 110	3 280	15 000	9 800	0.292
SEA 100	100	125	13	34	7.14	2 305	3 710	2 165	3 500	14 400	9 400	0.310
SEA 105	105	130	13	35	7.14	2 320	3 830	2 180	3 610	13 600	8 800	0.320
SEA 110	110	140	16	32	8.73	3 235	5 200	3 041	4 880	12 800	8 300	0.505
SEA 120	120	150	16	35	8.73	3 365	5 700	3 160	5 400	11 700	7 600	0.550
SEA 130	130	165	18	35	9.53	3 920	6 800	3 690	6 400	10 600	6 900	0.770
SEA 140	140	175	18	35	10.32	4 550	7 900	4 270	7 500	9 800	6 400	0.800
SEA 150	150	190	20	35	11.11	5 200	9 200	4 880	8 700	9 000	5 900	1.100

Größere Abmessungen auf Anfrage.

Referenzdrehzahlen Vh für Schrägkugellager mit  $\alpha = 15^\circ$  und Federvorspannung  
Berechnung der Drehzahlgrenzen von Lagersätzen siehe Seite 27.

**Vospannungs- und Steifigkeitswerte**  
(fest vorgespannt)  
Druckwinkel = 15°

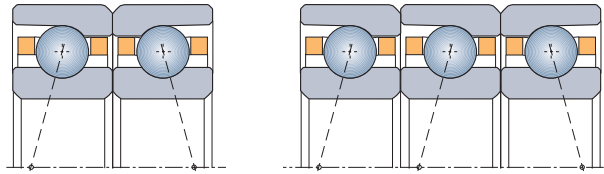

ISO 18

SEA

SNFA	Leichte Vorspannung L			Mittlere Vorspannung M			Starke Vorspannung F		
	Pr	Ra		Pr	Ra		Pr	Ra	
		Paar	Dreier		Paar	Dreier		Paar	Dreier
SEA 10	1.0	1.0	1.5	3.0	1.5	2.2	6.0	1.9	2.8
SEA 12	1.1	1.2	1.7	3.3	1.7	2.5	6.6	2.2	3.2
SEA 15	1.2	1.4	2.1	3.6	2.0	3.0	7.2	2.5	3.7
SEA 17	1.2	1.5	2.1	3.7	2.1	3.1	7.5	2.7	3.9
SEA 20	2.0	1.8	2.7	6.0	2.6	3.9	12.0	3.3	4.9
SEA 25	2.2	2.1	3.1	6.6	3.0	4.4	13.2	3.8	5.6
SEA 30	2.3	2.3	3.4	7.0	3.4	5.0	14.0	4.3	6.3
SEA 35	2.5	2.6	3.8	7.5	3.7	5.5	15.0	4.7	7.0
SEA 40	2.6	2.8	4.2	7.8	4.1	6.0	15.5	5.1	7.6
SEA 45	2.7	3.0	4.4	8.0	4.3	6.3	16.0	5.4	8.0
SEA 50	4.0	3.6	5.3	12.0	5.2	7.7	24.0	6.5	9.6
SEA 55	5.5	4.2	6.1	16.5	6.0	8.8	33.0	7.5	11.1
SEA 60	7.0	4.7	6.8	21.0	6.7	9.9	42.0	8.4	12.4
SEA 65	7.1	4.8	7.0	21.5	7.0	10.2	43.0	8.7	12.8
SEA 70	7.3	5.0	7.4	22.0	7.3	10.7	44.0	9.2	13.5
SEA 75	7.6	5.4	7.8	22.5	7.7	11.2	45.0	9.6	14.2
SEA 80	7.8	5.7	8.2	23.5	8.1	11.9	47.0	10.2	15.0
SEA 85	11.5	6.2	9.2	34.5	9.0	13.2	69.0	11.3	16.7
SEA 90	11.6	6.4	9.4	35.0	9.2	13.6	70.0	11.6	17.1
SEA 95	11.7	6.6	9.6	35.5	9.5	13.9	71.0	11.9	17.6
SEA 100	12.0	6.9	10.1	36.0	9.9	14.6	72.0	12.5	18.4
SEA 105	13.0	7.2	10.6	39.0	10.4	15.3	78.0	13.1	19.3
SEA 110	16.0	7.7	11.4	50.0	11.3	16.7	100.0	14.3	21.0
SEA 120	18.0	8.5	12.6	55.0	12.4	18.3	110.0	15.6	23.0
SEA 130	20.5	9.2	13.6	61.5	13.3	19.6	123.0	16.8	24.7
SEA 140	24.0	10.0	14.7	72.0	14.4	21.2	144.0	18.2	26.7
SEA 150	27.0	10.6	15.7	82.0	15.4	22.7	163.0	19.4	28.5



## Vorspannungs- und Steifigkeitswerte (fest vorgespannt) Druckwinkel = 25°

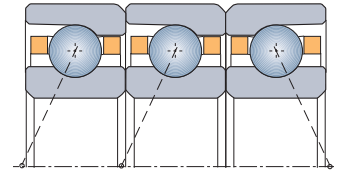
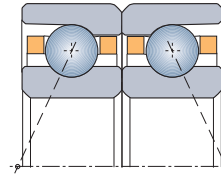

SNFA	Leichte Vorspannung L			Mittlere Vorspannung M			Starke Vorspannung F		
	Pr	Ra		Pr	Ra		Pr	Ra	
		Paar	Dreier		Paar	Dreier		Paar	Dreier
SEA 10	1.6	2.8	4.0	4.8	4.0	5.8	10.0	5.1	7.5
SEA 12	1.7	3.2	4.6	5.3	4.5	6.7	10.5	5.7	8.4
SEA 15	1.9	3.8	5.4	5.8	5.5	7.8	11.5	6.8	9.9
SEA 17	2.0	4.0	5.7	6.0	5.7	8.2	12.0	7.1	10.4
SEA 20	3.2	4.9	7.1	10.0	7.0	10.4	20.0	9.0	13.1
SEA 25	3.5	5.8	8.1	10.5	8.0	11.7	21.0	10.0	14.8
SEA 30	3.7	6.6	9.1	11.0	8.9	13.1	22.0	11.3	16.5
SEA 35	3.9	6.9	10.0	11.5	9.8	14.4	23.0	12.5	18.2
SEA 40	4.0	7.5	10.9	12.0	11.0	15.7	24.0	13.5	19.8
SEA 45	4.1	8.2	11.5	12.5	11.8	16.7	25.0	14.4	21.0
SEA 50	6.0	9.4	13.8	18.0	13.3	19.8	36.0	16.9	25.0
SEA 55	8.7	11.1	16.2	26.0	15.9	23.3	52.0	20.0	29.3
SEA 60	11.4	12.3	18.2	34.0	17.8	26.2	68.0	22.6	33.0
SEA 65	11.5	13.0	18.7	34.5	18.4	26.9	69.0	23.2	33.9
SEA 70	11.7	13.7	19.6	35.0	19.3	28.3	70.0	24.4	35.7
SEA 75	12.0	14.2	20.7	36.0	20.4	29.8	72.0	25.4	37.5
SEA 80	12.3	15.0	21.7	37.0	21.4	31.3	74.0	26.8	39.4
SEA 85	18.3	16.6	24.3	55.0	23.9	35.0	110.0	30.1	44.1
SEA 90	18.4	17.3	24.8	55.5	24.5	35.9	111.0	30.8	45.1
SEA 95	18.6	17.5	25.5	56.0	25.1	36.7	112.0	31.6	46.3
SEA 100	19.0	18.5	26.7	57.0	26.4	38.5	114.0	32.2	48.5
SEA 105	20.0	18.8	27.7	60.0	27.2	40.0	120.0	34.2	50.3
SEA 110	26.0	20.6	30.4	80.0	30.1	44.2	160.0	37.9	55.8
SEA 120	28.0	22.5	33.1	85.0	32.6	47.9	170.0	41.0	60.4
SEA 130	32.5	24.4	35.8	98.0	35.2	51.8	196.0	44.3	65.3
SEA 140	38.0	26.4	38.8	114.0	38.0	55.9	228.0	47.9	70.5
SEA 150	43.0	28.2	41.4	130.0	40.7	59.9	259.0	51.2	75.4

# SEB

ISO 19

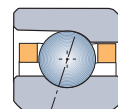

SEB





ISO 19

SEB

SEB

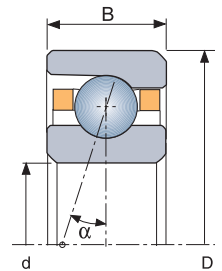

SNFA	d	D	B	z	Ø	$\alpha = 15^\circ$		$\alpha = 25^\circ$		Öl	Fett	Masse
						C33	Co	C33	Co	Vh	Vh	
										(ABEC 9)	(ABEC 9)	
SEB 17	17	30	7	13	3.97	510	370	485	350	74 000	48 100	0.016
SEB 20	20	37	9	14	4.76	745	580	705	550	60 500	39 300	0.036
SEB 25	25	42	9	15	4.76	765	650	735	620	51 000	33 200	0.042
SEB 30	30	47	9	17	4.76	815	750	765	720	44 500	28 900	0.049
SEB 35	35	55	10	18	5.55	1 115	1 090	1 050	1 030	38 000	24 700	0.075
SEB 40	40	62	12	18	6.35	1 420	1 420	1 340	1 350	33 500	21 800	0.110
SEB 45	45	68	12	20	6.35	1 495	1 600	1 415	1 520	30 000	19 500	0.130
SEB 50	50	72	12	21	7.14	1 925	2 110	1 820	2 010	27 000	17 600	0.130
SEB 55	55	80	13	22	7.94	2 415	2 730	2 280	2 590	24 500	15 900	0.178
SEB 60	60	85	13	24	7.94	2 520	3 020	2 375	2 860	23 000	15 000	0.192
SEB 65	65	90	13	25	7.94	2 550	3 180	2 400	3 010	21 000	13 700	0.202
SEB 70	70	100	16	24	9.52	3 515	4 330	3 315	4 110	19 400	12 600	0.338
SEB 75	75	105	16	25	9.52	3 570	4 560	3 360	4 320	17 800	11 600	0.357
SEB 80	80	110	16	26	9.52	3 620	4 780	3 410	4 520	16 700	10 900	0.376
SEB 85	85	120	18	25	11.11	4 735	6 200	4 460	5 900	15 600	10 100	0.532
SEB 90	90	125	18	26	11.11	4 810	6 500	4 530	6 100	14 400	9 400	0.558
SEB 95	95	130	18	27	11.11	4 880	6 800	4 595	6 400	13 900	9 000	0.584
SEB 100	100	140	20	26	12.70	6 145	8 400	5 795	8 000	13 300	8 600	0.801
SEB 110	110	150	20	28	12.70	6 340	9 200	5 970	8 700	12 200	7 900	0.861
SEB 120	120	165	22	26	14.28	7 515	10 700	7 100	10 200	11 100	7 200	1.193
SEB 130	130	180	24	28	14.28	7 750	11 700	7 280	11 100	10 000	6 500	1.628
SEB 140	140	190	24	30	14.28	7 995	12 600	7 540	12 000	8 900	5 800	1.730
SEB 150	150	210	28	24	19.05	12 080	17 500	11 400	16 600	8 300	5 400	2.555
SEB 160	160	220	28	26	19.05	12 610	19 100	11 895	18 100	7 800	5 100	2.713
SEB 170	170	230	28	27	19.05	12 790	20 000	12 050	18 900	7 200	4 700	2.848
SEB 180	180	250	33	25	22.22	16 315	24 900	15 340	23 600	6 700	4 350	4.225
SEB 190	190	260	33	26	22.22	16 560	26 100	15 600	24 700	6 100	3 950	4.410
SEB 200	200	280	38	24	25.40	20 255	31 100	19 160	29 400	5 600	3 650	5.100
SEB 220	220	300	38	26	25.40	20 695	34 100	19 825	32 300	5 000	3 250	6.500
SEB 230	230	310	38	28	25.40	21 800	36 900	20 600	34 900	4 900	3 200	7.000
SEB 240	240	320	38	29	25.40	22 200	38 400	20 900	36 300	4 800	3 100	7.500
SEB 260	260	360	46	26	31.75	29 050	52 900	27 360	50 100	4 300	2 800	12.000
SEB 280	280	380	46	27	31.75	29 300	55 400	27 600	52 500	3 900	2 550	13.000

Größere Abmessungen auf Anfrage.

Referenzdrehzahlen Vh für Schrägkugellager mit  $\alpha = 15^\circ$  und Federvorspannung  
 Berechnung der Drehzahlgrenzen von Lagersätzen siehe Seite 27.

**Vospannungs- und Steifigkeitswerte**  
(fest vorgespannt)  
Druckwinkel = 15°

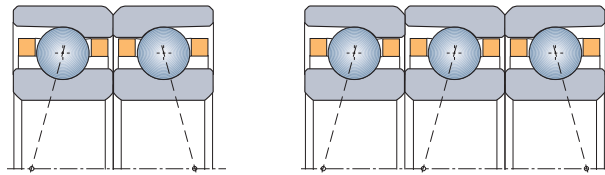

ISO 19

SEB

SNFA	Leichte Vorspannung L			Mittlere Vorspannung M			Starke Vorspannung F		
	Pr	Ra		Pr	Ra		Pr	Ra	
		Paar	Dreier		Paar	Dreier		Paar	Dreier
SEB 17	2.6	1.8	2.6	8.0	2.6	3.8	16.0	3.3	4.8
SEB 20	3.9	2.3	3.4	11.5	3.3	4.8	23.0	4.1	6.1
SEB 25	4.0	2.4	3.6	12.0	3.5	5.1	24.0	4.4	6.5
SEB 30	4.2	2.7	3.9	12.5	3.8	5.6	25.0	4.8	7.1
SEB 35	5.8	3.3	4.8	17.5	4.7	6.9	35.0	5.9	8.7
SEB 40	7.4	3.7	5.4	22.3	5.3	7.8	44.5	6.7	9.9
SEB 45	8.0	4.3	6.0	24.0	6.2	8.6	48.0	7.8	10.8
SEB 50	10.0	4.7	6.9	30.0	6.8	10.0	60.0	8.5	12.5
SEB 55	12.5	5.4	7.9	38.0	7.8	11.5	76.0	9.8	14.5
SEB 60	13.0	5.8	8.5	39.0	8.3	12.3	78.0	10.5	15.5
SEB 65	13.5	6.0	8.8	40.0	8.6	12.8	80.0	10.9	16.0
SEB 70	18.5	6.8	10.1	55.0	9.8	14.7	110.0	12.5	18.5
SEB 75	18.5	7.1	10.5	56.0	10.2	15.1	112.0	12.9	19.0
SEB 80	19.0	7.4	10.8	57.0	10.6	15.7	114.0	13.4	19.7
SEB 85	24.5	8.3	12.2	74.0	11.8	17.6	148.0	15.0	22.1
SEB 90	25.0	8.5	12.5	75.0	12.1	18.1	150.0	15.4	22.7
SEB 95	25.5	8.7	12.9	76.5	12.5	18.7	153.0	15.9	23.4
SEB 100	32.0	9.6	14.2	96.0	13.8	20.5	192.0	17.5	25.8
SEB 110	33.0	10.2	15.1	99.0	14.7	21.8	198.0	18.6	27.4
SEB 120	39.3	10.8	15.8	118.0	15.5	22.8	236.0	19.6	28.8
SEB 130	40.5	11.4	16.8	122.0	16.5	24.3	244.0	20.8	30.6
SEB 140	41.8	12.0	17.8	125.5	17.4	25.6	251.0	22.0	32.3
SEB 150	63.2	13.1	19.4	189.5	19.0	27.9	379.0	23.9	35.2
SEB 160	66.0	14.0	20.7	198.0	20.3	29.9	396.0	25.6	37.6
SEB 170	67.0	14.5	21.3	201.0	20.9	30.8	402.0	26.4	38.8
SEB 180	85.4	15.7	23.1	256.0	22.7	33.4	512.0	28.6	42.0
SEB 190	87.0	16.2	23.9	260.0	23.4	34.4	520.0	29.5	43.4
SEB 200	106.0	17.2	26.1	318.0	24.8	37.2	636.0	31.2	47.0
SEB 220	108.0	18.2	26.9	325.0	26.3	38.8	650.0	33.2	48.9
SEB 230	113.0	19.5	28.6	340.0	28.2	41.4	680.0	35.5	52.2
SEB 240	115.0	20.0	29.5	350.0	29.0	42.7	700.0	36.6	53.8
SEB 260	152.0	22.0	32.4	456.0	31.7	46.7	912.0	40.0	58.9
SEB 280	154.0	22.7	33.4	460.0	32.7	48.1	920.0	41.2	60.6



## Vospannungs- und Steifigkeitswerte (fest vorgespannt) Druckwinkel = 25°

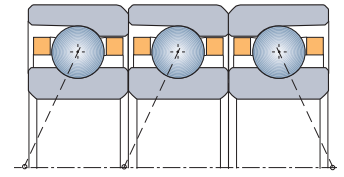
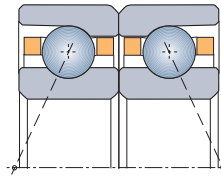

ISO 19

SEB

SNFA	Leichte Vorspannung L			Mittlere Vorspannung M			Starke Vorspannung F		
	Pr	Ra		Pr	Ra		Pr	Ra	
		Paar	Dreier		Paar	Dreier		Paar	Dreier
SEB 17	4.3	4.8	7.0	13.0	6.9	10.2	26.0	8.7	12.8
SEB 20	6.2	6.0	8.9	18.5	8.7	12.8	37.0	11.0	16.1
SEB 25	6.4	6.5	9.4	19.0	9.2	13.5	38.0	11.5	17.0
SEB 30	6.7	7.0	10.4	20.0	9.8	14.9	40.0	12.7	18.8
SEB 35	9.3	8.7	12.7	28.0	12.5	18.3	56.0	15.6	23.0
SEB 40	12.0	10.0	14.4	36.0	14.1	20.8	72.0	17.8	26.2
SEB 45	12.5	10.4	15.7	37.5	16.0	22.6	75.0	19.5	28.5
SEB 50	16.0	12.6	18.3	48.0	17.8	26.4	96.0	22.5	33.2
SEB 55	20.0	14.3	21.1	60.0	20.5	30.5	120.0	26.0	38.3
SEB 60	21.0	15.4	22.7	63.0	22.1	32.9	126.0	28.0	41.3
SEB 65	21.0	15.8	23.4	63.5	22.8	33.8	127.0	28.8	42.5
SEB 70	29.0	18.3	26.9	88.0	26.2	39.0	176.0	33.2	48.9
SEB 75	30.0	18.9	27.8	89.0	27.1	40.3	178.0	34.3	50.6
SEB 80	30.0	19.4	28.7	90.0	27.9	41.5	180.0	35.3	52.0
SEB 85	39.5	21.8	32.2	118.0	31.3	46.5	236.0	39.6	58.4
SEB 90	40.0	22.5	33.2	120.0	32.3	48.1	240.0	40.9	60.3
SEB 95	40.5	23.2	34.3	122.0	33.4	49.6	244.0	42.2	62.2
SEB 100	51.0	25.5	37.7	153.0	36.7	54.6	306.0	46.4	68.4
SEB 110	53.0	27.1	40.0	158.0	39.0	58.0	316.0	49.3	72.7
SEB 120	62.8	28.5	41.9	188.0	41.0	60.4	376.0	51.7	76.1
SEB 130	64.4	30.2	44.4	193.0	43.5	64.0	386.0	54.8	80.6
SEB 140	66.7	32.0	47.0	200.0	46.1	67.8	400.0	58.1	85.5
SEB 150	100.8	34.8	51.2	302.0	50.2	73.8	604.0	63.2	93.0
SEB 160	105.0	37.2	54.7	315.0	53.7	79.0	630.0	67.6	99.5
SEB 170	107.0	38.4	56.5	320.0	55.3	81.4	640.0	69.7	102.5
SEB 180	135.6	41.5	61.1	407.0	60.0	88.2	814.0	75.5	111.1
SEB 190	138.0	43.0	63.1	414.0	61.9	91.0	828.0	78.0	114.7
SEB 200	169.0	45.5	71.0	508.0	65.7	99.5	1 016.0	82.7	127.8
SEB 220	175.0	48.5	71.4	526.0	70.0	103.1	1 052.0	88.3	129.9
SEB 230	182.0	51.7	76.1	545.0	74.5	109.7	1 090.0	93.9	138.2
SEB 240	185.0	53.2	78.3	555.0	76.7	112.9	1 110.0	96.6	142.2
SEB 260	242.0	58.2	85.7	726.0	84.0	123.7	1 452.0	105.8	155.8
SEB 280	244.0	59.9	88.2	732.0	86.4	127.0	1 460.0	109.0	160.0





## Spindellager für Höchstdrehzahlen Serie VEB - HB



Die Lagerreihen VEB (ISO 19) und HB (ISO 19) wurden speziell für den Einsatz bei hohen und extrem hohen Drehzahlen - unabhängig von der Schmierungsart - entwickelt.

Bei der Entwicklung und Produktion dieser Baureihen wurden verschiedene für die Hochgeschwindigkeitsanwendungen ausschlaggebende Einflüsse analysiert, insbesondere Dynamik- und Erwärmungseffekte einschließlich Schmierungsprobleme, ohne dabei die Belastbarkeit und Steifigkeit zu vernachlässigen.

Die in der Tabelle angegebenen Drehzahlwerte gelten bei optimalen Betriebsbedingungen.

Im Falle einer festen Vorspannung reduzieren sich die jeweiligen Werte durch thermisch bedingten Vorspannungsanstieg, wie z.B. durch die vom Elektromotor (Wirbelstromverluste) verursachte Erwärmung.

Maximale Drehzahlen werden durch den Einsatz von VEB- und HB-Lagern in der Ausführung H1/NS (Schmierlöcher im Außenring, Keramikugeln) erreicht.

Um eine optimale Nutzung der Lager zu erreichen, sind folgende Parameter notwendig: minimale Öl-Luft-Schmierung, jedes Lager separat, konstante Vorspannung, genaue Ausführung der Anschlußteile sowie ein hoher dynamischer Auswuchtgrad.

# VEB

## ISO 19

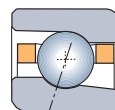

VEB

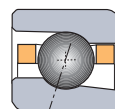

VEB../NS

CERAMIC

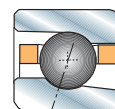

VEB../XN

CHROME<sup>®</sup> 40



ISO 19

VEB

VEB

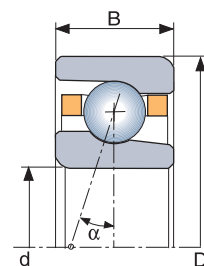

SNFA	d	D	B	z	Ø	$\alpha = 15^\circ$		$\alpha = 25^\circ$		Öl	Fett	Masse
						C33	C0	C33	C0	Vh (ABEC 9)	Vh (ABEC 9)	
VEB 8	8	19	6	9	3.17	178	73			184 000	120 000	0.007
VEB 10	10	22	6	11	3.17	210	95	198	91	155 000	101 000	0.009
VEB 12	12	24	6	12	3.17	220	107	210	102	137 000	89 000	0.010
VEB 15	15	28	7	12	3.97	330	166	310	158	115 000	75 000	0.015
VEB 17	17	30	7	13	3.97	340	184	330	175	105 000	68 200	0.016
VEB 20	20	37	9	14	4.76	500	290	480	270	86 200	56 000	0.036
VEB 25	25	42	9	16	4.76	540	340	510	320	73 100	47 500	0.040
VEB 30	30	47	9	18	4.76	580	390	540	370	63 400	41 200	0.050
VEB 35	35	55	10	19	5.55	790	560	750	540	54 100	35 200	0.075
VEB 40	40	62	12	19	6.35	1 000	740	950	700	47 500	30 900	0.100
VEB 45	45	68	12	21	6.35	1 050	830	1 000	780	42 700	27 700	0.130
VEB 50	50	72	12	21	7.14	1 310	1040	1 240	980	39 500	25 700	0.130
VEB 55	55	80	13	21	7.94	1 590	1 280	1 500	1 220	35 500	23 000	0.170
VEB 60	60	85	13	23	7.94	1 670	1 420	1 580	1 340	33 000	21 500	0.190
VEB 65	65	90	13	24	7.94	1 690	1 500	1 600	1 420	30 800	20 000	0.200
VEB 70	70	100	16	22	9.52	2 260	1 950	2 130	1 850	27 900	18 100	0.320
VEB 75	75	105	16	23	9.52	2 300	2 050	2 170	1 950	26 300	17 100	0.340
VEB 80	80	110	16	24	9.52	2 340	2 160	2 210	2 040	24 800	16 100	0.360
VEB 85	85	120	18	23	11.11	3 050	2 790	2 880	2 640	22 900	14 900	0.500
VEB 90	90	125	18	24	11.11	3 110	2 930	2 940	2 770	21 800	14 200	0.540
VEB 95	95	130	18	25	11.11	3 170	3 070	2 990	2 900	20 700	13 500	0.560
VEB 100	100	140	20	24	12.70	3 970	3 810	3 760	3 610	19 300	12 500	0.770
VEB 110	110	150	20	26	12.70	4 130	4 170	3 900	3 950	17 500	11 400	0.830
VEB 120	120	165	22	24	14.28	4 860	4 860	4 600	4 600	15 900	10 300	1.100

Größere Abmessungen auf Anfrage.

Referenzdrehzahlen Vh für Schrägkugellager mit  $\alpha = 15^\circ$  und Federvorspannung  
Berechnung der Drehzahlgrenzen von Lagersätzen siehe Seite 27.

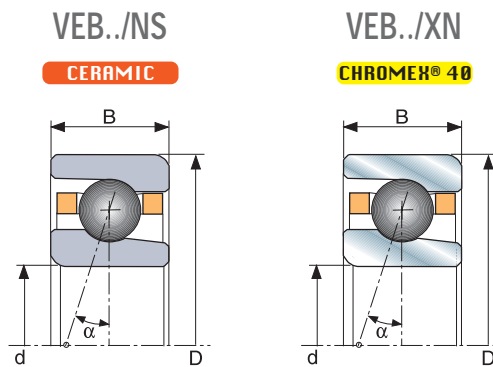

ISO 19

VEB

SNFA						CERAMIC Öl    Fett		CHROMEX®40 Öl    Fett					
	d	D	B	z	Ø	α = 15°		α = 25°		Vh	Vh	Vh	Vh
						C33	Co	C33	Co	(ABEC 9)	(ABEC 9)	(ABEC 9)	(ABEC 9)
VEB 8/..	8	19	6	9	3.17	178	53			221 000	144 000	244 000	158 000
VEB 10/..	10	22	6	11	3.17	210	68	198	65	186 000	121 000	206 000	133 000
VEB 12/..	12	24	6	12	3.17	220	77	210	73	165 000	107 000	182 000	118 000
VEB 15/..	15	28	7	12	3.97	330	119	310	113	138 000	89 700	153 000	99 000
VEB 17/..	17	30	7	13	3.97	340	132	330	125	126 000	81 900	140 000	90 400
VEB 20/..	20	37	9	14	4.76	500	210	480	195	104 000	67 200	115 000	74 200
VEB 25/..	25	42	9	16	4.76	540	240	510	230	88 000	57 000	97 500	63 000
VEB 30/..	30	47	9	18	4.76	580	280	540	270	76 000	49 400	84 500	54 600
VEB 35/..	35	55	10	19	5.55	790	400	750	380	65 000	42 200	72 000	46 600
VEB 40/..	40	62	12	19	6.35	1 000	530	950	500	57 000	37 000	63 000	41 000
VEB 45/..	45	68	12	21	6.35	1 050	590	1 000	560	51 000	33 300	57 000	36 800
VEB 50/..	50	72	12	21	7.14	1 310	740	1 240	700	48 000	30 800	52 500	34 000
VEB 55/..	55	80	13	21	7.94	1 590	920	1 500	870	43 000	27 700	47 500	30 600
VEB 60/..	60	85	13	23	7.94	1 670	1 020	1 580	960	40 000	25 700	44 000	28 400
VEB 65/..	65	90	13	24	7.94	1 690	1 070	1 600	1 010	37 000	24 000	41 000	26 500
VEB 70/..	70	100	16	22	9.52	2 260	1 400	2 130	1 320	33 500	21 800	37 000	24 000
VEB 75/..	75	105	16	23	9.52	2 300	1 470	2 170	1 390	31 500	20 500	35 000	22 600
VEB 80/..	80	110	16	24	9.52	2 340	1 550	2 210	1 460	30 000	19 300	33 000	21 400
VEB 85/..	85	120	18	23	11.11	3 050	1 990	2 880	1 890	27 500	17 900	30 500	19 700
VEB 90/..	90	125	18	24	11.11	3 110	2 100	2 940	1 980	26 500	17 000	29 000	18 800
VEB 95/..	95	130	18	25	11.11	3 170	2 200	2 990	2 080	25 000	16 100	27 500	17 800
VEB 100/..	100	140	20	24	12.70	3 970	2 730	3 760	2 580	23 500	15 000	26 000	16 600
VEB 110/..	110	150	20	26	12.70	4 130	2 990	3 900	2 830	21 000	13 700	23 500	15 100
VEB 120/..	120	165	22	24	14.28	4 860	3 480	4 600	3 300	19 000	12 400	21 500	13 700

Größere Abmessungen auf Anfrage.

Da verbindliche Standards für die Berechnung von dynamischen Tragzahlen C33 für die Paarungen Keramik-Kugeln/100Cr6 bzw. Keramik-Kugeln /Chromex®40 fehlen, verwendet SNFA die gleichen dynamischen Tragzahlen C33 wie für die Paarung Stahl-Kugeln/100Cr6.

Die Anpassung der berechneten Lebensdauerwerte erfolgt mit Faktoren, die auf Erfahrungswerten basieren (siehe Seite 20).



## Vospannungs- und Steifigkeitswerte (fest vorgespannt) Druckwinkel = 15°

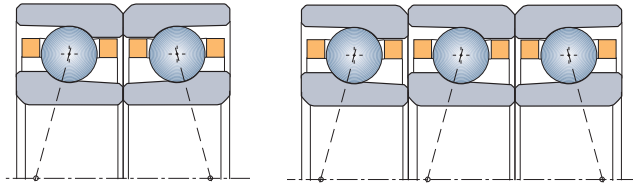

ISO 19

VEB

SNFA	Leichte Vorspannung L			Mittlere Vorspannung M			Starke Vorspannung F		
	Pr	Ra		Pr	Ra		Pr	Ra	
		Paar	Dreier		Paar	Dreier		Paar	Dreier
VEB 8	0.9	0.8	1.2	2.7	1.3	1.8	5.5	1.8	2.5
VEB 10	1.1	1.0	1.4	3.2	1.5	2.2	6.5	2.1	3.1
VEB 12	1.1	1.0	1.5	3.4	1.7	2.4	6.8	2.3	3.3
VEB 15	1.7	1.3	1.9	5.1	2.0	2.9	10.2	2.8	4.0
VEB 17	1.8	1.4	2.0	5.4	2.2	3.1	10.8	3.0	4.3
VEB 20	2.6	1.7	2.5	7.9	2.8	4.0	15.7	3.8	5.4
VEB 25	2.8	1.9	2.8	8.5	3.1	4.4	17.0	4.2	6.0
VEB 30	3.0	2.1	3.1	9.0	3.4	4.8	18.0	4.6	6.6
VEB 35	4.1	2.6	3.8	12.5	4.1	5.9	25.0	5.5	7.9
VEB 40	5.2	2.9	4.3	15.7	4.6	6.6	31.5	6.3	9.0
VEB 45	5.5	3.2	4.6	16.6	5.0	7.2	33.1	6.8	9.7
VEB 50	6.9	3.6	5.2	21.0	5.5	8.0	41.0	7.6	10.8
VEB 55	8.3	3.9	5.7	25.0	6.1	8.8	50.0	8.3	11.9
VEB 60	8.7	4.2	6.2	26.2	6.6	9.5	52.3	8.9	12.8
VEB 65	8.9	4.4	6.4	26.6	6.8	9.8	53.2	9.2	13.2
VEB 70	12.0	4.8	7.1	36.0	7.5	10.8	71.0	10.2	14.6
VEB 75	12.0	5.0	7.3	36.1	7.7	11.2	72.2	10.5	15.1
VEB 80	12.3	5.2	7.5	37.0	8.0	11.6	74.0	10.8	15.6
VEB 85	16.0	5.8	8.4	47.9	8.9	12.9	95.7	12.1	17.4
VEB 90	16.3	6.0	8.7	48.8	9.2	13.3	97.7	12.5	17.9
VEB 95	16.6	6.2	9.0	50.0	9.5	13.8	99.5	12.9	18.5
VEB 100	20.8	6.8	9.8	62.4	10.5	15.1	125.0	14.1	20.3
VEB 110	22.0	7.2	10.6	65.0	11.1	16.1	130.0	15.1	21.6
VEB 120	25.0	7.5	10.9	76.0	11.6	16.7	153.0	15.7	22.5

**Vospannungs- und Steifigkeitswerte  
(fest vorgespannt)  
Druckwinkel = 25°**

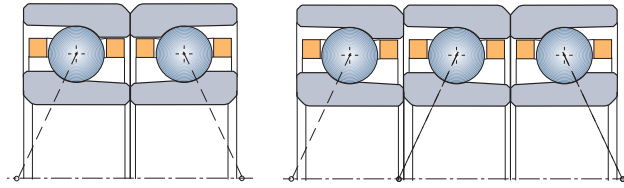

ISO 19

VEB

SNFA	Leichte Vorspannung L			Mittlere Vorspannung M			Starke Vorspannung F		
	Pr	Ra		Pr	Ra		Pr	Ra	
		Paar	Dreier		Paar	Dreier		Paar	Dreier
VEB 8									
VEB 10	1.7	2.4	3.5	5.0	3.5	5.2	10.0	4.6	6.7
VEB 12	1.8	2.6	3.8	5.5	3.9	5.7	11.0	5.1	7.4
VEB 15	2.8	3.2	4.7	8.4	4.8	7.0	17.0	6.3	9.2
VEB 17	2.9	3.4	5.0	8.7	5.1	7.5	17.5	6.7	9.8
VEB 20	4.2	4.3	6.3	13.0	6.5	9.5	25.0	8.4	12.2
VEB 25	4.5	4.8	7.1	14.0	7.3	10.7	27.0	9.4	13.7
VEB 30	4.8	5.4	7.8	14.5	8.0	11.6	29.0	10.4	15.1
VEB 35	6.6	6.5	9.5	20.0	9.6	14.1	40.0	12.5	18.2
VEB 40	8.4	7.3	10.8	25.0	10.9	15.9	50.5	14.2	20.6
VEB 45	8.8	8.0	11.7	26.5	11.8	17.3	52.9	15.4	22.4
VEB 50	11.0	8.9	13.1	33.0	13.2	19.3	66.0	17.2	25.0
VEB 55	13.3	9.8	14.4	40.0	14.6	21.3	80.0	18.9	27.6
VEB 60	13.9	10.6	15.6	41.8	15.7	23.0	83.6	20.4	29.7
VEB 65	14.2	11.0	16.1	42.5	16.3	23.8	85.0	21.1	30.7
VEB 70	19.0	12.1	17.8	57.0	17.9	26.2	113.0	23.3	33.9
VEB 75	19.2	12.5	18.4	57.7	18.6	27.2	115.0	24.1	35.1
VEB 80	19.5	13.0	19.0	59.0	19.2	28.1	117.0	24.9	36.3
VEB 85	25.5	14.5	21.3	76.5	21.5	31.4	153.0	27.8	40.5
VEB 90	26.0	15.0	22.0	78.0	22.2	32.5	156.0	28.8	41.9
VEB 95	26.5	15.5	22.8	79.5	23.0	33.6	159.0	29.7	43.3
VEB 100	33.2	17.0	25.0	99.6	25.2	36.8	199.0	32.6	47.5
VEB 110	34.0	18.1	26.5	103.0	26.8	39.2	207.0	34.8	50.7
VEB 120	41.0	19.0	27.9	122.0	28.0	40.9	244.0	36.2	52.8





# HB

## ISO 19

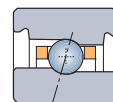

HB..

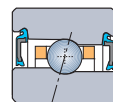

HB../S

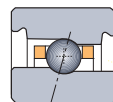

HB../NS

CERAMIC

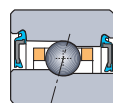

HB../S/NS

CERAMIC

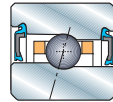

HB../XN/S

CHROME<sup>®</sup> 40

HB..

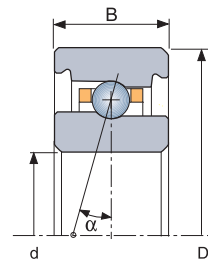

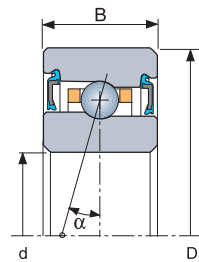

HB../S



ISO 19

HB

SNFA	d	D	B	z	Ø	 $\alpha = 15^\circ$			 $\alpha = 25^\circ$			Öl	Fett	Masse
						C33	CE	Co	C33	CE	Co	Vh (ABEC 9)	Vh (ABEC 9)	
HB 30	30	47	9	21	3.969	480	640	370	450	600	350	60 000	39 000	0.050
HB 35	35	55	10	25	3.969	520	690	450	500	665	420	51 000	33 100	0.080
HB 40	40	62	12	28	3.969	550	730	510	520	690	480	45 000	29 300	0.120
HB 45	45	68	12	27	4.762	760	1 010	700	720	960	660	40 500	26 300	0.140
HB 50	50	72	12	29	4.762	780	1 040	760	740	980	710	37 500	24 400	0.140
HB 55	55	80	13	28	5.556	1 020	1 360	990	960	1 280	930	34 000	22 100	0.190
HB 60	60	85	13	30	5.556	1 050	1 400	1 070	990	1 320	1 010	32 000	20 800	0.200
HB 65	65	90	13	32	5.556	1 080	1 440	1 140	1 020	1 360	1 080	30 000	19 500	0.220
HB 70	70	100	16	32	6.35	1 390	1 850	1 490	1 310	1 740	1 410	26 500	17 200	0.360
HB 75	75	105	16	34	6.35	1 430	1 900	1 590	1 350	1 800	1 500	25 000	16 300	0.380
HB 80	80	110	16	34	6.747	1 600	2 130	1 800	1 500	2 000	1 690	23 500	15 300	0.390
HB 85	85	120	18	37	6.747	1 660	2 210	1 970	1 560	2 070	1 860	22 000	14 300	0.580
HB 90	90	125	18	36	7.144	1 810	2 410	2 150	1 700	2 260	2 020	20 500	13 300	0.600
HB 95	95	130	18	38	7.144	1 860	2 470	2 270	1 750	2 330	2 150	19 800	12 900	0.620
HB 100	100	140	20	37	7.938	2 230	2 970	2 720	2 100	2 790	2 570	18 500	12 000	0.850
HB 110	110	150	20	37	8.731	2 650	3 520	3 290	2 500	3 320	3 100	17 000	11 000	0.900
HB 120	120	165	22	41	8.731	2 780	3 700	3 670	2 610	3 470	3 470	15 400	10 000	1.270

Größere Abmessungen auf Anfrage.

Referenzdrehzahlen Vh für Schrägkugellager mit  $\alpha = 15^\circ$  und Federvorspannung  
Berechnung der Drehzahlgrenzen von Lagersätzen siehe Seite 27.

**CE:** Erweiterte dynamische Tragzahl, ergibt sich durch die Verbesserungen der Materialien und Produktionsprozesse.  
Diese Werte werden von SNFA nicht verwendet und dienen hauptsächlich zur Information sowie zu Vergleichszwecken.

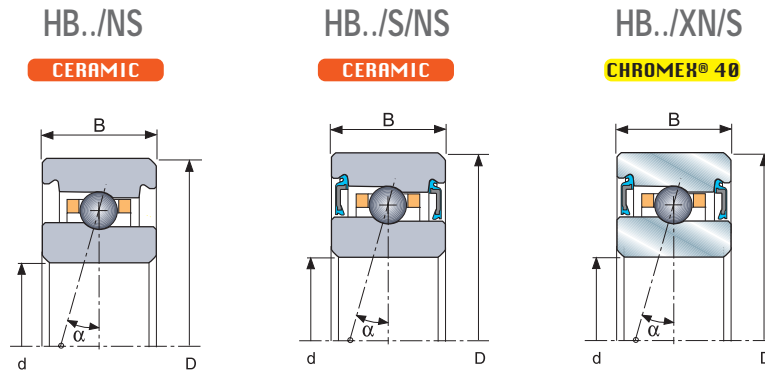

ISO 19

HB

SNFA	d	D	B	z	Ø	CERAMIC			CHROMEK® 40						
						α = 15°			α = 25°			Öl	Fett	Öl	Fett
						C33	CE	Co	C33	CE	Co	Vh (ABEC 9)	Vh (ABEC 9)	Vh (ABEC 9)	Vh (ABEC 9)
HB 30/..	30	47	9	21	3.969	480	640	265	450	600	250	72 000	46 800	80 500	51 700
HB 35/..	35	55	10	25	3.969	520	690	320	500	665	300	61 000	39 800	68 500	43 900
HB 40/..	40	62	12	28	3.969	550	730	360	520	690	340	54 000	35 100	60 500	38 800
HB 45/..	45	68	12	27	4.762	760	1 010	500	720	960	470	49 000	31 600	54 500	34 900
HB 50/..	50	72	12	29	4.762	780	1 040	540	740	980	510	45 000	29 300	50 500	32 300
HB 55/..	55	80	13	28	5.556	1 020	1 360	710	960	1 280	670	41 000	26 600	45 500	29 300
HB 60/..	60	85	13	30	5.556	1 050	1 400	760	990	1 320	720	38 500	25 000	43 000	27 600
HB 65/..	65	90	13	32	5.556	1 080	1 440	820	1 020	1 360	770	36 000	23 400	40 500	25 800
HB 70/..	70	100	16	32	6.35	1 390	1 850	1 060	1 310	1 740	1 010	32 000	20 700	35 500	22 800
HB 75/..	75	105	16	34	6.35	1 430	1 900	1 140	1 350	1 800	1 070	30 000	19 500	33 500	21 500
HB 80/..	80	110	16	34	6.747	1 600	2 130	1 280	1 500	2 000	1 210	28 500	18 300	31 500	20 200
HB 85/..	85	120	18	37	6.747	1 660	2 210	1 410	1 560	2 070	1 330	26 500	17 200	29 500	18 900
HB 90/..	90	125	18	36	7.144	1 810	2 410	1 540	1 700	2 260	1 450	24 500	16 000	27 500	17 700
HB 95/..	95	130	18	38	7.144	1 860	2 470	1 630	1 750	2 330	1 530	24 000	15 400	26 500	17 000
HB 100/..	100	140	20	37	7.938	2 230	2 970	1 950	2 100	2 790	1 840	22 500	14 400	25 000	15 900
HB 110/..	110	150	20	37	8.731	2 650	3 520	2 350	2 500	3 320	2 220	20 500	13 300	23 000	14 600
HB 120/..	120	165	22	41	8.731	2 780	3 700	2 630	2 610	3 470	2 480	18 500	12 000	20 500	13 300

Größere Abmessungen auf Anfrage.

Referenzdrehzahlen Vh für Schrägkugellager mit α = 15° und Federvorspannung  
Berechnung der Drehzahlgrenzen von Lagersätzen siehe Seite 27.

**CE:** Erweiterte dynamische Tragzahl, ergibt sich durch die Verbesserungen der Materialien und Produktionsprozesse.  
Diese Werte werden von SNFA nicht verwendet und dienen hauptsächlich zur Information sowie zu Vergleichszwecken.

Da verbindliche Standards für die Berechnung von dynamischen Tragzahlen C33 für die Paarungen Keramikugeln/100Cr6 bzw. Keramikugeln /Chromex®40 fehlen, verwendet SNFA die gleichen dynamischen Tragzahlen C33 wie für die Paarung Stahlkugeln/100Cr6.

Die Anpassung der berechneten Lebensdauerwerte erfolgt mit Faktoren, die auf Erfahrungswerten basieren (siehe Seite 20).





## Vospannungs- und Steifigkeitswerte (fest vorgespannt) Druckwinkel = 15°

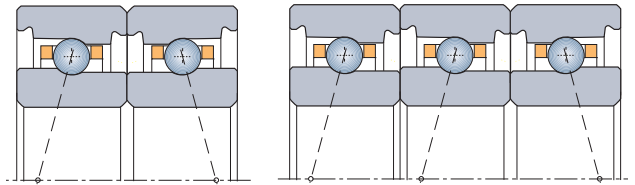

ISO 19

HB

SNFA	Leichte Vorspannung L			Mittlere Vorspannung M			Starke Vorspannung F		
	Pr	Ra		Pr	Ra		Pr	Ra	
		Paar	Dreier		Paar	Dreier		Paar	Dreier
HB 30	1.60	1.90	2.70	3.10	2.50	3.60	9.40	4.00	5.70
HB 35	1.70	2.20	3.10	3.40	2.80	4.10	10.20	4.50	6.50
HB 40	1.80	2.40	3.40	3.60	3.10	4.50	10.70	4.90	7.10
HB 45	2.40	2.70	3.90	4.90	3.50	5.20	14.80	5.70	8.20
HB 50	2.60	2.90	4.20	5.10	3.80	5.50	15.30	6.0	8.60
HB 55	3.30	3.20	4.70	6.60	4.20	6.10	20.00	6.70	9.70
HB 60	3.40	3.40	5.00	6.80	4.40	6.50	20.50	7.10	10.20
HB 65	3.50	3.60	5.20	7.00	4.70	6.80	21.00	7.40	10.7
HB 70	4.50	4.10	5.90	9.00	5.30	7.70	27.00	8.40	12.10
HB 75	4.60	4.30	6.20	9.30	5.60	8.10	28.00	8.80	12.70
HB 80	5.20	4.50	6.60	10.40	5.90	8.60	31.00	9.30	13.40
HB 85	5.40	4.80	7.10	10.80	6.30	9.20	32.00	9.90	14.20
HB 90	5.90	5.00	7.30	11.70	6.50	9.40	35.00	10.20	14.70
HB 95	6.00	5.20	7.60	12.00	6.80	9.80	36.00	10.70	15.30
HB 100	7.20	5.60	8.20	14.40	7.30	10.60	43.00	11.5	16.5
HB 110	8.60	6.10	9.00	17.20	8.00	11.60	51.50	12.60	18.10
HB 120	9.00	6.70	9.70	18.00	8.70	12.60	54.00	13.60	19.60

**Vospannungs- und Steifigkeitswerte**  
 (fest vorgespannt)  
 Druckwinkel = 25°

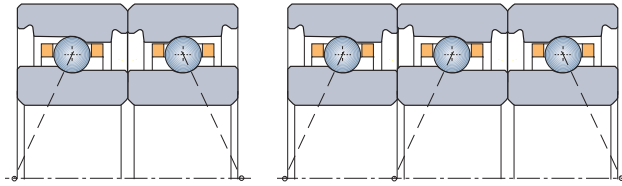

ISO 19

HB

SNFA	Leichte Vorspannung L			Mittlere Vorspannung M			Starke Vorspannung F		
	Pr	Ra		Pr	Ra		Pr	Ra	
		Paar	Dreier		Paar	Dreier		Paar	Dreier
HB 30	2.50	4.70	6.90	5.00	6.00	8.80	15.00	9.00	13.20
HB 35	2.70	5.40	7.90	5.40	6.90	10.10	16.50	10.40	15.20
HB 40	2.90	6.00	8.80	5.70	7.60	11.10	17.00	11.30	16.50
HB 45	3.90	6.80	10.00	7.90	8.80	12.80	23.50	13.10	19.10
HB 50	4.00	7.20	10.60	8.10	9.30	13.50	24.50	13.90	20.20
HB 55	5.30	8.20	12.00	10.60	10.40	15.20	31.50	15.50	22.60
HB 60	5.40	8.60	12.60	10.90	11.00	16.10	32.50	16.40	23.90
HB 65	5.60	9.10	13.30	11.20	11.60	16.90	33.50	17.30	25.20
HB 70	7.20	10.30	15.10	14.40	13.10	19.20	43.00	19.60	28.60
HB 75	7.40	10.80	15.90	14.80	13.80	20.20	44.50	20.60	30.10
HB 80	8.20	11.40	16.80	16.50	14.60	21.40	49.50	21.80	31.80
HB 85	8.60	12.30	18.00	17.10	15.60	22.90	51.50	23.30	34.00
HB 90	9.30	12.60	18.50	18.70	16.10	23.60	56.00	24.00	35.00
HB 95	9.60	13.20	19.40	19.20	16.80	24.70	57.50	25.10	36.60
HB 100	11.50	14.30	20.90	23.00	18.20	26.60	69.00	27.10	39.50
HB 110	13.70	15.60	22.90	27.40	19.90	29.10	82.00	29.60	43.20
HB 120	14.30	16.90	24.90	28.70	21.60	31.70	86.00	32.10	46.90

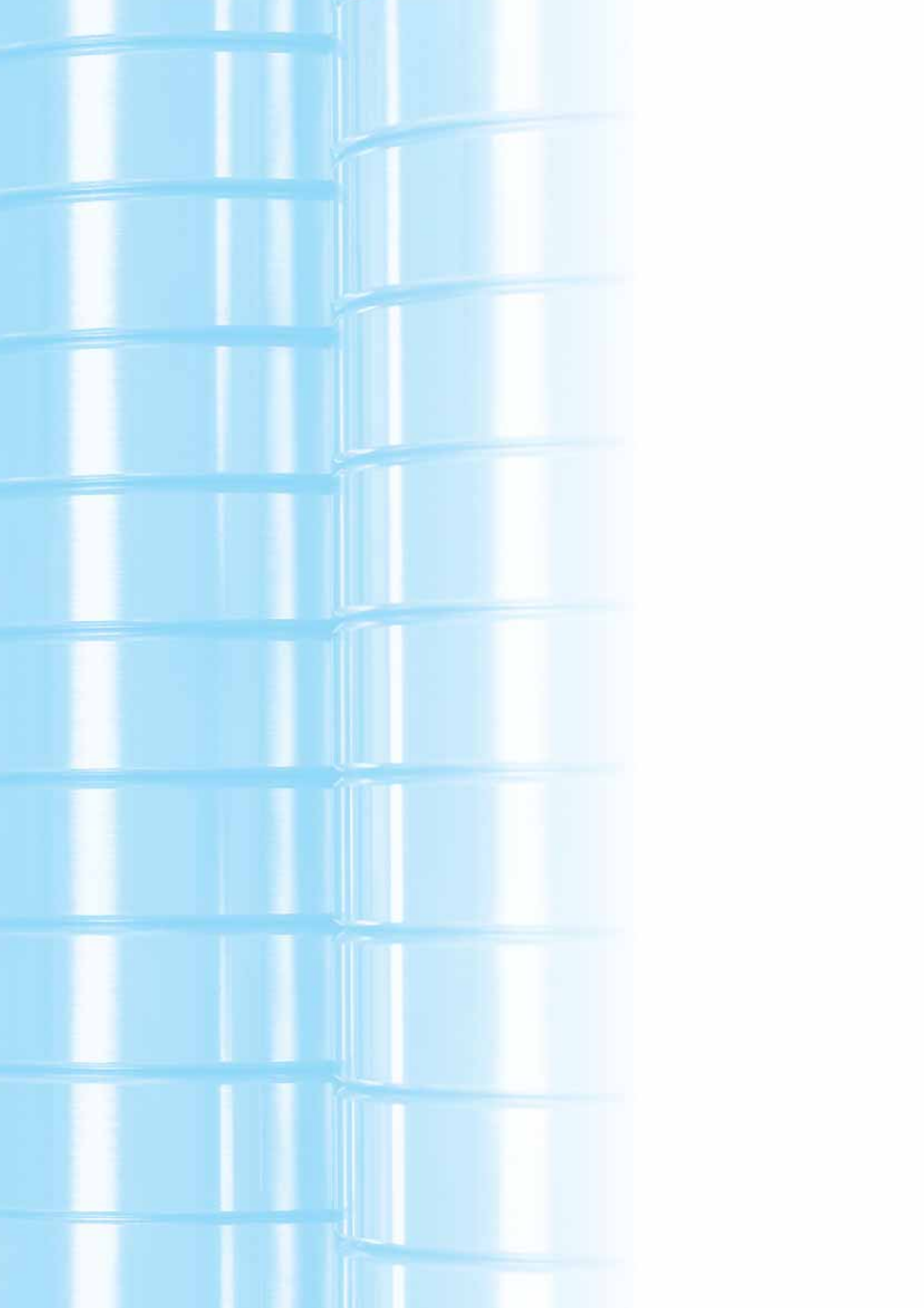

# EX

ISO 10

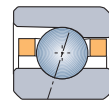

EX



ISO 10

EX

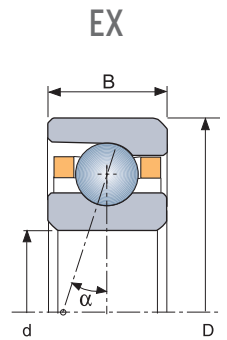

SNFA	d	D	B	z	Ø	$\alpha = 15^\circ$		$\alpha = 25^\circ$		Öl	Fett	Masse
						C33	Co	C33	Co	Vh (ABEC 9)	Vh (ABEC 9)	
EX 6	6	17	6	8	3.17	160	61	155	59	178 000	116 000	0.006
EX 7	7	19	6	8	3.57	198	77	191	75	157 000	102 000	0.008
EX 8	8	22	7	8	3.97	311	150	300	145	134 000	87 100	0.011
EX 9	9	24	7	9	3.97	341	176	328	169	122 000	79 300	0.014
EX 10	10	26	8	11	3.97	391	223	374	214	112 000	72 800	0.018
EX 12	12	28	8	10	4.76	507	280	488	270	101 000	65 700	0.019
EX 15	15	32	9	12	4.76	576	360	550	350	85 000	55 300	0.028
EX 17	17	35	10	12	5.55	761	480	728	460	76 500	49 700	0.037
EX 20	20	42	12	12	6.35	967	640	924	610	64 500	42 000	0.064
EX 25	25	47	12	13	7.14	1 261	890	1 203	850	55 500	36 100	0.075
EX 30	30	55	13	13	7.94	1 520	1 110	1 450	1 060	47 000	30 600	0.108
EX 35	35	62	14	15	7.94	1 950	1 730	1 846	1 650	35 000	22 800	0.135
EX 40	40	68	15	16	7.94	2 015	1 900	1 885	1 810	31 000	20 200	0.190
EX 45	45	75	16	15	9.52	2 770	2 510	2 630	2 400	28 000	18 200	0.228
EX 50	50	80	16	16	9.52	2 860	2 730	2 700	2 600	25 500	16 600	0.246
EX 55	55	90	18	16	11.11	3 720	3 680	3 520	3 510	23 000	15 000	0.360
EX 60	60	95	18	17	11.11	3 835	3 980	3 630	3 780	21 000	13 700	0.384
EX 65	65	100	18	18	11.11	3 940	4 270	3 740	4 060	20 000	13 000	0.408
EX 70	70	110	20	18	12.70	5 160	5 500	4 880	5 200	18 300	11 900	0.580
EX 75	75	115	20	19	12.70	5 290	5 900	5 000	5 600	17 200	11 200	0.613
EX 80	80	125	22	18	14.28	6 360	7 000	6 010	6 700	15 600	10 100	0.826
EX 85	85	130	22	19	14.28	6 540	7 500	6 180	7 100	15 000	9 800	0.868
EX 90	90	140	24	21	14.28	6 790	8 400	6 400	7 900	13 900	9 000	1.145
EX 95	95	145	24	20	15.87	8 020	9 700	7 590	9 200	13 300	8 600	1.160
EX 100	100	150	24	21	15.87	8 255	10 300	7 760	9 800	12 800	8 300	1.211
EX 105	105	160	26	20	17.46	9 700	11 800	9 150	11 200	11 700	7 600	1.535
EX 110	110	170	28	20	19.05	11 400	13 900	10 780	13 200	11 100	7 200	1.942
EX 120	120	180	28	21	19.05	11 620	14 800	10 970	14 100	10 000	6 500	2.055
EX 130	130	200	33	20	22.22	15 020	19 000	14 180	18 000	9 400	6 100	3.080
EX 140	140	210	33	21	22.22	15 340	20 200	14 480	19 100	8 300	5 400	3.280
EX 150	150	225	35	21	23.81	17 370	23 100	16 390	22 000	7 800	5 100	4.030
EX 160	160	240	38	21	25.40	19 500	26 300	18 400	25 000	7 200	4 700	5.000
EX 170	170	260	42	21	26.99	21 190	29 800	19 990	28 300	6 700	4 350	6.650
EX 180	180	280	46	22	28.57	23 630	35 000	22 290	33 300	6 100	3 950	9.000
EX 190	190	290	46	23	28.57	24 120	36 900	22 750	35 100	5 800	3 750	9.460
EX 200	200	310	51	20	34.92	30 290	46 600	28 600	44 400	5 300	3 450	12.200
EX 220	220	340	56	20	38.10	34 140	55 600	32 240	52 900	4 700	3 050	15.600
EX 240	240	360	56	22	38.10	35 930	62 000	33 930	58 900	4 300	2 800	17.250

Größere Abmessungen auf Anfrage.

Referenzdrehzahlen Vh für Schrägkugellager mit  $\alpha = 15^\circ$  und Federvorspannung  
Berechnung der Drehzahlgrenzen von Lagersätzen siehe Seite 27.



# Vospannungs- und Steifigkeitswerte (fest vorgespannt) Druckwinkel = 15°

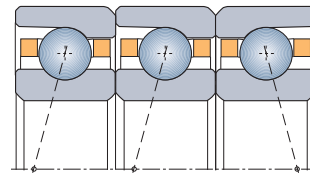
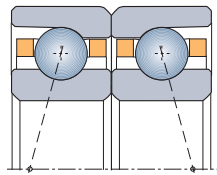

ISO 10



SNFA	Leichte Vorspannung L			Mittlere Vorspannung M			Starke Vorspannung F		
	Pr	Ra		Pr	Ra		Pr	Ra	
		Paar	Dreier		Paar	Dreier		Paar	Dreier
EX 6	0.8	0.8	1.1	2.5	1.2	1.7	5.0	1.5	2.1
EX 7	1.0	0.9	1.3	3.0	1.3	1.9	6.0	1.6	2.4
EX 8	1.6	1.1	1.6	5.0	1.6	2.3	10.0	2.0	2.9
EX 9	1.8	1.2	1.7	5.5	1.7	2.4	11.0	2.1	3.0
EX 10	2.0	1.5	2.1	6.0	2.1	3.1	12.0	2.7	3.9
EX 12	2.7	1.5	2.2	8.0	2.2	3.2	16.0	2.8	4.0
EX 15	3.0	1.9	2.7	9.0	2.7	4.0	18.0	3.4	5.0
EX 17	4.0	2.2	3.2	12.0	3.2	4.6	24.0	4.0	5.8
EX 20	5.0	2.3	3.3	15.0	3.3	4.8	30.0	4.2	6.0
EX 25	6.5	3.0	4.3	19.5	4.2	6.2	39.0	5.3	7.8
EX 30	8.0	3.3	4.8	24.0	4.7	6.9	48.0	6.0	8.7
EX 35	10.0	3.8	5.8	30.5	5.6	8.3	61.0	7.1	10.4
EX 40	10.5	4.1	6.1	32.0	5.9	8.7	63.5	7.4	11.0
EX 45	14.0	4.6	6.8	42.5	6.7	9.8	85.0	8.4	12.3
EX 50	14.5	4.8	7.3	44.0	6.9	10.5	88.0	8.8	13.2
EX 55	19.5	5.6	8.3	58.5	8.2	12.0	117.0	10.2	15.1
EX 60	20.0	5.9	8.8	60.5	8.6	12.6	120.5	10.8	15.9
EX 65	21.0	6.3	9.2	62.0	9.1	13.3	124.0	11.4	16.8
EX 70	27.0	7.1	10.4	80.0	10.2	15.0	160.0	12.8	18.9
EX 75	27.5	7.4	10.9	82.0	10.7	15.7	164.0	13.5	19.8
EX 80	33.0	7.9	11.7	98.5	11.5	16.9	197.0	14.4	21.2
EX 85	34.0	8.3	12.2	101.0	12.0	17.7	202.0	15.1	22.2
EX 90	36.0	9.0	13.3	107.0	13.0	19.1	214.0	16.8	24.1
EX 95	42.0	9.6	14.1	127.0	13.8	20.3	253.0	17.4	25.6
EX 100	43.0	10.0	14.7	130.0	14.4	21.1	259.0	18.1	26.6
EX 105	50.0	10.5	15.7	150.0	15.1	22.2	300.0	19.0	28.0
EX 110	59.0	11.4	16.7	177.0	16.4	23.9	354.0	20.7	30.4
EX 120	60.0	11.8	17.4	180.0	17.1	25.1	360.0	21.5	31.6
EX 130	78.0	13.2	19.4	234.0	19.0	27.9	468.0	23.9	35.2
EX 140	80.0	13.7	20.2	240.0	19.8	29.1	480.0	24.9	36.6
EX 150	90.0	14.6	21.5	270.0	21.0	30.9	540.0	26.5	39.0
EX 160	102.0	15.5	22.9	306.0	22.4	33.0	612.0	28.2	41.5
EX 170	110.0	16.3	23.9	330.0	24.5	34.5	660.0	29.6	43.5
EX 180	123.0	17.7	26.1	369.0	25.6	37.6	738.0	32.2	47.4
EX 190	126.0	18.4	27.1	378.0	26.6	39.1	756.0	33.5	49.2
EX 200	160.0	19.4	28.6	480.0	28.0	41.2	960.0	35.3	51.9
EX 220	180.0	20.8	30.6	540.0	30.0	44.1	1 080.0	37.8	55.6
EX 240	190.0	22.6	33.2	570.0	32.5	47.9	1 140.0	41.0	60.3





ISO 10

EX

## Vospannungs- und Steifigkeitswerte (fest vorgespannt) Druckwinkel = 25°

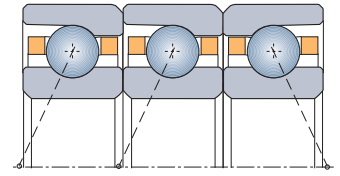
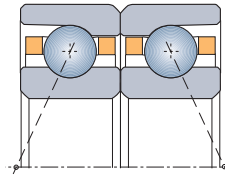

SNFA	Leichte Vorspannung L			Mittlere Vorspannung M			Starke Vorspannung F		
	Pr	Ra		Pr	Ra		Pr	Ra	
		Paar	Dreier		Paar	Dreier		Paar	Dreier
EX 6	1.5	2.2	3.3	4.0	3.2	4.6	8.0	4.0	5.8
EX 7	1.7	2.5	3.6	5.0	3.5	5.1	10.0	4.5	6.5
EX 8	2.5	2.9	4.2	8.0	4.3	6.2	16.0	5.4	7.9
EX 9	3.0	3.0	4.5	9.0	4.4	6.5	18.0	5.5	8.2
EX 10	3.3	3.9	5.7	10.0	5.7	8.3	20.0	7.1	10.5
EX 12	4.5	4.0	5.9	13.0	5.8	8.4	26.0	7.2	10.6
EX 15	5.0	5.0	7.4	15.0	7.3	10.7	30.0	9.1	13.5
EX 17	6.5	5.8	8.5	19.5	8.4	12.3	39.0	10.6	15.5
EX 20	8.0	6.0	8.8	24.0	8.7	12.7	48.0	11.0	16.0
EX 25	10.5	7.9	11.5	32.0	11.4	16.7	64.0	14.3	21.0
EX 30	13.0	8.7	12.8	38.5	12.5	18.4	77.0	15.8	23.2
EX 35	16.5	10.4	15.2	49.0	14.8	22.0	98.0	18.6	27.7
EX 40	17.0	10.9	16.1	51.0	15.8	23.3	102.0	19.9	29.3
EX 45	23.0	12.3	18.1	69.0	17.8	26.2	137.0	22.4	33.0
EX 50	23.5	13.1	19.1	70.5	18.8	27.7	141.0	23.7	34.9
EX 55	31.5	14.9	22.1	94.0	21.6	31.8	188.0	27.2	40.1
EX 60	32.5	15.9	23.4	97.0	23.0	33.8	194.0	28.9	42.6
EX 65	33.0	16.7	24.6	99.0	24.1	35.5	199.0	30.4	44.7
EX 70	42.5	18.9	27.8	128.0	27.3	40.1	255.0	34.3	50.5
EX 75	43.5	19.7	29.0	131.0	28.5	41.9	262.0	35.9	52.8
EX 80	52.5	21.1	30.1	157.5	30.4	44.7	315.0	38.3	56.3
EX 85	54.0	22.0	32.3	162.0	31.7	46.6	323.0	40.0	58.7
EX 90	57.0	23.8	35.3	171.0	34.4	50.6	341.0	43.1	63.8
EX 95	67.0	25.2	37.2	202.0	36.5	53.7	404.0	45.7	67.7
EX 100	69.0	26.4	38.8	207.0	38.1	56.0	415.0	48.0	70.6
EX 105	80.0	27.7	40.8	240.0	40.0	58.0	480.0	50.4	74.1
EX 110	95.0	30.2	44.4	285.0	43.6	64.1	570.0	54.9	80.8
EX 120	97.0	31.4	46.2	291.0	45.3	66.7	582.0	57.1	84.0
EX 130	125.0	34.9	51.3	375.0	50.3	74.0	750.0	63.4	93.2
EX 140	128.0	36.3	53.4	384.0	52.4	77.0	768.0	66.0	97.0
EX 150	144.0	38.6	56.8	432.0	55.7	82.0	864.0	70.2	103.3
EX 160	162.0	41.0	60.4	486.0	59.2	87.1	972.0	74.6	109.7
EX 170	176.0	43.1	63.3	528.0	62.1	91.4	1 056.0	78.3	115.1
EX 180	197.0	47.0	69.1	591.0	67.8	99.7	1 182.0	85.4	125.6
EX 190	200.0	48.7	71.8	600.0	70.2	103.2	1 200.0	88.4	130.1
EX 200	250.0	51.0	75.1	750.0	73.6	108.3	1 500.0	92.8	136.5
EX 220	280.0	54.6	80.3	840.0	78.7	115.8	1 680.0	99.2	145.9
EX 240	300.0	59.5	87.6	900.0	85.9	126.3	1 800.0	108.2	159.1

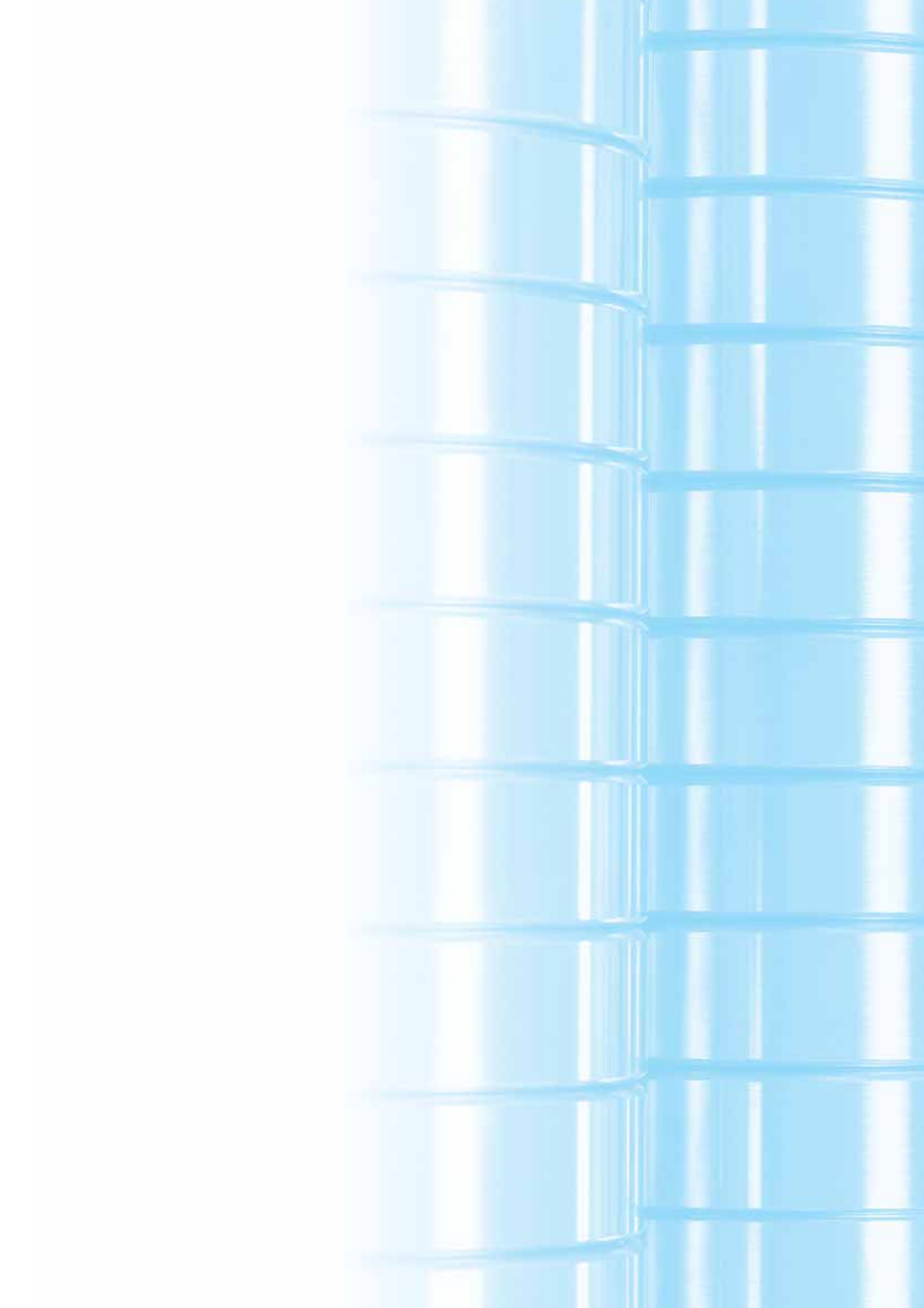

## Spindellager für Höchstdrehzahlen Serie VEX



Die Lagerreihen VEX (ISO 10) wurden speziell für den Einsatz bei hohen und extrem hohen Drehzahlen - unabhängig von der Schmierungsart - entwickelt.

Bei der Entwicklung und Produktion dieser Baureihen wurden verschiedene, für die Hochgeschwindigkeitsanwendungen ausschlaggebende Einflüsse analysiert, insbesondere Dynamik- und Erwärmungseffekte einschließlich Schmierungsprobleme, ohne dabei die Belastbarkeit und Steifigkeit zu vernachlässigen.

Die in der Tabelle angegebenen Drehzahlwerte gelten bei optimalen Betriebsbedingungen.

Im Falle einer festen Vorspannung reduzieren sich die jeweiligen Werte durch thermisch bedingten Vorspannungsanstieg, wie z.B. durch die vom Elektromotor (Wirbelstromverluste) verursachte Erwärmung.

Maximale Drehzahlen werden durch den Einsatz von VEB- und HB-Lagern in der Ausführung mit Schmierlöcher im Außenring und Keramikugeln erreicht.

Um eine optimale Nutzung der Lager zu erreichen, sind folgende Parameter notwendig: minimale Öl-Luft-Schmierung, jedes Lager separat, konstante Vorspannung, genaue Ausführung der Anschlußteile sowie ein hoher dynamischer Auswuchtgrad.

# VEX

ISO 10

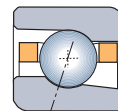

VEX..

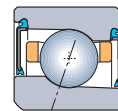

VEX../S

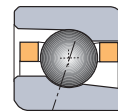

VEX../NS

CERAMIC

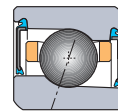

VEX../S/NS

CERAMIC

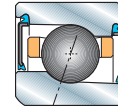

VEX../XN/S

CHROMEK® 40



ISO 10

VEX

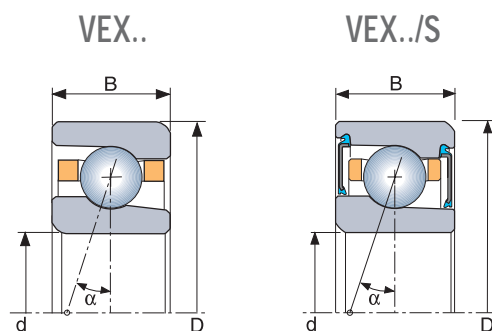

SNFA	d	D	B	z	Ø	$\alpha = 15^\circ$		$\alpha = 25^\circ$		Öl	Fett	Masse
						C33	C0	C33	C0	Vh (ABEC 9)	Vh (ABEC 9)	
VEX 6	6	17	6	8	3.17	160	61			210 000	137 000	0.006
VEX 7	7	19	6	8	3.57	198	77			190 000	124 000	0.008
VEX 8	8	22	7	8	3.97	240	97			165 000	107 000	0.012
VEX 9	9	24	7	9	3.97	260	113			150 000	97 500	0.015
VEX 10	10	26	8	11	3.97	306	143			140 000	91 000	0.019
VEX 12	12	28	8	10	4.76	390	182			125 000	81 000	0.021
VEX 15	15	32	9	12	4.76	450	230			105 000	68 000	0.028
VEX 17	17	35	10	12	5.55	600	310			95 000	62 000	0.035
VEX 20	20	42	12	12	6.35	760	410			80 000	52 000	0.065
VEX 25	25	47	12	14	6.35	840	500	800	480	70 000	45 500	0.078
VEX 30	30	55	13	17	6.35	950	630	900	600	60 000	39 000	0.110
VEX 35	35	62	14	17	7.14	1 170	800	1 110	770	50 000	32 500	0.150
VEX 40	40	68	15	19	7.14	1 250	920	1 180	870	45 000	29 200	0.190
VEX 45	45	75	16	21	7.14	1 310	1 040	1 250	980	41 000	26 700	0.240
VEX 50	50	80	16	21	7.94	1 600	1 270	1 510	1 210	38 000	24 700	0.250
VEX 55	55	90	18	24	7.94	1 710	1 480	1 620	1 400	32 000	20 800	0.400
VEX 60	60	95	18	25	7.94	1 740	1 560	1 650	1 480	30 000	19 500	0.420
VEX 65	65	100	18	25	8.73	2 080	1 880	1 970	1 780	28 000	18 200	0.450
VEX 70	70	110	20	25	9.52	2 430	2 230	2 300	2 110	26 000	16 900	0.640
VEX 75	75	115	20	26	9.52	2 670	2 630	2 520	2 490	24 000	15 600	0.670
VEX 80	80	125	22	25	11.11	3 470	3 400	3 290	3 220	21 600	14 000	0.850
VEX 85	85	130	22	26	11.11	3 540	3 560	3 340	3 370	21 000	13 700	0.900
VEX 90	90	140	24	28	11.11	3 670	3 870	3 470	3 660	19 400	12 600	1.200
VEX 95	95	145	24	26	12.70	4 520	4 630	4 270	4 390	18 600	12 100	1.250
VEX 100	100	150	24	27	12.70	4 600	4 840	4 350	4 580	17 900	11 600	1.300
VEX 110	110	170	28	30	12.70	4 830	5 500	4 560	5 200	15 500	10 100	2.100
VEX 120	120	180	28	29	14.28	5 900	6 600	5 600	6 300	14 000	9 100	2.200

Größere Abmessungen auf Anfrage.

Referenzdrehzahlen Vh für Schrägkugellager mit  $\alpha = 15^\circ$  und Federvorspannung  
Berechnung der Drehzahlgrenzen von Lagersätzen siehe Seite 27.

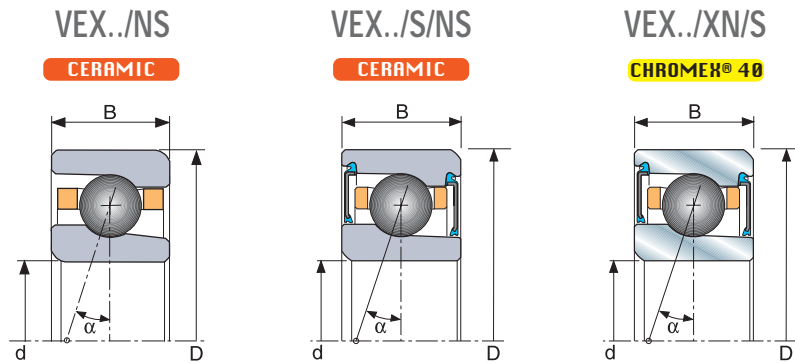

ISO 10

VEX

SNFA						CERAMIC CHROMEX® 40				Öl		Fett	
	d	D	B	z	Ø	α = 15°		α = 25°		Vh	Vh	Vh	Vh
						C33	C0	C33	C0	(ABEC 9)	(ABEC 9)	(ABEC 9)	(ABEC 9)
VEX 6/..	6	17	6	8	3.17	160	44			252 000	164 000	280 000	181 000
VEX 7/..	7	19	6	8	3.57	198	55			228 000	148 000	253 000	164 000
VEX 8/..	8	22	7	8	3.97	240	69			198 000	129 000	220 000	142 000
VEX 9/..	9	24	7	9	3.97	260	81			180 000	117 000	200 000	129 000
VEX 10/..	10	26	8	11	3.97	306	103			168 000	109 000	186 000	121 000
VEX 12/..	12	28	8	10	4.76	390	131			150 000	97 500	167 000	108 000
VEX 15/..	15	32	9	12	4.76	450	166			126 000	82 000	140 000	90 400
VEX 17/..	17	35	10	12	5.55	600	220			114 000	74 100	127 000	82 000
VEX 20/..	20	42	12	12	6.35	760	290			96 000	62 400	107 000	69 000
VEX 25/..	25	47	12	14	6.35	840	360	800	340	84 000	54 600	93 000	60 000
VEX 30/..	30	55	13	17	6.35	950	450	900	430	72 000	46 800	80 000	51 700
VEX 35/..	35	62	14	17	7.14	1 170	580	1 110	550	60 000	39 000	66 500	43 000
VEX 40/..	40	68	15	19	7.14	1 250	660	1 180	630	54 000	35 100	60 000	38 800
VEX 45/..	45	75	16	21	7.14	1 310	740	1 250	700	50 000	32 000	54 500	35 300
VEX 50/..	50	80	16	21	7.94	1 600	910	1 510	870	45 500	29 600	50 500	32 700
VEX 55/..	55	90	18	24	7.94	1 710	1 060	1 620	1 000	38 500	25 000	42 500	27 600
VEX 60/..	60	95	18	25	7.94	1 740	1 120	1 650	1 060	36 000	23 400	40 000	25 800
VEX 65/..	65	100	18	25	8.73	2 080	1 340	1 970	1 270	33 500	21 800	37 500	24 100
VEX 70/..	70	110	20	25	9.52	2 430	1 600	2 300	1 510	31 500	20 300	34 500	22 400
VEX 75/..	75	115	20	26	9.52	2 670	1 880	2 520	1 780	29 000	18 700	32 000	20 700
VEX 80/..	80	125	22	25	11.11	3 470	2 430	3 290	2 300	26 000	16 800	28 500	18 600
VEX 85/..	85	130	22	26	11.11	3 540	2 550	3 340	2 410	25 500	16 400	28 000	18 100
VEX 90/..	90	140	24	28	11.11	3 670	2 770	3 470	2 620	23 500	15 100	26 000	16 700
VEX 95/..	95	145	24	26	12.70	4 520	3 320	4 270	3 140	22 500	14 500	24 500	16 000
VEX 100/..	100	150	24	27	12.70	4 600	3 470	4 350	3 280	21 500	14 000	24 000	15 400
VEX 110/..	110	170	28	30	12.70	4 830	3 910	4 560	3 700	18 500	12 100	20 500	13 300
VEX 120/..	120	180	28	29	14.28	5 900	4 750	5 600	4 500	17 000	10 900	18 600	12 100

Größere Abmessungen auf Anfrage.

Da verbindliche Standards für die Berechnung von dynamischen Tragzahlen C33 für die Paarungen Keramik-Kugeln/100Cr6 bzw. Keramik-Kugeln/Chromex® 40 fehlen, verwendet SNFA die gleichen dynamischen Tragzahlen C33 wie für die Paarung Stahl-Kugeln/100Cr6. Die Anpassung der berechneten Lebensdauerwerte erfolgt mit Faktoren, die auf Erfahrungswerten basieren (siehe Seite 20).



**Vospannungs- und Steifigkeitswerte**  
(fest vorgespannt)  
Druckwinkel = 15°

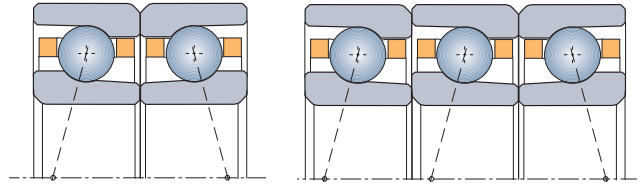

ISO 10

VEX

SNFA	Leichte Vorspannung L			Mittlere Vorspannung M			Starke Vorspannung F		
	Pr	Ra		Pr	Ra		Pr	Ra	
		Paar	Dreier		Paar	Dreier		Paar	Dreier
VEX 6	1.0	0.9	1.3	2.5	1.2	1.7	5.0	1.5	2.2
VEX 7	1.0	0.9	1.3	3.0	1.3	1.9	6.0	1.7	2.4
VEX 8	1.5	1.1	1.6	3.5	1.4	2.1	7.5	1.8	2.7
VEX 9	1.5	1.2	1.7	4.0	1.6	2.4	8.0	2.0	3.0
VEX 10	1.5	1.3	1.9	4.8	1.9	2.8	9.5	2.4	3.6
VEX 12	2.0	1.5	2.2	6.0	2.1	3.1	12.0	2.7	3.9
VEX 15	2.5	1.8	2.6	7.0	2.5	3.7	14.0	3.2	4.6
VEX 17	3.0	2.0	2.9	9.0	2.9	4.2	18.5	3.6	5.4
VEX 20	4.0	2.3	3.4	12.0	3.3	4.9	23.5	4.1	6.1
VEX 25	4.5	2.7	3.9	13.0	3.9	5.5	26.0	4.9	7.0
VEX 30	5.0	3.1	4.6	15.0	4.5	6.6	30.0	5.7	8.3
VEX 35	6.0	3.5	5.1	18.0	5.0	7.3	37.0	6.3	9.3
VEX 40	6.5	3.8	5.6	20.0	5.5	8.1	39.0	6.9	10.2
VEX 45	7.0	4.2	6.1	21.0	6.0	8.8	41.0	7.5	11.1
VEX 50	8.5	4.6	6.8	25.0	6.6	9.7	50.0	8.3	12.2
VEX 55	9.0	5.1	7.6	27.0	7.4	10.9	54.0	9.3	13.7
VEX 60	9.2	5.3	7.8	27.5	7.7	11.3	55.0	9.6	14.2
VEX 65	11.0	5.8	8.6	33.0	8.4	12.4	65.0	10.5	15.5
VEX 70	13.0	6.3	9.3	38.0	9.1	13.3	76.0	11.4	16.8
VEX 75	14.0	6.7	9.8	42.0	9.6	14.1	84.0	12.1	17.8
VEX 80	18.0	7.4	10.9	55.0	10.8	15.9	109.0	13.5	19.9
VEX 85	18.5	7.7	11.3	56.0	11.1	16.4	111.0	14.0	20.6
VEX 90	19.0	8.2	12.0	58.0	11.8	17.4	115.0	14.9	21.9
VEX 95	23.0	8.7	12.7	70.0	12.5	18.5	140.0	15.8	23.3
VEX 100	24.0	9.0	13.2	72.0	13.0	19.1	144.0	16.4	24.1
VEX 110	25.0	9.8	14.4	76.0	14.2	20.9	152.0	17.9	26.3
VEX 120	31.0	10.7	15.7	93.0	15.4	22.7	185.0	19.4	28.5



**Vospannungs- und Steifigkeitswerte**  
(fest vorgespannt)  
Druckwinkel = 25°

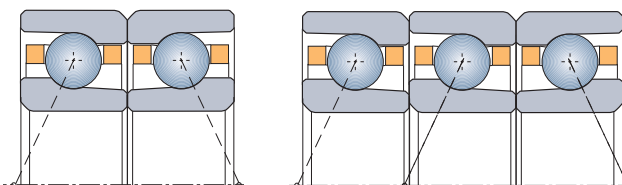

ISO 10

VEX

SNFA	Leichte Vorspannung L			Mittlere Vorspannung M			Starke Vorspannung F		
	Pr	Ra		Pr	Ra		Pr	Ra	
		Paar	Dreier		Paar	Dreier		Paar	Dreier
VEX 25	7.0	6.9	10.2	21.0	10.0	14.7	43.0	12.7	18.7
VEX 30	8.0	8.2	12.1	24.0	11.9	17.5	48.0	15.0	22.0
VEX 35	10.0	9.2	13.6	30.0	13.3	19.6	59.0	16.7	24.6
VEX 40	10.5	10.1	14.9	31.0	14.5	21.3	63.0	18.4	27.0
VEX 45	11.0	11.0	16.1	33.0	15.8	23.3	66.0	19.9	29.3
VEX 50	13.0	12.0	17.7	40.0	17.5	25.7	80.0	22.0	32.4
VEX 55	14.0	13.5	19.8	43.0	19.6	28.8	86.0	24.7	36.3
VEX 60	15.0	14.2	20.8	44.0	20.3	29.8	87.0	25.4	37.4
VEX 65	17.0	15.2	22.4	52.0	22.1	32.5	104.0	27.9	41.0
VEX 70	20.0	16.6	24.4	61.0	24.0	35.3	122.0	30.3	44.5
VEX 75	22.0	17.5	25.8	67.0	25.4	37.4	134.0	32.0	47.2
VEX 80	28.0	19.5	28.7	85.0	28.2	41.5	170.0	35.6	52.3
VEX 85	29.0	20.3	29.8	89.0	29.4	43.3	178.0	37.1	54.6
VEX 90	30.0	21.5	31.7	92.0	31.3	46.0	184.0	39.4	58.0
VEX 95	38.0	23.2	34.1	113.0	33.3	49.0	227.0	42.0	61.9
VEX 100	39.0	24.0	35.3	115.0	34.4	50.6	231.0	43.4	63.8
VEX 110	40.0	25.9	38.2	121.0	37.5	55.2	242.0	47.2	69.5
VEX 120	49.0	28.2	41.5	148.0	40.8	60.0	295.0	51.3	75.5



# E 200

ISO 02

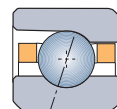

E 200



ISO 02

E 200

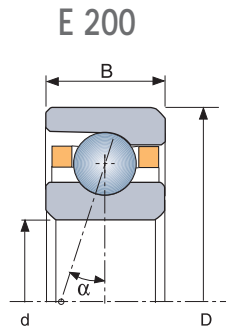

SNFA	d	D	B	z	Ø	$\alpha = 15^\circ$		$\alpha = 25^\circ$		Öl	Fett	Masse
						C33	C0	C33	C0	Vh (ABEC 9)	Vh (ABEC 9)	
E 207	7	22	7	8	3.97	365	194	350	187	121 000	78 700	0.012
E 208	8	24	8	7	4.76	455	230	440	220	109 500	71 200	0.016
E 209	9	26	8	9	4.76	550	320	530	300	100 000	65 000	0.021
E 210	10	30	9	8	5.55	655	370	640	360	87 000	56 600	0.029
E 212	12	32	10	9	5.55	720	440	695	420	79 500	51 700	0.035
E 215	15	35	11	9	6.35	915	570	885	550	69 500	45 200	0.042
E 217	17	40	12	9	7.14	1 140	720	1 090	700	61 000	39 700	0.060
E 220	20	47	14	11	7.14	1 315	940	1 260	910	51 500	33 500	0.105
E 225	25	52	15	12	7.94	1 720	1 290	1 640	1 230	44 500	28 900	0.125
E 230	30	62	16	12	9.52	2 350	1 850	2 250	1 770	37 000	24 000	0.194
E 235	35	72	17	14	9.52	2 600	2 270	2 480	2 170	31 500	20 500	0.300
E 240	40	80	18	14	11.11	3 430	3 050	3 280	2 920	28 500	18 500	0.359
E 245	45	85	19	15	11.11	3 590	3 350	3 410	3 200	25 500	16 600	0.414
E 250	50	90	20	14	12.70	4 370	4 010	4 150	3 830	24 000	15 600	0.442
E 255	55	100	21	14	14.28	5 560	5 000	5 300	4 830	21 000	13 700	0.591
E 260	60	110	22	15	14.28	5 770	5 600	5 490	5 300	19 400	12 600	0.782
E 265	65	120	23	15	15.87	6 800	6 800	6 490	6 500	17 800	11 600	0.980
E 270	70	125	24	16	15.87	7 085	7 400	6 730	7 100	16 700	10 900	1.084
E 275	75	130	25	17	15.87	7 345	8 000	6 980	7 600	15 600	10 100	1.188
E 280	80	140	26	17	17.46	8 960	9 600	8 490	9 100	14 400	9 400	1.417
E 285	85	150	28	16	19.05	9 830	10 700	9 330	10 200	13 300	8 600	1.755
E 290	90	160	30	15	22.22	12 490	13 200	11 920	12 700	12 800	8 300	2.212
E 295	95	170	32	17	20.64	11 780	13 400	11 190	12 800	11 700	7 600	2.720
E 200/100	100	180	34	16	23.81	14 740	16 400	14 050	15 700	11 100	7 200	3.267
E 200/105	105	190	36	16	25.40	17 030	18 600	16 190	17 800	10 300	6 700	4.000
E 200/110	110	200	38	17	25.40	17 670	20 100	16 760	19 100	10 000	6 500	4.630
E 200/120	120	215	40	18	25.40	17 900	21 700	16 900	20 700	9 100	5 900	5.600
E 200/130	130	230	40	17	28.57	20 400	25 600	19 400	24 400	8 300	5 400	6.300
E 200/140	140	250	42	18	30.16	23 140	30 400	21 900	29 000	7 400	4 800	8.260

Größere Abmessungen auf Anfrage.

Referenzdrehzahlen Vh für Schrägkugellager mit  $\alpha = 15^\circ$  und Federvorspannung  
 Berechnung der Drehzahlgrenzen von Lagersätzen siehe Seite 27.

**Vospannungs- und Steifigkeitswerte  
(fest vorgespannt)**  
Druckwinkel = 15°

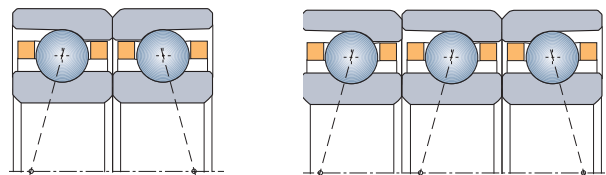

ISO 02

E 200

SNFA	Leichte Vorspannung L			Mittlere Vorspannung M			Starke Vorspannung F		
	Pr	Ra		Pr	Ra		Pr	Ra	
		Paar	Dreier		Paar	Dreier		Paar	Dreier
E 207	2.0	1.2	1.7	6.0	1.7	2.5	12.0	2.2	3.2
E 208	2.3	1.2	1.8	7.0	1.8	2.6	14.0	2.2	3.2
E 209	2.9	1.5	2.3	8.7	2.2	3.3	17.0	2.8	4.1
E 210	3.5	1.6	2.4	10.5	2.3	3.4	21.0	2.9	4.3
E 212	3.5	1.8	2.6	11.5	2.5	3.7	23.0	3.2	4.7
E 215	4.8	2.0	2.9	14.4	2.8	4.2	28.8	3.6	5.3
E 217	6.0	2.3	3.3	18.0	3.2	4.8	36.0	4.0	6.0
E 220	7.0	2.7	4.0	21.0	3.9	5.7	42.0	4.9	7.2
E 225	9.0	3.2	4.8	27.0	4.7	6.9	54.0	5.9	8.6
E 230	12.0	3.8	5.6	36.5	5.5	8.1	73.0	6.9	10.1
E 235	13.5	4.4	6.4	41.0	6.3	9.2	82.0	7.9	11.6
E 240	18.0	5.0	7.4	54.5	7.2	10.7	109.0	9.2	13.5
E 245	18.7	5.3	7.9	56.0	7.7	11.4	112.0	9.7	14.3
E 250	22.8	5.7	8.4	68.5	8.2	12.1	137.0	10.4	15.3
E 255	29.0	6.4	9.5	87.0	9.3	13.7	174.0	11.7	17.2
E 260	30.5	6.9	10.1	92.0	9.9	14.6	184.0	12.5	18.4
E 265	35.5	7.5	11.0	107.0	10.8	15.9	214.0	13.5	20.0
E 270	37.0	7.9	11.6	111.0	11.4	16.8	222.0	14.3	21.1
E 275	38.5	8.3	12.3	115.0	12.0	17.7	230.0	15.0	22.3
E 280	46.0	9.1	13.4	138.0	13.2	19.4	276.0	16.6	24.4
E 285	51.5	9.3	13.8	154.5	13.5	19.9	309.0	17.0	25.1
E 290	65.5	10.2	15.1	196.0	14.7	21.7	392.0	18.6	27.4
E 295	61.5	10.7	15.7	185.0	15.6	22.6	370.0	19.3	28.5
E 200/100	77.0	11.5	17.0	231.0	16.5	24.5	462.0	21.0	30.9
E 200/105	89.0	12.4	18.2	267.0	17.9	26.3	534.0	22.5	33.1
E 200/110	92.0	13.0	19.2	276.0	18.8	27.7	552.0	23.7	34.9
E 200/120	95.0	13.7	20.2	280.0	19.6	28.9	560.0	24.7	36.4
E 200/130	107.0	14.3	21.0	320.0	20.6	30.2	641.0	25.9	38.1
E 200/140	121.0	15.7	23.1	363.0	22.7	33.3	726.0	28.6	42.0



**Vospannungs- und Steifigkeitswerte**  
(fest vorgespannt)  
Druckwinkel = 25°

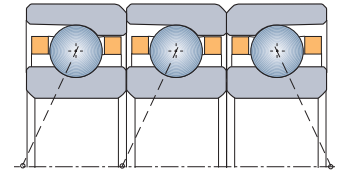
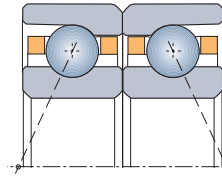

ISO 02

E 200

SNFA	Leichte Vorspannung L			Mittlere Vorspannung M			Starke Vorspannung F		
	Pr	Ra		Pr	Ra		Pr	Ra	
		Paar	Dreier		Paar	Dreier		Paar	Dreier
E 207	3.0	3.1	4.5	9.0	4.4	6.5	18.0	5.6	8.2
E 208	3.5	3.1	4.6	10.5	4.5	6.7	21.0	5.7	8.4
E 209	4.7	4.1	6.0	14.0	5.9	8.7	28.0	7.4	10.9
E 210	5.6	4.3	6.2	17.0	6.6	9.0	34.0	7.6	11.4
E 212	6.0	4.8	6.9	18.5	6.8	10.0	37.0	8.6	12.6
E 215	8.0	5.4	7.9	23.7	7.7	11.4	47.4	9.7	14.3
E 217	9.6	6.0	8.8	29.0	8.6	12.7	58.0	10.9	16.0
E 220	11.5	7.2	10.6	34.0	10.3	15.0	68.0	13.0	19.2
E 225	15.0	8.7	12.8	44.0	12.4	18.3	87.0	15.6	23.0
E 230	20.0	10.1	14.9	60.0	14.6	21.5	120.0	18.3	27.1
E 235	22.0	11.7	17.1	66.5	16.7	24.6	132.5	21.0	31.0
E 240	29.5	13.4	19.7	88.0	19.3	28.4	176.0	24.3	35.0
E 245	30.0	14.1	20.9	90.0	20.4	30.1	180.0	25.8	37.9
E 250	36.7	15.3	22.3	110.0	21.8	32.1	220.0	27.5	40.5
E 255	46.0	17.0	25.0	138.0	24.5	36.1	276.0	30.9	45.4
E 260	48.0	18.0	26.6	144.0	26.0	38.3	288.0	32.8	48.2
E 265	57.3	20.0	29.2	172.0	28.6	42.1	344.0	36.0	53.0
E 270	59.5	21.2	30.8	178.5	30.1	44.5	357.0	38.0	56.0
E 275	61.7	22.0	32.5	185.0	31.8	46.9	370.0	39.3	59.1
E 280	75.0	24.3	35.8	225.0	35.1	51.6	450.0	44.2	65.1
E 285	82.5	24.8	36.5	247.5	35.8	52.7	495.0	45.0	66.4
E 290	105.3	27.2	40.0	316.0	38.9	57.7	632.0	49.3	72.6
E 295	99.0	27.9	41.5	297.0	40.6	59.9	594.0	51.2	75.5
E 200/100	124.2	30.7	45.1	372.5	44.2	65.1	745.0	55.7	82.0
E 200/105	143.0	32.8	48.3	429.0	47.4	69.7	858.0	59.7	87.8
E 200/110	148.0	34.6	50.9	444.0	49.9	73.4	888.0	62.9	92.5
E 200/120	150.0	36.1	53.1	450.0	52.1	76.6	900.0	65.6	96.5
E 200/130	171.0	37.8	55.6	513.0	54.5	80.1	1 027.0	68.6	101.0
E 200/140	194.0	41.6	61.3	582.0	60.0	88.4	1 164.0	75.7	111.3

# BS 200

ISO 02

# BS SPECIALE

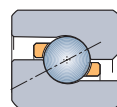

BS 200

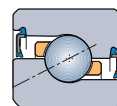

BS../S



ISO 02

BS 200

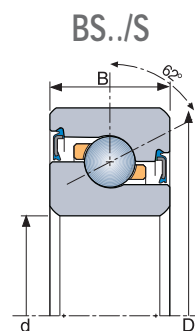
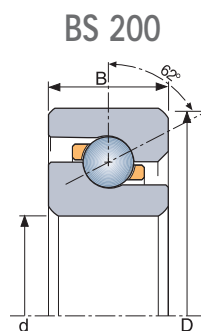

SNFA	d	D	B	z	Ø	C33	Co	Öl	Fett	Masse
								Vh (ABEC 7)	Vh (ABEC 7)	
BS 212	12	32	10	10	4.76	945	1 440	23 000	15 000	0.037
BS 215	15	35	11	14	4.76	1 130	2 050	20 000	13 000	0.047
BS 217*	17	40	12	12	5.55	1 365	2 380	17 700	11 500	0.069
BS 220	20	47	14	13	6.35	1 820	3 380	15 200	9 900	0.111
BS 225	25	52	15	16	6.35	2 000	4 240	13 200	8 600	0.138
BS 230	30	62	16	16	7.14	2 460	5 400	11 100	7 200	0.220
BS 235	35	72	17	17	7.49	3 055	7 100	9 600	6 200	0.320
BS 240	40	80	18	18	8.73	3 745	9 100	8 600	5 600	0.400
BS 245	45	85	19	19	8.73	3 785	9 700	7 800	5 100	0.460
BS 250	50	90	20	20	8.73	3 835	10 300	7 400	4 800	0.520
BS 260	60	110	22	19	11.11	5 805	15 800	6 100	3 950	0.860
BS 275	75	130	25	24	11.11	6 400	20 200	4 800	3 100	1.500

Abgedichtete Versionen auf Anfrage.

\* Auf Anfrage

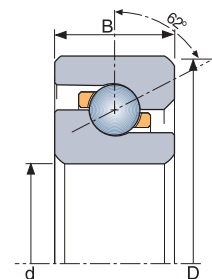

SPECIALE

BS

SNFA	d	D	B	z	Ø	C33	Co	Öl	Fett	Masse
								Vh (ABEC 7)	Vh (ABEC 7)	
BS 17/47	17	47	15	13	6.35	1 820	3 380	15 200	9 900	0.138
BS 20/47	20	47	15	13	6.35	1 820	3 380	15 200	9 900	0.128
BS 25/62	25	62	15	16	7.14	2 460	5 400	11 100	7 200	0.242
BS 30/62	30	62	15	16	7.14	2 460	5 400	11 100	7 200	0.217
BS 35/72	35	72	15	17	7.94	3 055	7 100	9 600	6 200	0.282

Referenzdrehzahlen Vh für Schrägkugellager mit  $\alpha = 15^\circ$  und Federvorspannung  
Berechnung der Drehzahlgrenzen von Lagersätzen siehe Seite 27.



ISO 02

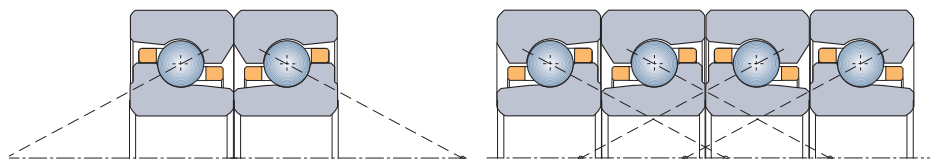

SNFA	PAAR				4er SÄTZE				Max. Axialschlag (µm)
	Pr	Ra	La	Cr	Pr	Ra	La	Cr	
BS 212	100	42	625	2.8	200	84	1 250	5.6	2.5
BS 215	140	58	850	4	280	116	1 700	8	2.5
BS 217*	165	58	1 030	6	330	116	2 060	12	2.5
BS 220	230	72	1 450	10	460	144	2 900	20	2.5
BS 225	280	88	1 800	12	560	176	3 600	23	2.5
BS 230	360	100	2 260	19	720	200	4 520	37	2.5
BS 235	475	118	2 960	33	950	236	5 920	67	2.5
BS 240	600	137	3 790	41	1 200	274	7 580	81	2.5
BS 245	640	145	4 020	47	1 280	290	8 040	92	2.5
BS 250	680	153	4 220	53	1 360	306	8 440	106	2.5
BS 260	1 040	185	6 500	88	2 080	370	13 000	176	2.5
BS 275	1 310	233	7 600	169	2 620	466	15 200	338	2.5

\* Auf Anfrage

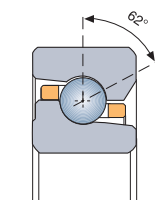

SPECIALE

SNFA	PAAR				4er SÄTZE				Max. Axialschlag (µm)
	Pr	Ra	La	Cr	Pr	Ra	La	Cr	
BS 17/47	230	72	1 450	10	460	144	2 900	20	2.5
BS 20/47	230	72	1 450	10	460	144	2 900	20	2.5
BS 25/62	360	100	2 260	19	720	200	4 520	37	2.5
BS 30/62	360	100	2 260	19	720	200	4 520	37	2.5
BS 35/72	475	118	2 960	33	950	236	5 920	67	2.5

BS

# Gehäuseeinheiten mit Kugellagern für Kugelumlaufspindeln BSDU

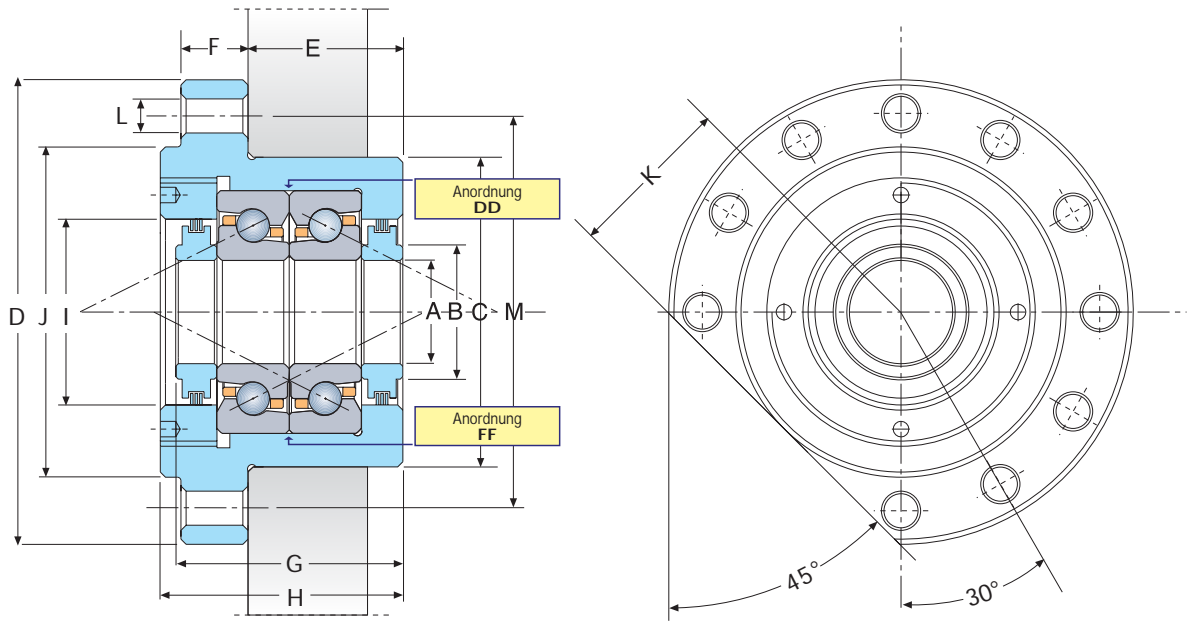

Durch. der Wellen mm	SNFA	Abmessungen: ± 0.13 mm													C33	Co	Cr	Ra	Max. Axialschlag µm	Masse	Vg*
		A	B	C	D	E	F	G	H	I	J	K	L	M							
17	BSDU 217 DD 230	17.000	26.0	60.000	90.0	32.0	13.0	44.260	47.0	36.0	64.0	32.0	6.6	76.0	1820	3380	10	72	2.5	1.1	3 900
	BSDU 217 FF 230	16.996		59.987				43.240													
20	BSDU 220 DD 230	20.000	26.0	60.000	90.0	32.0	13.0	44.260	47.0	36.0	64.0	32.0	6.6	76.0	1820	3380	10	72	2.5	1.1	3 900
	BSDU 220 FF 230	19.996		59.987				43.240													
25	BSDU 225 DD 280	25.000	34.0	80.000	120.0	32.0	15.0	50.260	52.0	36.0	88.0	44.0	9.2	102.0	2000	4240	12	88	2.5	2.3	3 400
	BSDU 225 FF 280	24.996		79.987				49.240													
30	BSDU 230 DD 360	30.000	41.0	80.000	120.0	32.0	15.0	50.260	52.0	50.0	88.0	44.0	9.2	102.0	2460	5400	19	100	2.5	2.3	2 850
	BSDU 230 FF 360	29.996		79.987				49.240													
35	BSDU 235 DD 475	35.000	46.0	90.000	130.0	32.0	15.0	50.260	52.0	60.0	98.0	49.0	9.2	113.0	3055	7100	33	118	2.5	3.2	2 500
	BSDU 235 FF 475	34.995		89.987				49.240													
40	BSDU 240 DD 600	40.000	55.0	124.000	165.0	43.5	17.0	64.260	66.0	66.0	128.0	64.0	11.4	146.0	3745	9100	41	137	2.5	6.1	2 200
	BSDU 240 FF 600	39.995		123.982				63.240													
45	BSDU 245 DD 640	45.000	66.0	124.000	165.0	43.5	17.0	64.260	66.0	76.0	128.0	64.0	11.4	146.0	3785	9700	47	145	2.5	5.9	2 000
	BSDU 245 FF 640	44.995		123.982				63.240													
50	BSDU 250 DD 680	50.000	66.0	124.000	165.0	43.5	17.0	64.260	66.0	76.0	128.0	64.0	11.4	146.0	3835	10300	53	153	2.5	5.7	1 900
	BSDU 250 FF 680	49.995		123.982				63.240													

Die Endzahlen der Bezeichnung zeigen die Lagervorspannung in daN an. Auf Anfrage können Spezialvorspannungen ausgeführt werden.

\* Max Drehzahl bei Fettschmierung. Die Gehäuseeinheit wird mit Fett Klüber NBU 15 geschmiert.

# Gehäuseeinheiten mit Kugellagern für Kugelumlaufspindeln BSQU

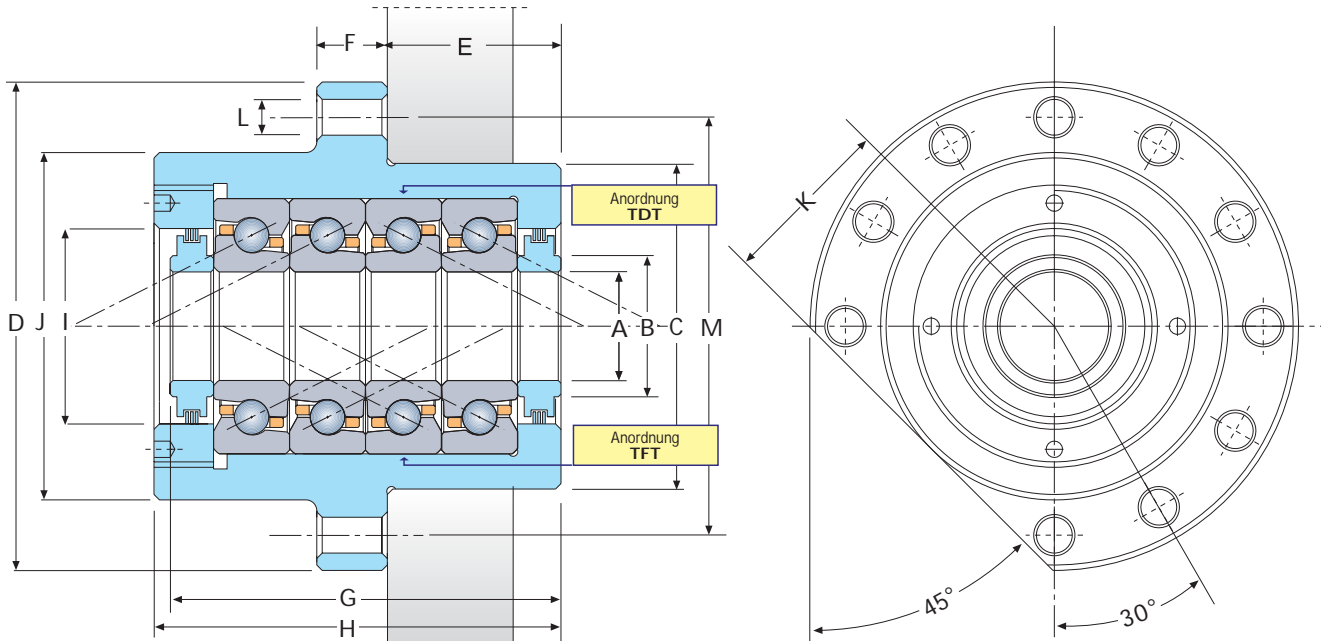

Durch. der Wellen mm	SNFA	Abmessungen: ± 0.13 mm													C33	Co	Cr	Ra	Max. Axialschlag µm	Masse	Vg*
		A	B	C	D	E	F	G	H	I	J	K	L	M							
20	BSQU 220 TDT 460	20.000	26.0	60.000	90.0	32.0	13.0	74.260	77.0	36.0	64.0	32.0	6.6	76.0	2950	6760	20	144	<b>2.5</b>	1.7	3250
	BSQU 220 TFT 460	19.996		59.987				72.740													
25	BSQU 225 TDT 560	25.000	34.0	80.000	120.0	32.0	15.0	80.260	82.0	40.0	88.0	44.0	9.2	102.0	3240	8480	23	176	<b>2.5</b>	3.5	2850
	BSQU 225 TFT 560	24.996		79.987				78.740													
30	BSQU 230 TDT 720	30.000	41.0	80.000	120.0	32.0	15.0	82.260	84.0	50.0	88.0	44.0	9.2	102.0	3985	10800	37	200	<b>2.5</b>	3.5	2400
	BSQU 230 TFT 720	29.996		79.987				80.740													
35	BSQU 235 TDT 950	35.000	46.0	90.000	130.0	32.0	15.0	84.260	86.0	60.0	98.0	49.0	9.2	113.0	4950	14200	67	236	<b>2.5</b>	4.6	2100
	BSQU 235 TFT 950	34.995		89.987				82.740													
40	BSQU 240 TDT 1200	40.000	55.0	124.000	165.0	43.5	17.0	104.260	106.0	66.0	128.0	64.0	11.4	146.0	6070	18200	81	274	<b>2.5</b>	9.7	1900
	BSQU 240 TFT 1200	39.995		123.982				102.740													
45	BSQU 245 TDT 1280	45.000	66.0	124.000	165.0	43.5	17.0	104.260	106.0	76.0	128.0	64.0	11.4	146.0	6130	19400	92	290	<b>2.5</b>	9.4	1700
	BSQU 245 TFT 1280	44.995		123.982				102.740													
50	BSQU 250 TDT 1360	50.000	66.0	124.000	165.0	43.5	17.0	104.260	106.0	76.0	128.0	64.0	11.4	146.0	6210	20600	106	306	<b>2.5</b>	9.1	1550
	BSQU 250 TFT 1360	49.995		123.982				102.740													

Die Endzahlen der Bezeichnung zeigen die Lagervorspannung in daN an. Auf Anfrage können Spezialvorspannungen ausgeführt werden.

\* Max Drehzahl bei Fettschmierung. Die Gehäuseeinheit wird mit Fett Klüber Isoflex NBU 15 geschmiert.

# Gehäuseeinheiten mit Kugellagern für Kugelumlaufspindeln BSqu/1

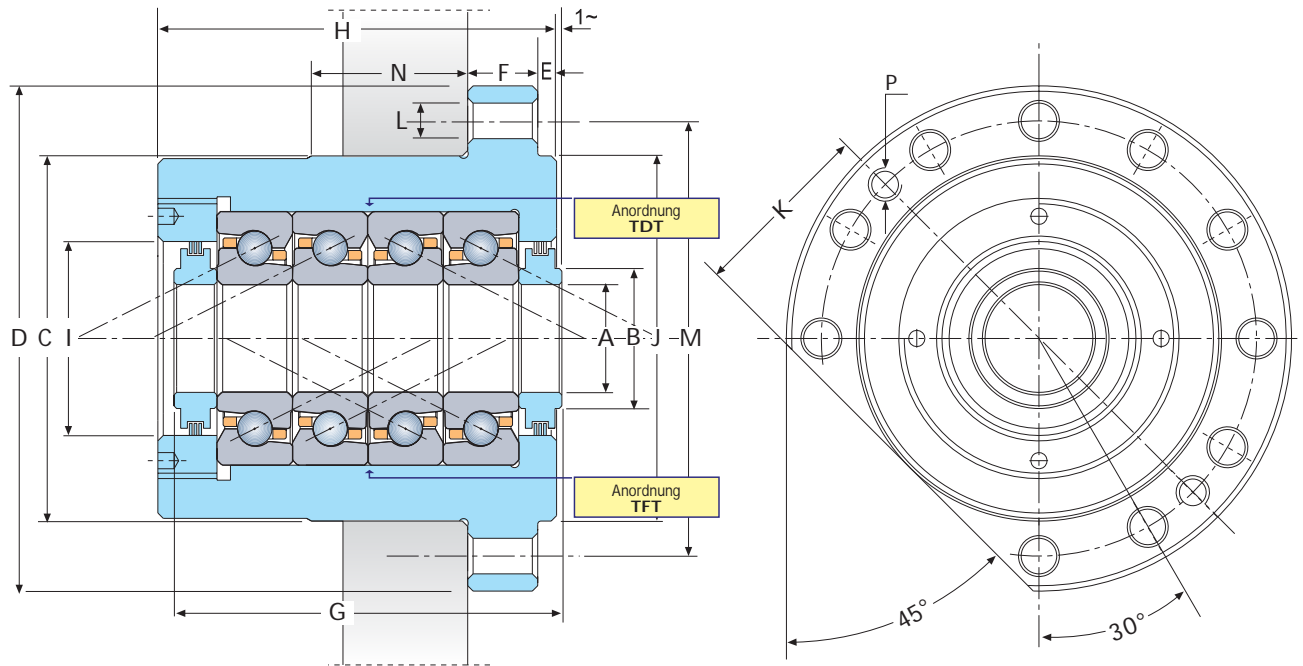

Durch. der Wellen mm	SNFA	Abmessungen: $\pm 0.13$ mm																C <sub>33</sub>	C <sub>o</sub>	C <sub>r</sub>	Ra	Max. Axial- schlag $\mu$ m	Masse	Vg*
		A	B	C	D	E	F	G	H	I	J	K	L	M	N	P								
30	BSQU 230/1 TDT 720	30.000	41.0	88.000	120.0	3.5	15.0	86.260	86.0	50.0	88.0	45.0	9.2	102.0	35.0	M8x 1.25	3985	10800	37	200	<b>2.5</b>	3.7	2400	
	BSQU 230/1 TFT 720	29.996		87.985				84.740																
40	BSQU 240/1 TDT 1200	40.000	55.0	128.000	165.0	4.0	24.0	106.260	106.0	66.0	128.0	65.5	11.4	146.0	35.0	M10x 1.5	6070	18200	81	274	<b>2.5</b>	10.0	1900	
	BSQU 240/1 TFT 1200	39.995		127.982				104.740																
50	BSQU 250/1 TDT 1360	50.000	66.0	128.000	165.0	4.0	24.0	106.260	106.0	76.0	128.0	65.5	11.4	146.0	35.0	M10x 1.5	6210	20600	106	306	<b>2.5</b>	9.3	1550	
	BSQU 250/1 TFT 1360	49.995		127.982				104.740																
60	BSQU 260/1 TDT 2080	60.000	80.0	145.000	185.0	20.5	25.0	114.260	114.0	92.0	145.0	74.5	11.4	165.0	40.0	M10x 1.5	9400	31600	176	370	<b>2.5</b>	12.3	1300	
	BSQU 260/1 TFT 2080	59.993		144.982				112.740																

Anwendungsbeispiele und Montage.....  
für SNFA Präzisions-Schräggugellager

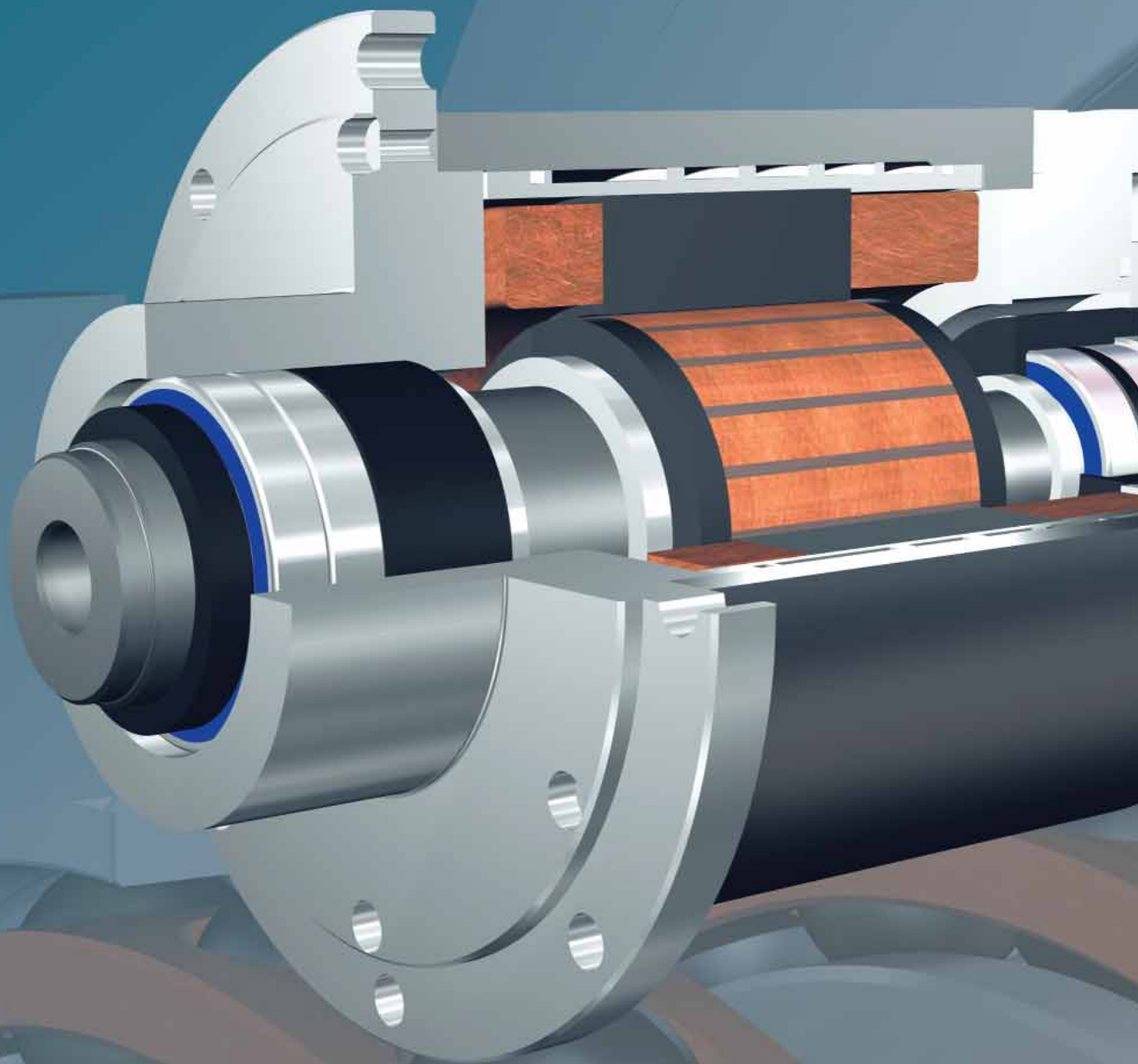

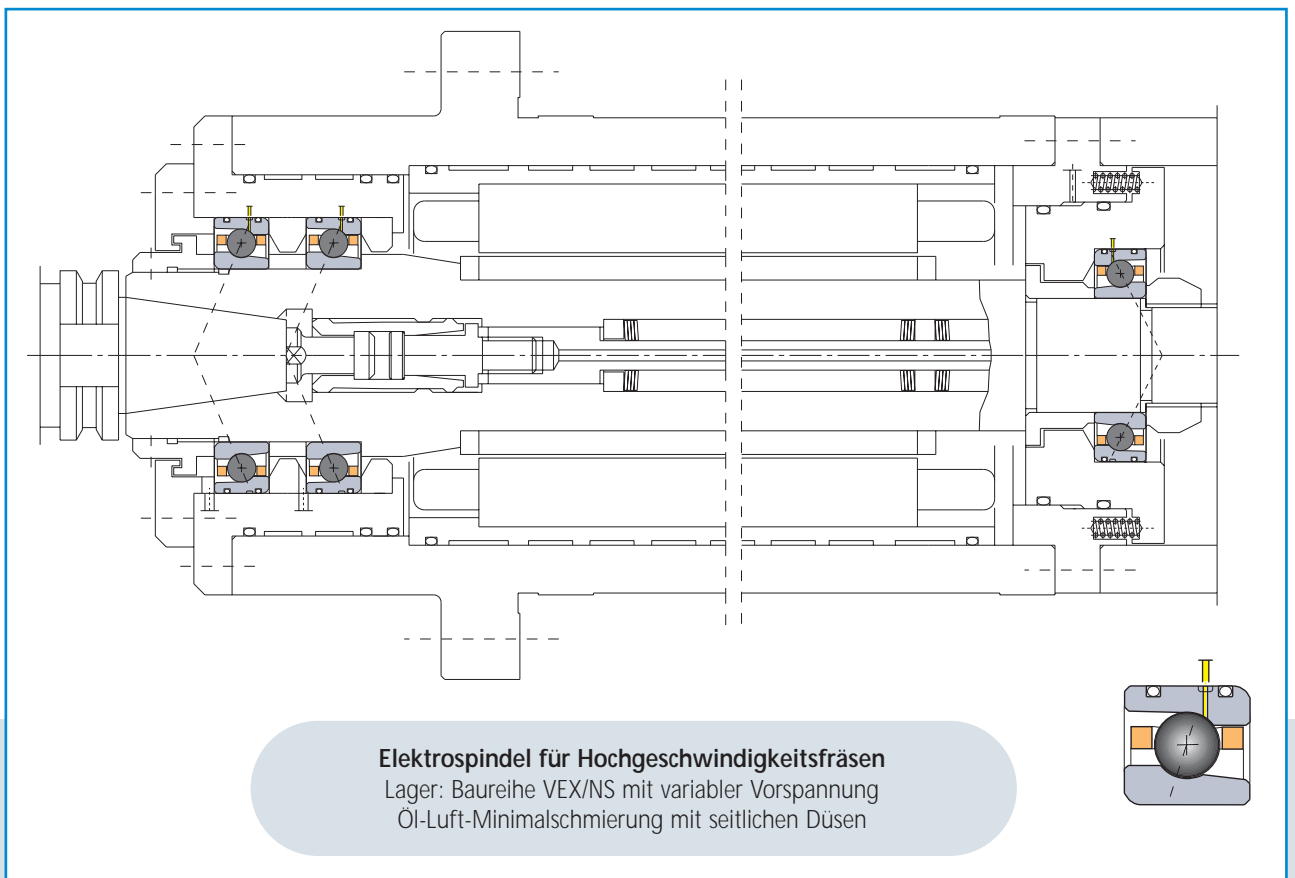
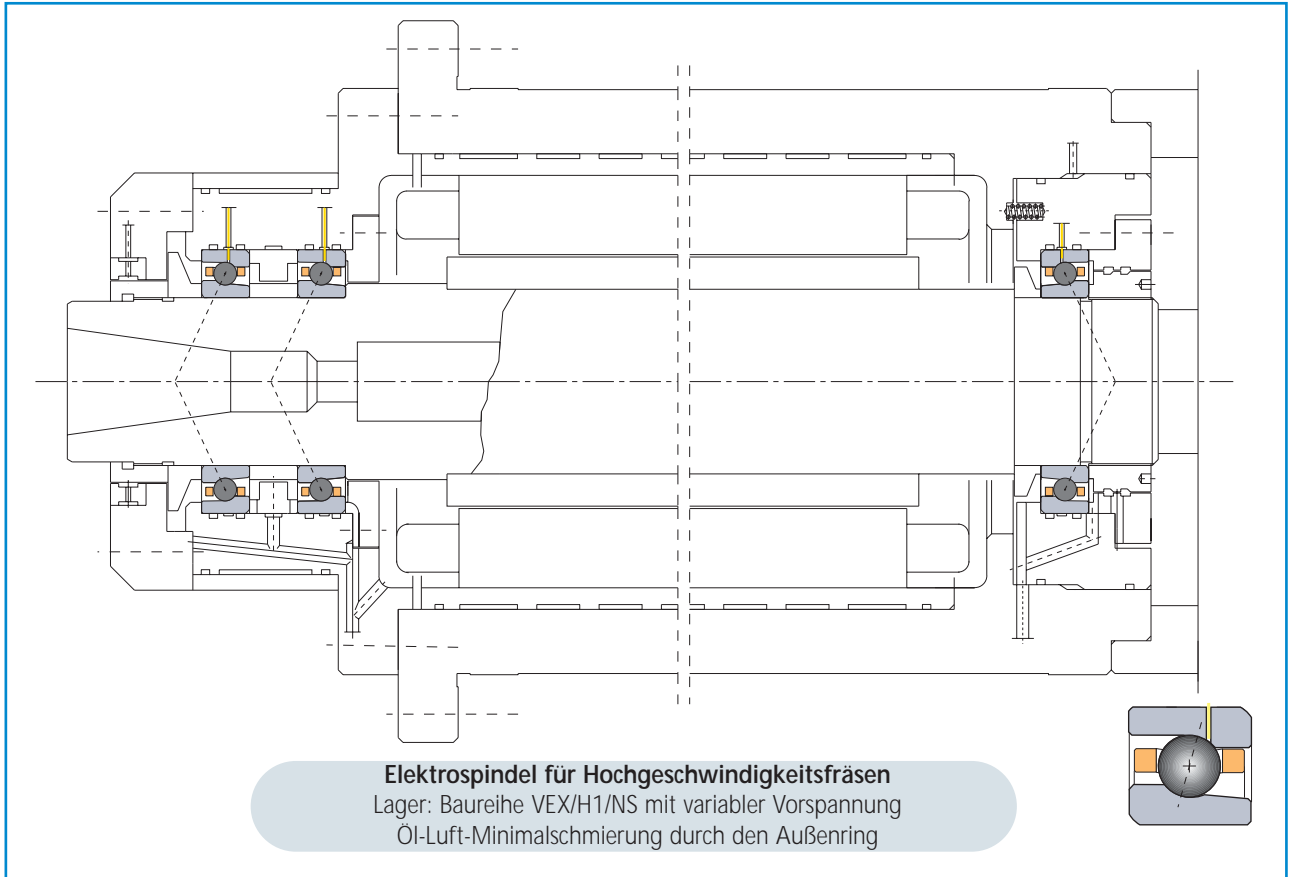

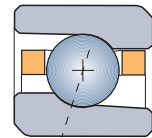
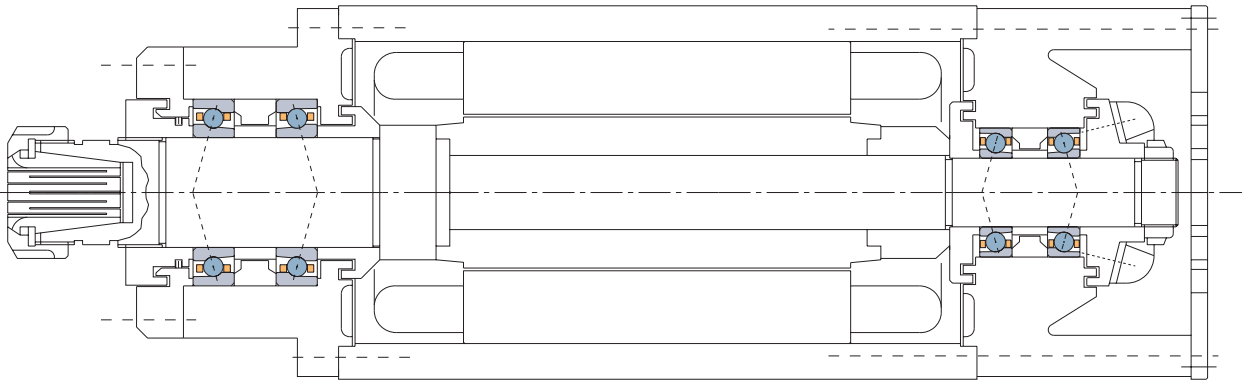

**Elektrospindel für Schnellfräsen**  
Lager: Baureihe VEX - Fettschmierung

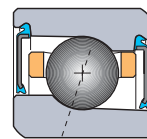
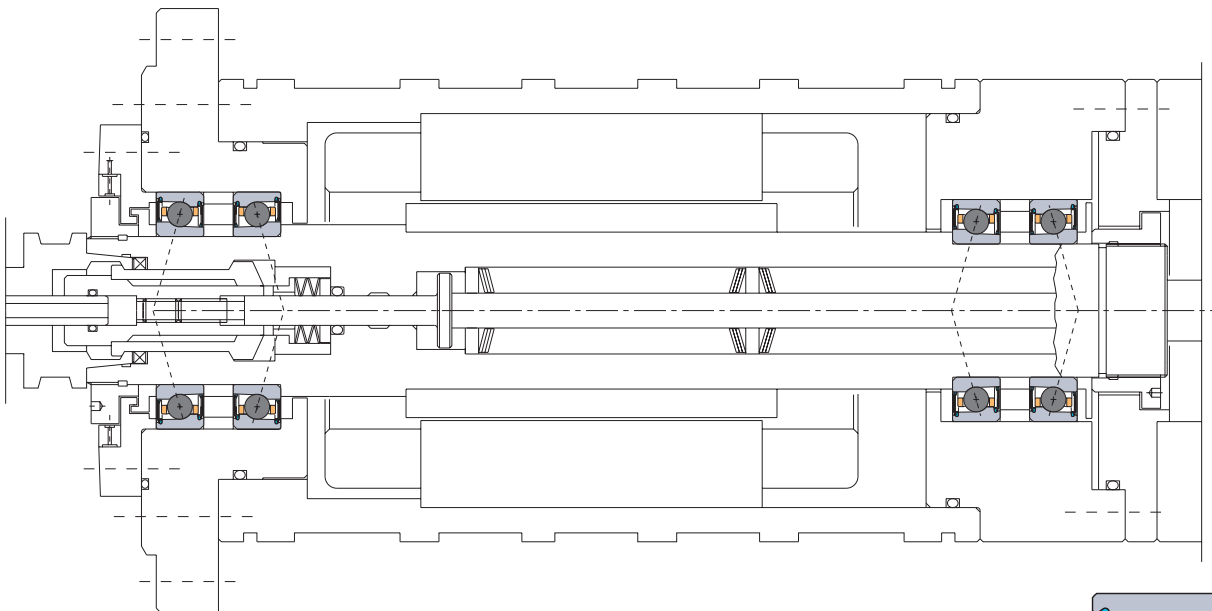

**Elektrospindel für Schnellfräsen**  
Lager: Baureihe VEX - Fettschmierung

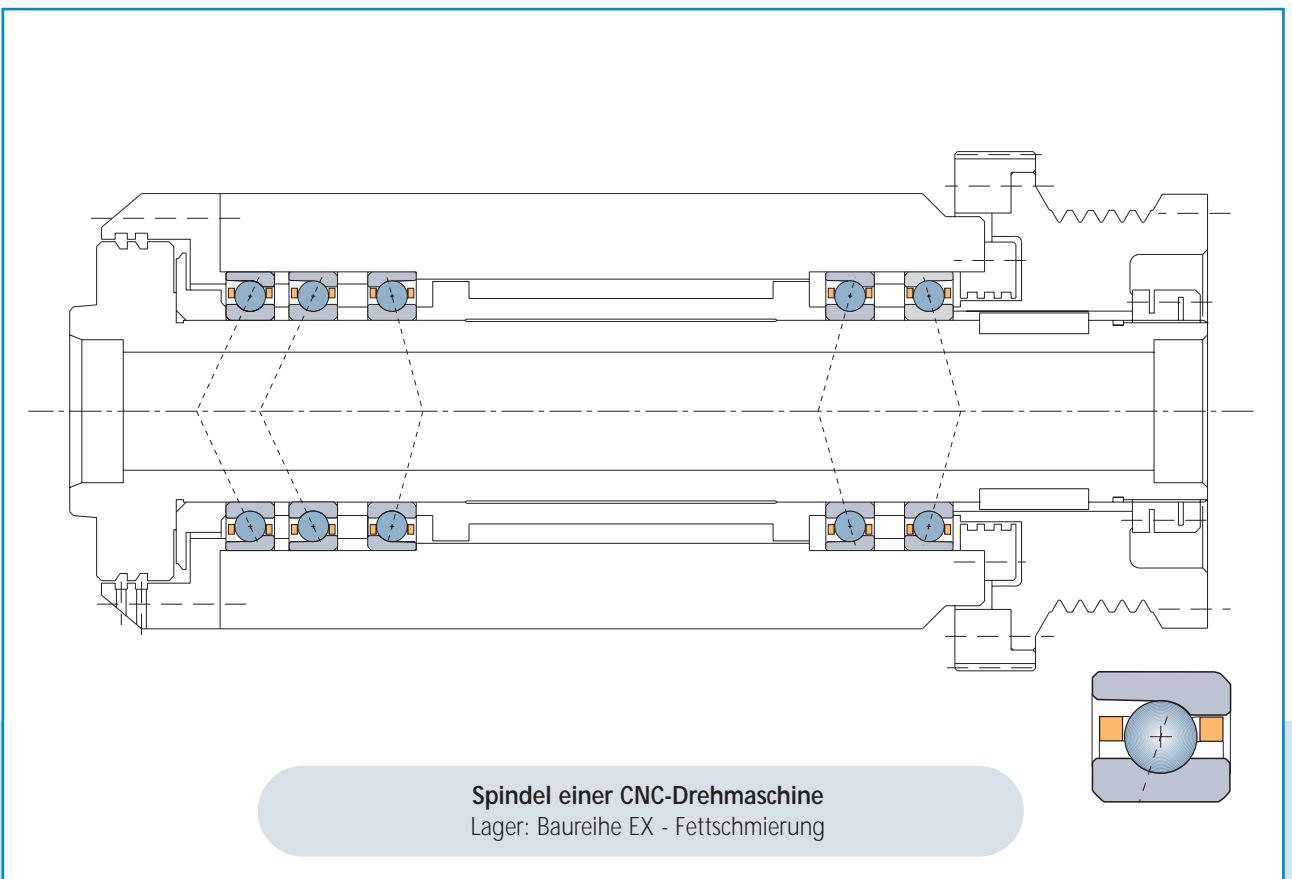
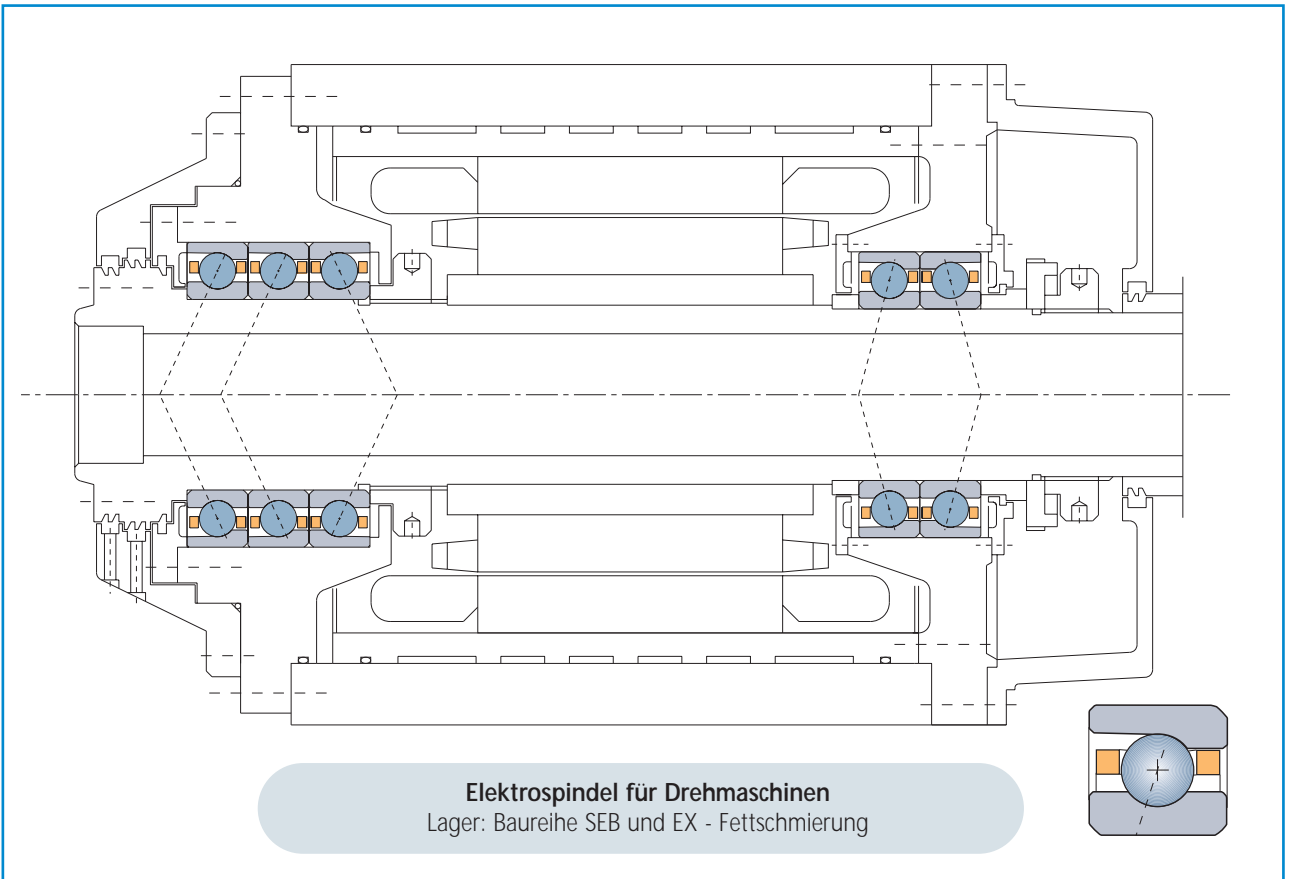



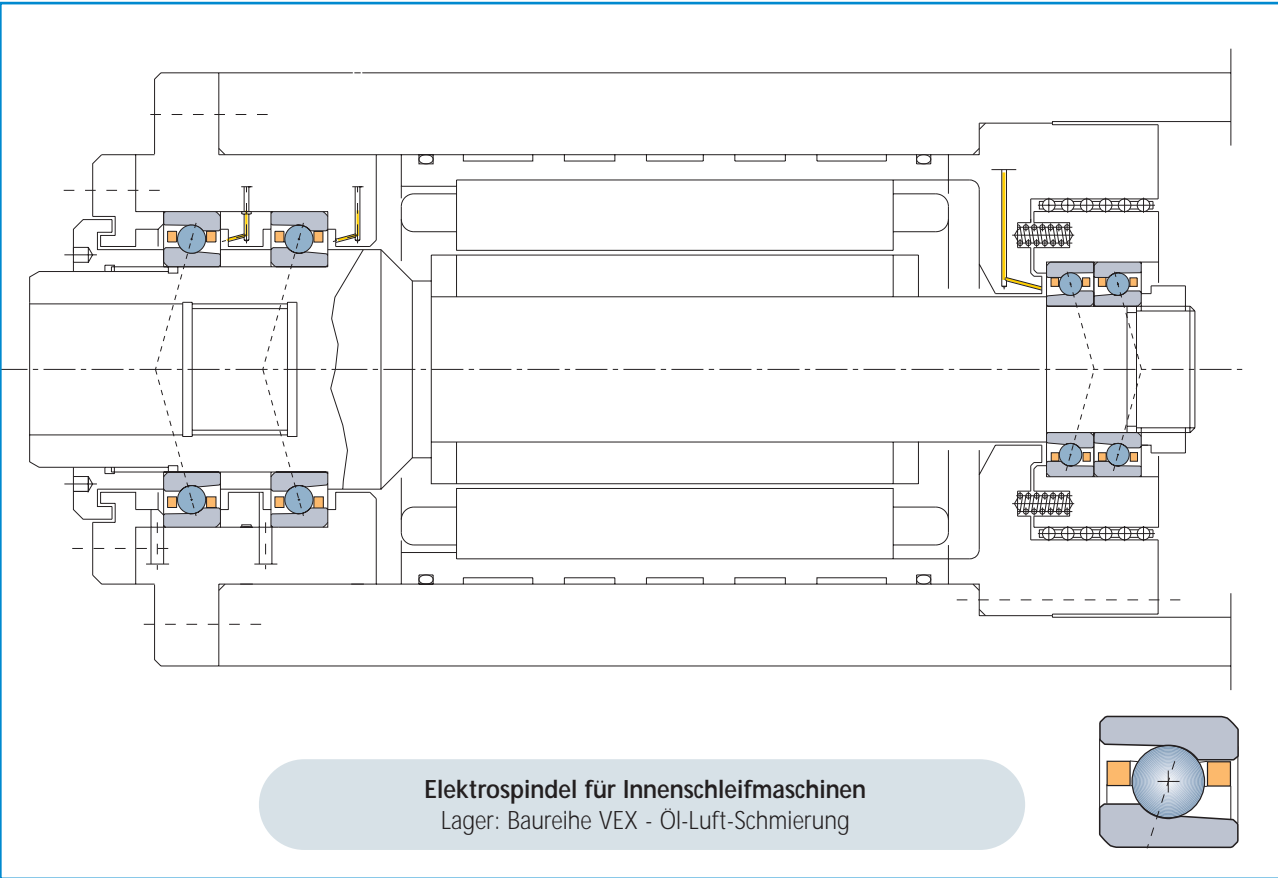
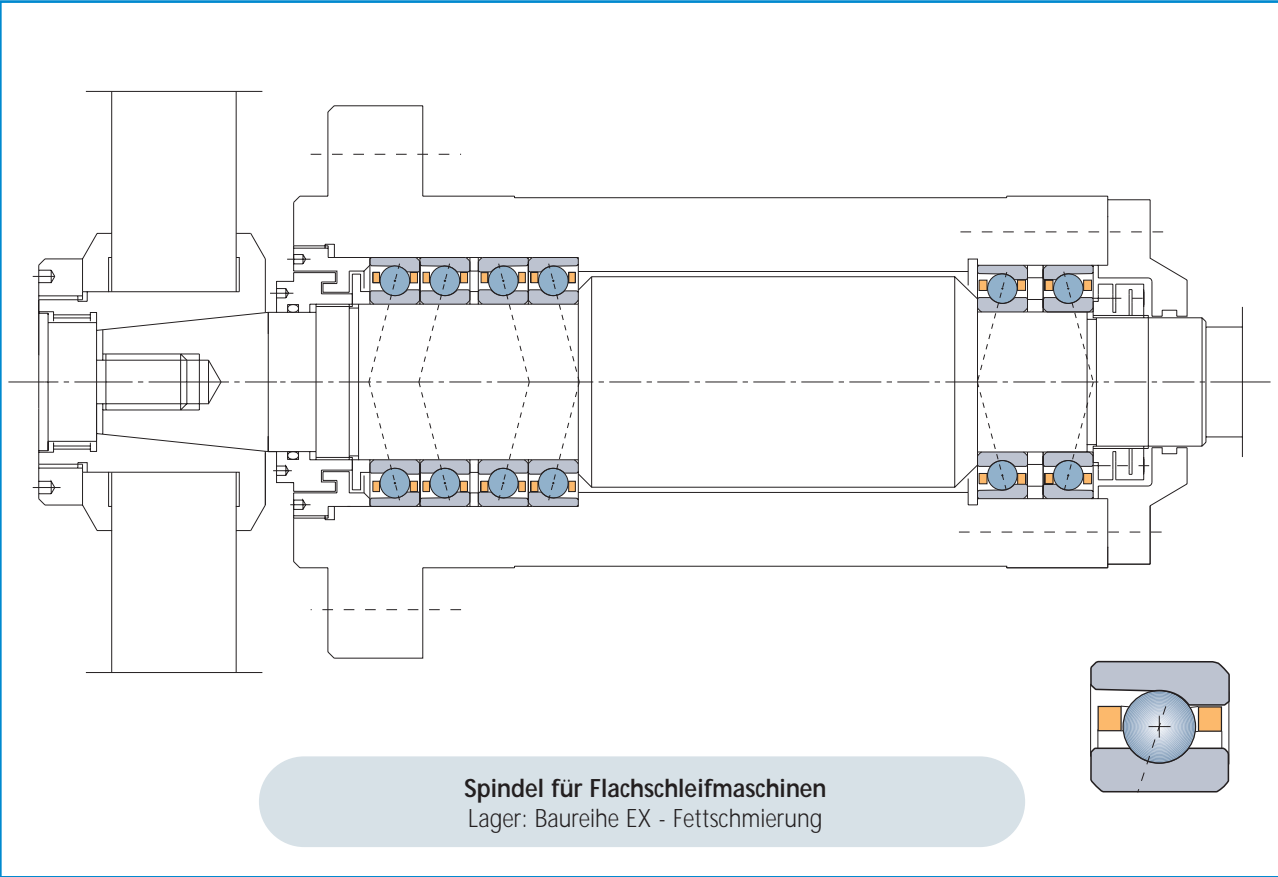

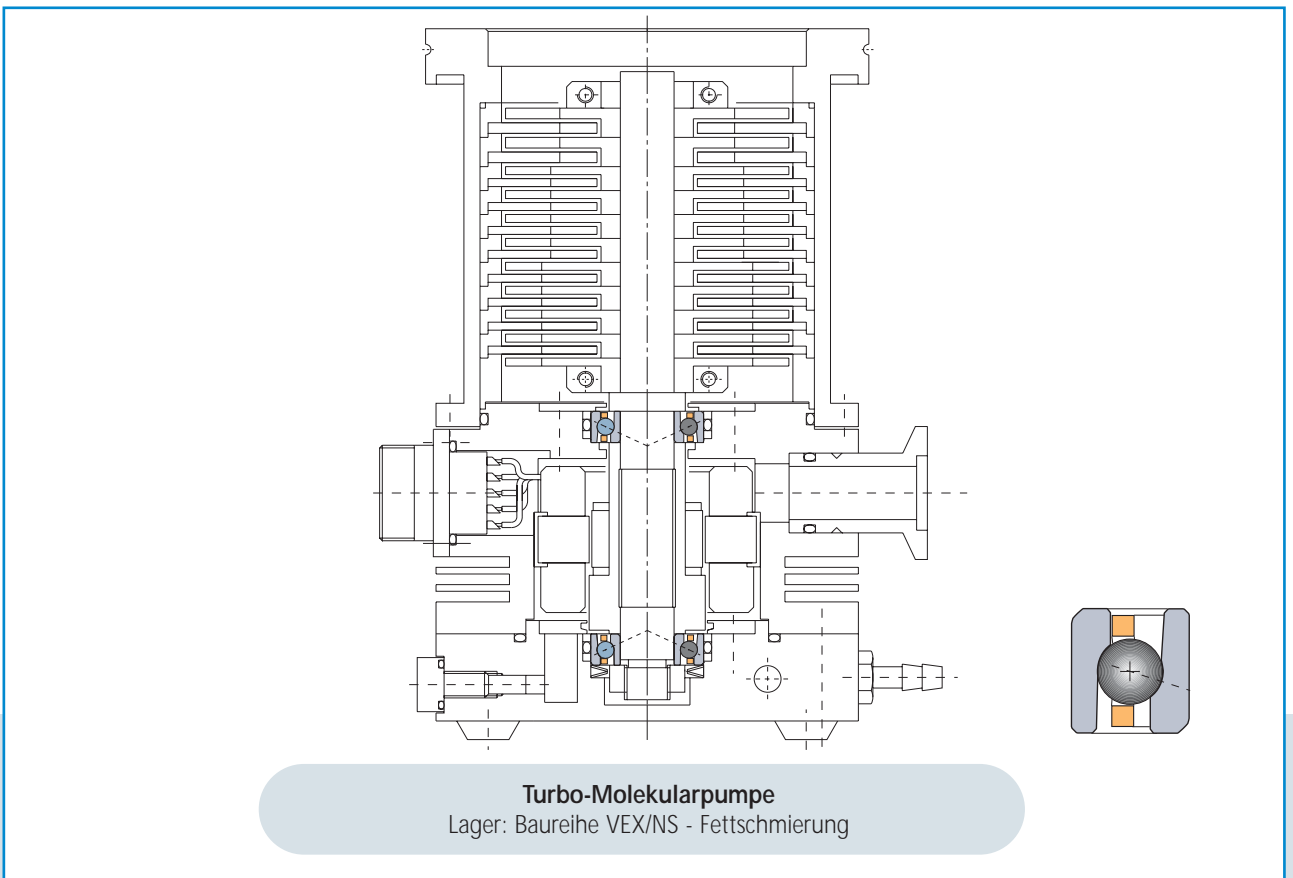
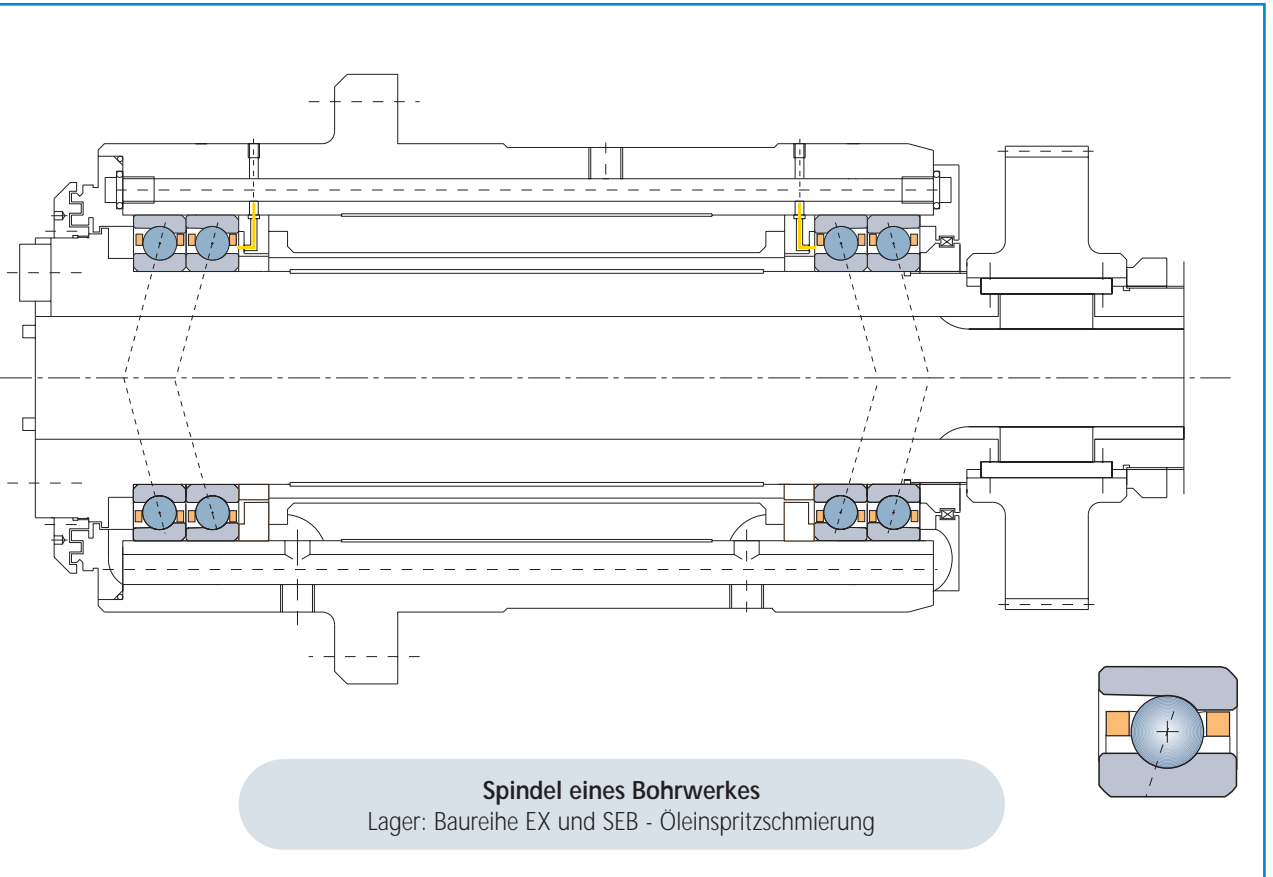

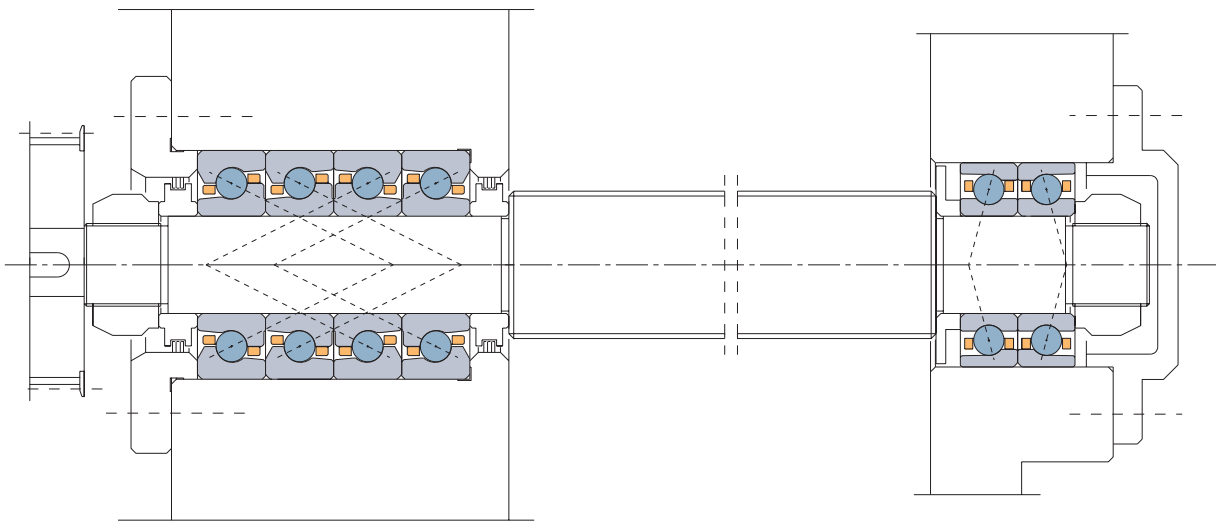

**Lagerung einer Kugelumlaufspindel**

Lager: Antriebsseite Baureihe BS 200  
 Loslagerseite Baureihe E 200

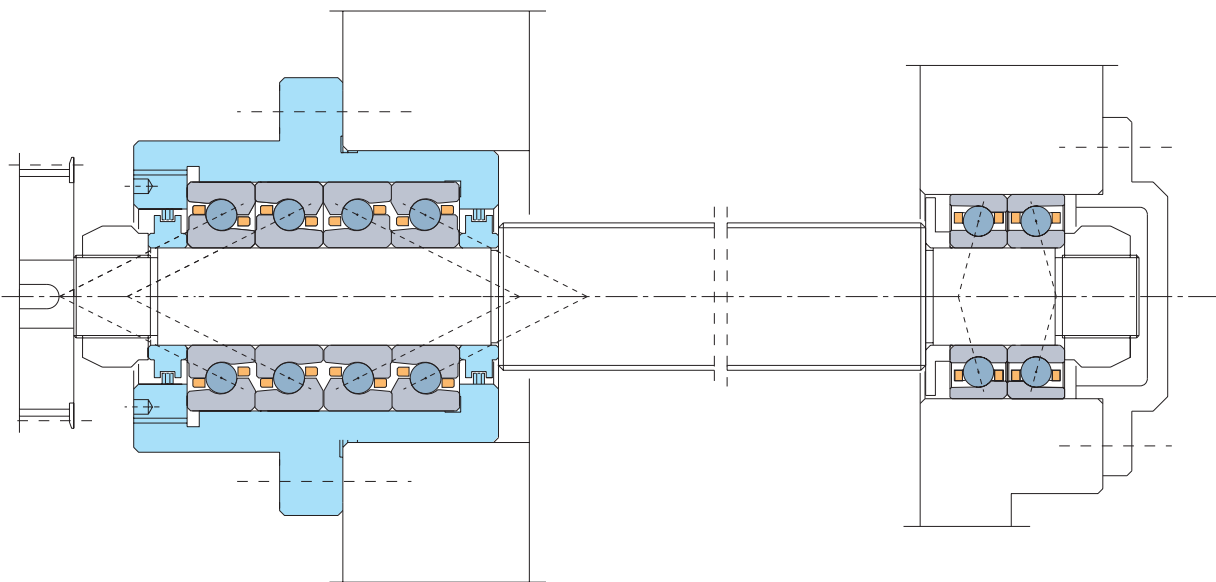
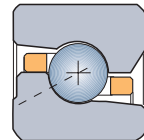

**Lagerung einer Kugelumlaufspindel**

Lager: Antriebsseite Gehäuseeinheit BSQU mit Lagern  
 Baureihe BS 200 - Loslagerseite Baureihe E 200

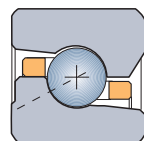

# Behandlung und Montage der Präzisions-Schrägkugellager

SNFA-Hochgenauigkeitslager werden in allen Produktionsphasen, einschliesslich der Konservierung und Verpackung, unter streng kontrollierten Bedingungen hergestellt.

Die Lagereigenschaften können nur dann vollständig ausgenutzt werden, wenn folgende Grundregeln für die Aufbewahrung und für die Montage beachtet werden:

- die Lager in der Originalverpackung aufbewahren (horizontal) und vor Feuchtigkeit schützen
- die Reihenfolge der Montage vorplanen
- die Montage sollte in einem staubfreien Raum erfolgen
- den Zustand der Anschlussteile einschließlich Abstandshülsen kontrollieren
- die Verpackungsbeschriftung mit den Angaben auf der Zeichnung vergleichen
- die Originalverpackung erst unmittelbar vor dem Einbau öffnen
- geeignete Montagewerkzeuge verwenden
- die Fettmenge festlegen und gleichmässig im Lager verteilen.  
Bei Verwendung von synthetischen Fetten sollten die Lager gespült werden (Reinbenzin), um den grössten Teil des Schutzöles zu entfernen.  
Die Lager frei trocknen lassen (keine Pressluft); sauberes Lösungsmittel verwenden.  
Die Lager im gereinigten Zustand nicht drehen.
- die Montageanweisung (einliegend in der Lagerschachtel) beachten (Montagekräfte nicht über die Lagerkugeln leiten)
- die Lager bei der Montage nicht verkanten, eventuell ist ein Anwärmen des Lagers notwendig.



# Axiale Befestigung der Lagerringe

Lagerringe werden axial mittels Muttern oder speziellen Lagerdeckeln (mit Schrauben) befestigt. Um eine wirksame Befestigung zu erreichen, müssen diese Elemente folgende Eigenschaften aufweisen:

- hohe Genauigkeit;
- gute mechanische Eigenschaften, speziell gute statische und dynamische Festigkeit;
- ein sicheres Blockiersystem, welches jedoch keine Deformation hervorruft.

Der wichtigste Faktor ist jedoch, sicher zu stellen, dass die richtigen axialen Zusammenspannkraften "Pa" eingeleitet werden. Die Zusammenspannkraft "Pa" muss folgenden, zum Teil widersprüchlichen Anforderungen gerecht werden:

- Sicherstellung, dass unter Einwirkung von Arbeitskräften die Vorspannung nicht ihre Wirkung verliert, bzw. keine Mikrobewegungen zwischen Welle und Innenring auftreten, welche sich als Überhitzungs- oder Kontaktkorrosionsschäden bemerkbar machen;
- Verhinderung zu grosser Deformation der montierten Elemente und damit auftretende Laufprobleme (Variation der Vorspannung aufgrund der Zwischenringdeformation oder Deformation der Lagerlaufbahn).
- Verringerung der Materialermüdung;

Eine präzise Festlegung des optimalen "Pa"-Wertes unter Berücksichtigung der oben erwähnten Anforderungen ist nicht einfach, da verschiedene Faktoren nicht genau bekannt sind.

Mittels folgender Berechnungsformel lässt sich jedoch ein in der Praxis bewährter "Pa"-Wert errechnen:

## Berechnung der axialen Zusammenspannkraft "Pa"

$$Pa = Fs + (N_{cp} \cdot Fc) + Pr$$

wobei:

<b>Pa</b>	Axiale Zusammenspannkraft (daN)
<b>Fs</b>	Minimale axiale Zusammenspannkraft (daN)
<b>Fc</b>	Axiale Montagekraft (daN)
<b>Pr</b>	Lagervorspannung (daN)
<b>Ncp</b>	Anzahl der vorgespannten Lager

Die "Fs"- und "Fc"-Werte können gemäss folgender Seiten (in Abhängigkeit der Lagerserie und des Bohrungsdurchmessers) ermittelt werden.

Die Standardwerte der Lagervorspannung (leicht - mittel - stark) sind im Hauptkatalog ersichtlich.

Spezielle Vorspannungen werden durch die Lagerbezeichnung definiert, z.B.: SEB 60 7CE 1 DD 96 daN.

Bei geringer Belastung der Spindeln kann der Wert "Fs" reduziert werden (0,8:Fs).

## Berechnung des Anzugsmomentes "C"

Mit den "Pa" - Werten kann das Anzugsmoment "C" (daN · mm) wie folgt berechnet werden:

$C = K \cdot Pa$	für Wellenmuttern
$C = K \cdot Pa / Nb$	für Lagerdeckeln mit Schrauben

K = Faktor in Abhängigkeit des Gewindes, siehe Tabelle Seite xx.

Nb = Anzahl der Schrauben im Lagerdeckel..

**Achtung:** die berechneten Anzugsmomente sind gültig für:

A) SNFA-Lager montiert gemäss SNFA-Toleranzen, siehe Kapitel Toleranzen;

B) Lager und Distanzringe (ohne Zahnräder und andere Elemente);

C) Max. axiale Bearbeitungskräfte kleiner 2 Pa;

D) Wellenmuttern und Schrauben hoher Qualität mit leicht geöltem Gewinde.

Bei Abweichungen bzw. bei speziellen Anwendungsfällen stehen Ihnen die SNFA-Verkaufs- und Beratungsingenieure gerne zur Verfügung.

# Berechnung der axialen Zusammenspannkraft

d	SERIE SEA		SERIE SEB - VEB - HB		SERIE VEX - EX		SERIE E 200		SERIE BS 200 - BS (SPEZIAL)	
	F <sub>s</sub>	F <sub>c</sub>	F <sub>s</sub>	F <sub>c</sub>	F <sub>s</sub>	F <sub>c</sub>	F <sub>s</sub>	F <sub>c</sub>	F <sub>s</sub>	F <sub>c</sub>
6					26	43				
7					31	41				
8			33	28	45	49	49	55		
9					60	49	65	60		
10	37	24	50	28	65	55	85	70		
12	43	21	60	28	70	47	100	70	120	75
15	55	18	65	28	100	49	95	60	140	75
17	60	16	75	28	100	49	130	70	190	80
20	95	25	130	40	160	65	230	85	260	95
25	120	21	160	34	180	50	240	75	320	95
30	140	18	190	30	250	55	340	80	480	95
35	160	21	260	44	330	75	550	120	650	130
40	180	18	310	50	410	75	600	120	800	140
45	240	19	380	48	450	75	700	120	900	130
50	290	18	310	38	500	65	600	100	1 000	130
55	330	23	410	43	600	80	750	110		
60	330	24	450	40	650	75	1 100	130	1 500	150
65	470	26	480	37	700	70	1 300	130		
70	500	24	650	50	850	80	1 400	130		
75	550	23	650	48	900	75	1 500	130	2 100	210
80	550	30	700	65	1 100	120	1 700	190		
85	750	55	900	90	1 100	140	1 900	250		
90	800	50	950	85	1 600	170	1 900	250		
95	800	48	1 000	85	1 400	150	2 700	300		
100	850	46	1 200	100	1 500	140	2 700	310		
105	900	45			1 700	160	3 100	330		
110	1100	60	1 300	90	2 000	180	3 700	360		
120	1200	60	1 600	120	2 200	190	4 500	430		
130	1700	90	2 300	160	2 700	270	4 800	450		
140	1600	80	2 400	150	2 900	250	5 900	500		
150	2100	100	2 700	180	3 400	270				
160			2 800	170	3 800	290				
170			3 000	160	5 100	350				
180			3 700	220	6 400	450				
190			3 900	260	6 800	500				
200			4 800	320	6 600	550				
220			5 200	290	7 900	600				
230			5 500	280						
240			5 700	270	8 600	550				
260			7 700	400						
280			8 300	400						

## Mittels Wellenmuttern

- Anziehen der Mutter mit dem 2 - 3 fachen des berechneten Anzugsmomentes "C".
- Lösen der Wellenmutter mit anschliessendem Anziehen bis zum berechneten Anzugsmoment "C".
- Blockieren der Mutter entsprechend den Angaben des Mutterlieferanten.

## Mittels Lagerdeckel und Schrauben

Die Lagerdeckelnase, welche gegen den Lagerring drückt, muss so lang sein, dass die Schulter unter Einwirkung der axialen Befestigungskraft keinen Kontakt mit dem Gehäuse hat, d.h. die Länge "L", (Zeichnung) muss grösser als Null sein.

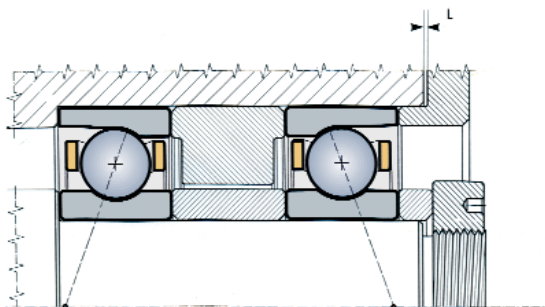

- Anziehen aller Schrauben (über Kreuz) mit dem 2-3 fachen des berechneten Anzugsmomentes "C";
- Lösen der Schrauben mit anschliessendem Anziehen bis zum berechneten Anzugsmoment "C" (Anziehen über Kreuz);
- Messung des Abstandes "L" zwischen Lagerdeckel und Gehäuse;
- Verkürzen der Nase (oder Verwendung einer Präzisionsunterlegscheibe) um den Betrag des gemessenen Abstandes "L";
- Langsames Anziehen der Schrauben bis zum berechneten Anzugsmoment "C" (an-ziehen über Kreuz).

## Wichtiger Hinweis

Die somit angepasste Länge der Lagerdeckelnase ist nur gültig für den verwendeten Lagersatz. Sollte der Lagersatz gewechselt werden, ist eine erneute Anpassung erforderlich.

## Zwischenringe

Zwischenringe, mit der gezeigten Form, haben Betriebsvorteile für geneigten oder vertikalen Einsatz und gewährleisten eine eventuell erforderliche Fettreserve.

## Koeffizient "K" für die Berechnung des Anzugsmomentes

GEWINDE	FAKTOR "K"		GEWINDE	FAKTOR "K"
	MUTTER	SCHRAUBE		
M 4		0.8	M 70	9.0
M 5		1.0	M 75	9.6
M 6		1.2	M 80	10.0
M 8		1.6	M 85	11.0
M 10	1.4	2.0	M 90	11.0
M 12	1.6	2.4	M 95	12.0
M 14	1.9	2.7	M 100	12.0
M 15	2.0	2.9	M 105	13.0
M 16	2.1	3.1	M 110	14.0
M 17	2.2		M 120	15.0
M 20	2.6		M 130	16.0
M 25	3.2		M 140	17.0
M 30	3.9		M 150	18.0
M 35	4.5		M 160	19.0
M 40	5.1		M 170	21.0
M 45	5.8		M 180	22.0
M 50	6.4		M 190	23.0
M 55	7.0		M 200	24.0
M 60	7.6		M 220 - 230	26.0
M 65	8.1		M 240	27.0
			M 260	29.0
			M 280	32.0

Bemerkung: Die Werte "K" der Tabelle sind gültig für Feingewinde.

## Vergleichstabelle der Bezeichnungen von Präzisions-Schrägkugellagern anderer Fabrikate

Die nachstehende Vergleichstabelle dient lediglich zur Information und ist bezüglich technischer Merkmale und Resultate nicht bindend.

SERIEN	SNFA	FAG BARDEN	FAFNIR	GMN	NSK	RHP	SKF	SNR	
ISO 18	SEA							71800	
ISO 19	SEB	B 71900	1900 H	9300 WI	S 61900	7900	7900	71900	71900
ISO 19 *	VEB HB	HS 71900		99300 WN		BNC 19	S 7900	71900 CE	
ISO 10	EX	B 7000	100 H	9100 WI	S 6000	7000	7000	7000	7000
ISO 10 *	VEX	HS 7000		99100 WN	SH 6000	BNC 10	S 7000	7000 CC 7000 CE	
ISO 02	E 200	B 7200	200 H	200 WI	S 6200	7200	7200	7200	7200
ISO 02	BS 200	76020						BSA 2	

\* = Hohe Geschwindigkeit



Zusätzliche Informationen über SNFA® Spindellager und deren Anwendungen finden Sie in nachstehenden Publikationen.



SNFA® Produktübersicht



SNFA® Montagehinweise/Schadensanalyse



SNFA® Berechnungsprogramm **SECBA**

*(SNFA® Electronic Consultant for Bearing Applications)*

Der Inhalt dieser Broschüre ist ausschliesslich Eigentum der SNFA. Nachdruck, auch auszugsweise, bedarf unserer ausdrücklichen Genehmigung. Mit diesem Katalog wollen wir die grösstmögliche Unterstützung bieten. Alle Angaben wurden sorgfältig erstellt und überprüft. Für eventuelle Fehler oder Unvollständigkeiten können wir jedoch keine Haftung übernehmen. Die Darstellungen entsprechen nicht unbedingt dem tatsächlichen Produkt. Änderungen, die dem technischen Fortschritt dienen, sind vorbehalten.

**SNFA S.A.S.**

Zone Industrielle No 2 - Batterie 900 - 59309 VALENCIENNES CEDEX - F  
Tél. +33-(0)327235212 - Fax +33-(0)327235297  
[www.snfa.com](http://www.snfa.com) - e-mail: [info@snfa.com](mailto:info@snfa.com)

**SNFA Bearings Ltd**

Wotton Road Charfield Wotton-under-Edge  
Gloucestershire GL 12 8 SP - UK  
Tel. +44-(0)1453 843501 - Fax +44-(0)1453 842577  
[www.snfa.com](http://www.snfa.com) - e-mail: [sales@snfa-bearings.co.uk](mailto:sales@snfa-bearings.co.uk)

**SNFA G.m.b.H.**

Ringstrasse 134 - D - 70839 Gerlingen  
Tel. +49-(0)7156 20450 - Fax +49-(0)7156 204550  
[www.snfa.com](http://www.snfa.com) - e-mail: [snfa@snfa.de](mailto:snfa@snfa.de)

**SNFA S.A., Fribourg**

Route du Platy 5a, P.O. Box 34 - CH-1752 Villars-Sur-Glâne 1  
Phone +41-(0)26 4097146 - Fax +41-(0)26 4020614  
[www.snfa.com](http://www.snfa.com) - e-mail: [info@snfa.ch](mailto:info@snfa.ch)

**SOMECAT S.p.A.**

Via Savonera-Druento 15 - 10044 PIANEZZA (TO) - Italy  
Tel. +39-011 9941407 (r.a.) - Fax +39-011 9845804  
[www.snfa.com](http://www.snfa.com) - e-mail: [info@somecat.com](mailto:info@somecat.com)