

2. iglidur®

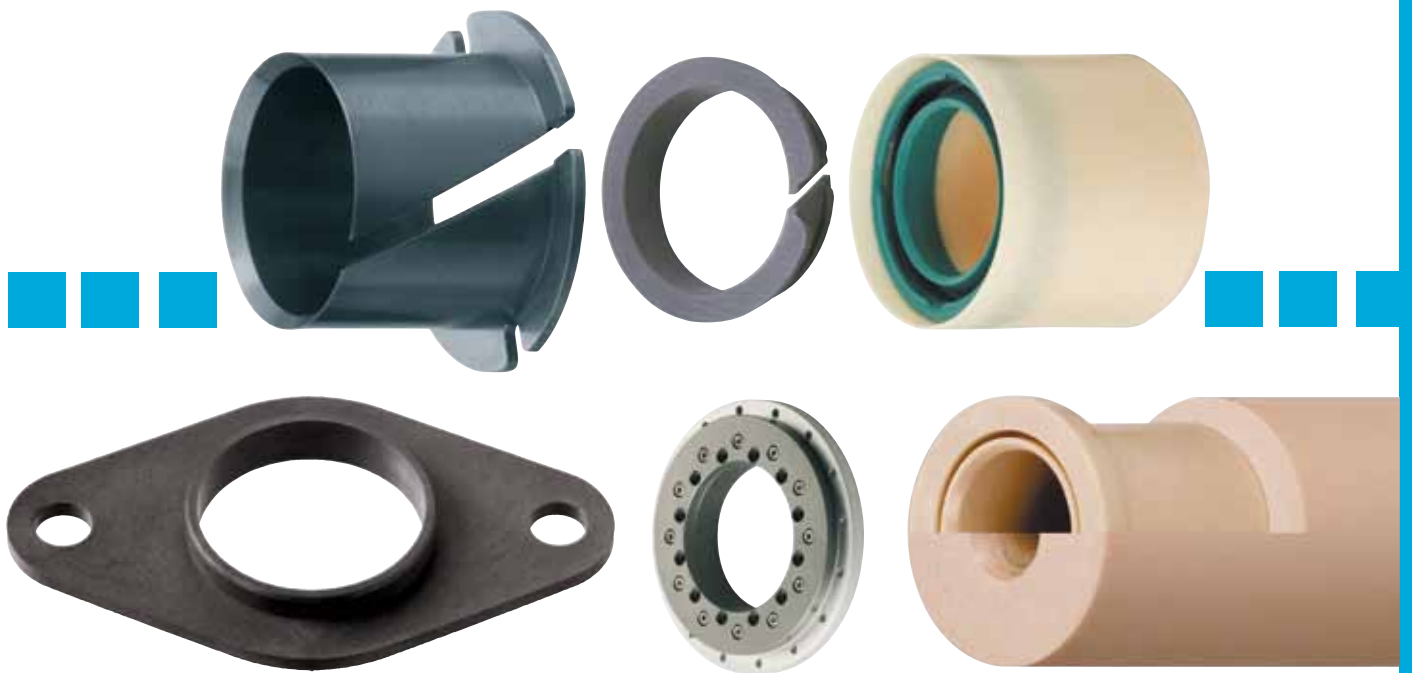

Additional products: clip & slewing ring bearings, stock bars and much more ...

...plastics

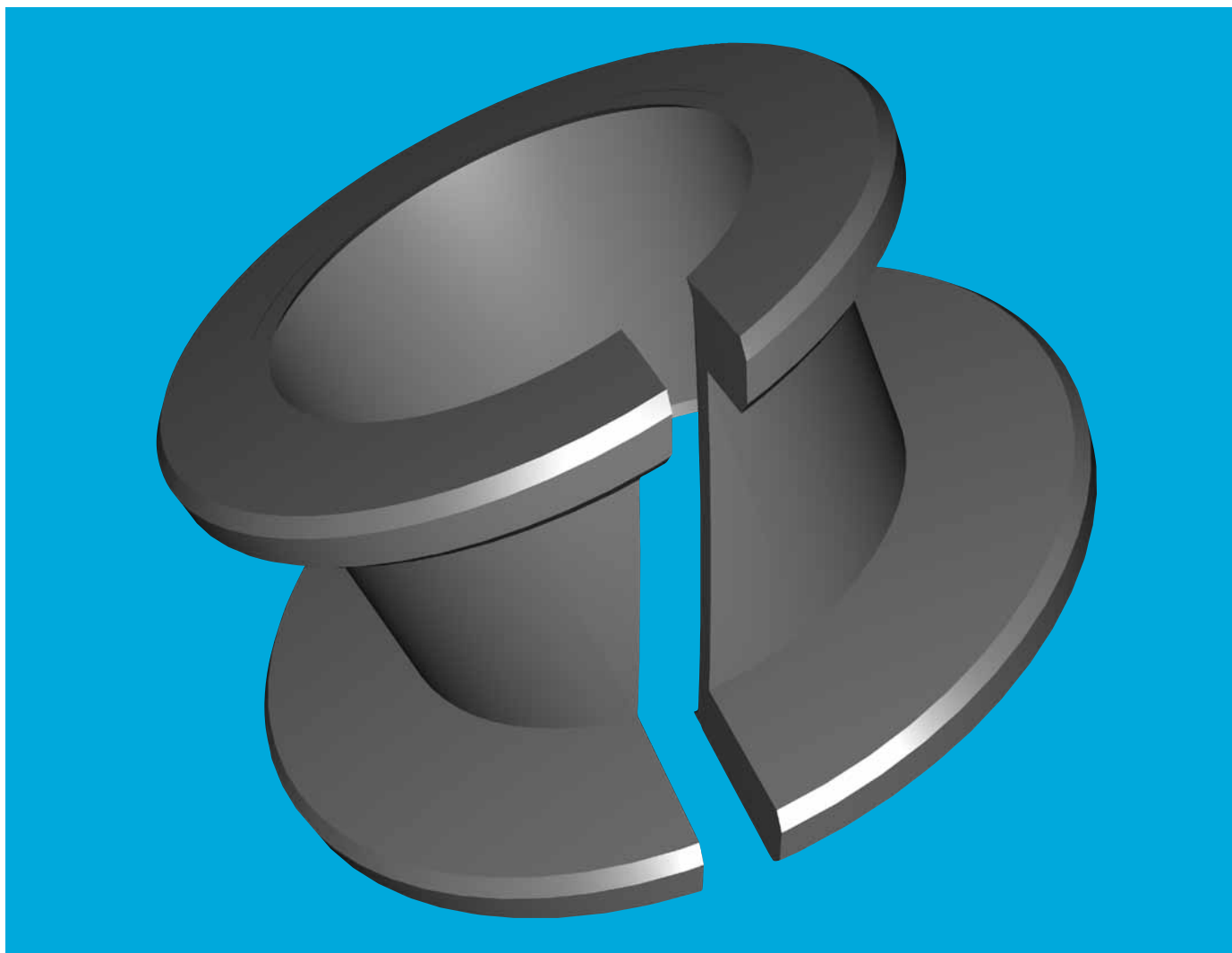

iglidur® Clip Bearings



Standard range from stock

Easy to fit

Increased security with the double flange design

Good wear resistance

Maintenance-free and predictable lifetime

Material iglidur® M250

Special dimensions are possible

iglidur® Clip Bearings

iglidur® clip bearings are designed specifically for putting shafts through sheet metal. For this reason, the bearings have flanges located on both ends. The bearings are secured in the sheet metal plate on both sides after fitting.

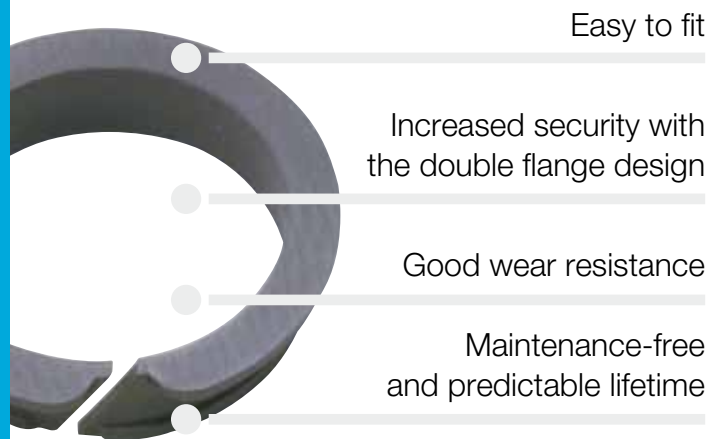

When to use it?

- When a sheet metal bearing is required
- When the bearing should be fitted into a drilled or punched hole with a wide tolerance
- For rotating, linear and pivoting movements
- When a quick-fitting bearing solution is sought



When not to use it?

- When continuous temperatures of above +80 °C occur
 - ▶ iglidur® G, page 61
- When a high-precision bearing is needed
 - ▶ iglidur® J, page 89
- When the sheet metal is more than 4 mm thick
 - ▶ iglidur® Clips2, page 509
 - ▶ iglidur® MKM, page 513
- When extremely high surface pressures occur
 - ▶ iglidur® G, page 61

Temperature

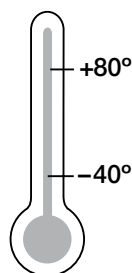

Product range

1 style
 Ø 3–12 mm
 more dimensions
 on request



iglidur® Clip Bearings | Technical Data

Main Criteria

iglidur® clip bearings are designed specifically for putting shafts through sheet metal. For this reason, the bearings have flanges located on both ends. The bearings are secured in the sheet metal plate on both sides after fitting. The clip bearings have an angled slot which allows the bearings to be fitted from one side. After fitting, the bearing expands and forms a lining for the bore in the metal plate. The shaft prevents the clip bearing from falling out the housing. Even during linear movement, the bearing cannot slide out of the housing. In addition, the lateral slot can compensate for bearing expansions due to temperature or moisture. During expansion, the slot width decreases, and changes to the bearing clearance are minimized. The flange diameter on the smaller side is made in such a way that housings with larger tolerances still provide sufficient security. iglidur® clip bearings are made of a plain bearing materials which gives strong wear resistance at average loads. The bearings are selflubricating and are designed to be used dry. If required, the bearings can be lubricated, as iglidur® M250 is resistant to all common lubricants.

Mechanical Properties

The permissible static pressure of iglidur® clip bearings at room temperature is 20 MPa. Due to the possibility of high tolerances in the housing bore, the clip bearing has a high compressive strength even for punched holes. For bearing surfaces that are very small, the vibration dampening properties and the resistance to edge loads are especially important.

► iglidur® M250, page 107

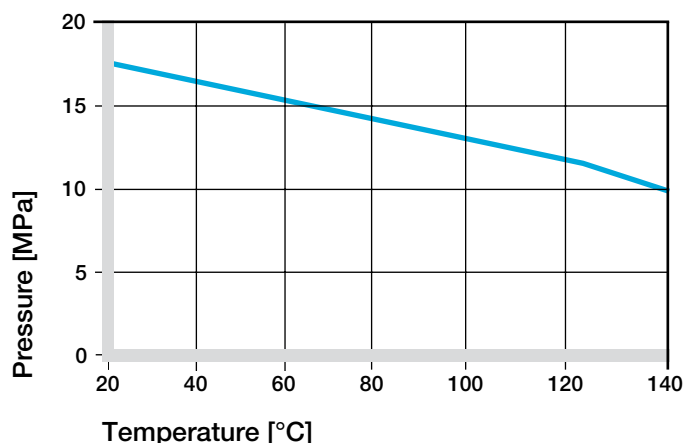

Graph 02: Recommended maximum surface pressure as a function of temperature (20 MPa at +20 °C)

Permissible Surface Speeds

Clip bearings are extremely wear resistant in slow rotating, oscillating, and linear movements. The maximum surface speeds for the different movements are the same as for the material iglidur® M250 (Table 02).

With lubrication the permissible speeds can be increased.

► Surface Speed, page 45

m/s	Rotating	Oscillating	Linear
Continuous	0.8	0.8	2.5
Short term	2	2	5

Table 02: Maximum running speed

Temperatures

For operating temperatures up to +80 °C iglidur® clip bearings display high wear resistance. Even in the cold, the plain bearings remain elastic and resistant to wear.

► Application Temperatures, page 46

iglidur® M250	Application temperature
Minimum	-40 °C
Max. long term	+80 °C
Max. short term	+170 °C

Table 03: Temperature limits

Installation

For installation, the plain bearings are pressed together on the side with the large flange. The angled slot makes the bearing spiral shaped so that it can be placed easily into the metal plate. The slot also compensates for expansions of the circumference. In this way, a tight clearance is possible with the clip bearings.

The recommended clearance allows a nominal size shaft to turn easily. The clip bearings should be fitted into a housing with a "H" class tolerance, up to H13. The clip bearing can also rotate within the housing bore.

Clip Bearings

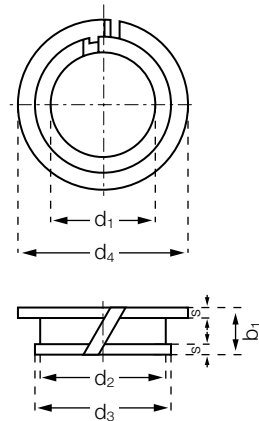

Order key

MCM-06-015

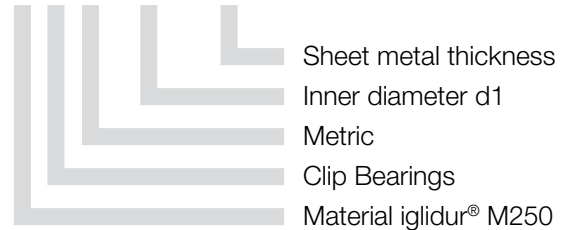

Material:

iglidur® M250 ► page 107

Dimensions [mm]

Part number	d1	d2	d3	d4	s	b1
	D11*				-0.10	+0.20
MCM-06-015	6	7.2	7.8	11	0.6	3.2
MCM-03-02	3	4.2	4.8	6	0.6	3.2
MCM-04-02	4	5.2	5.9	7	0.6	3.2
MCM-05-02	5	6.2	6.8	8	0.6	3.2
MCM-06-02	6	7.2	7.8	11	0.6	3.2
MCM-08-02	8	9.6	10.4	13	0.8	3.6
MCM-09-02	9	10.6	11.4	14	0.8	3.6
MCM-10-02	10	11.6	12.4	15	0.8	3.6
MCM-10-025	10	11.6	12.4	15	0.8	4.1
MCM-12-02	12	13.6	14.4	17	0.8	3.6
MCM-16-02	16	17.6	18.4	21	0.8	3.6
MCM-03-03	3	4.2	4.8	6	0.6	4.2
MCM-04-03	4	5.2	5.9	7	0.6	4.2
MCM-05-03	5	6.2	6.8	8	0.6	4.2

Part number	d1	d2	d3	d4	s	b1
	D11*				-0.10	+0.20
MCM-06-03	6	7.2	7.8	11	0.6	4.2
MCM-07-03	7	9	9.8	13	0.8	4.6
MCM-08-03	8	9.6	10.4	13	0.8	4.6
MCM-10-03	10	11.6	12.4	15	0.8	4.6
MCM-12-03	12	13.6	14.4	17	0.8	4.6
MCM-14-03	14	15.6	16.4	19	0.8	4.6
MCM-16-03	16	17.6	18.4	21	0.8	4.6
MCM-18-03	18	20	21	23	1.0	5.0
MCM-20-03	20	22	23	25	1.0	5.0
MCM-25-03	25	27	28	30	1.0	5.0
MCM-12-035	12	13.6	14.4	17	0.8	5.1
MCM-06-04	6	7.2	7.8	11	0.6	5.2
MCM-12-04	12	13.6	14.4	17	0.8	5.6
MCM-10-08	10	11.6	12.4	15	0.8	9.6

* d1 measurement is measured with a plug gauge after fitting into a reference housing d2 (+0.005)



delivery available
time from stock



prices price list online
www.igus.co.uk/en/clips



order part number
example MCM-06-015

iglidur® Clip Bearings | Product Range | Inch

Clip Bearings

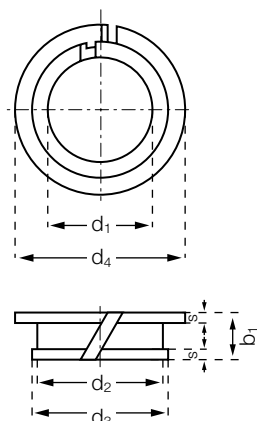

Order key

MCI-03-01



Material:

iglidur® M250 ► page 107

Dimensions [Inch]

Part number	d1 D11*	d2	d3	d4	s -0.10	b1 + 0.20
MCI-03-01	3/16	0.2343	1/4	5/16	0.032	0.1380
MCI-04-01	1/4	0.3125	11/32	7/16	0.032	0.1380
MCI-05-01	5/16	0.3750	13/32	1/2	0.032	0.1380
MCI-06-01	3/8	0.4375	15/32	9/16	0.032	0.1380
MCI-07-01	7/16	0.5000	17/32	5/8	0.032	0.1380
MCI-08-01	1/2	0.5625	19/32	11/16	0.032	0.1380
MCI-03-02	3/16	0.2343	1/4	5/16	0.032	0.2000
MCI-04-02	1/4	0.3125	11/32	7/16	0.032	0.2000
MCI-05-02	5/16	0.3750	13/32	1/2	0.032	0.2000
MCI-06-02	3/8	0.4375	15/32	9/16	0.032	0.2000
MCI-07-02	7/16	0.5000	17/32	5/8	0.032	0.2000
MCI-08-02	1/2	0.5625	19/32	11/16	0.032	0.2000

* d1 measurement is measured with a plug gauge after fitting into a reference housing d2 (+0.005)



delivery available
time from stock



prices price list online
www.igus.co.uk/en/clips



order part number
example MCI-03-01

My Sketches

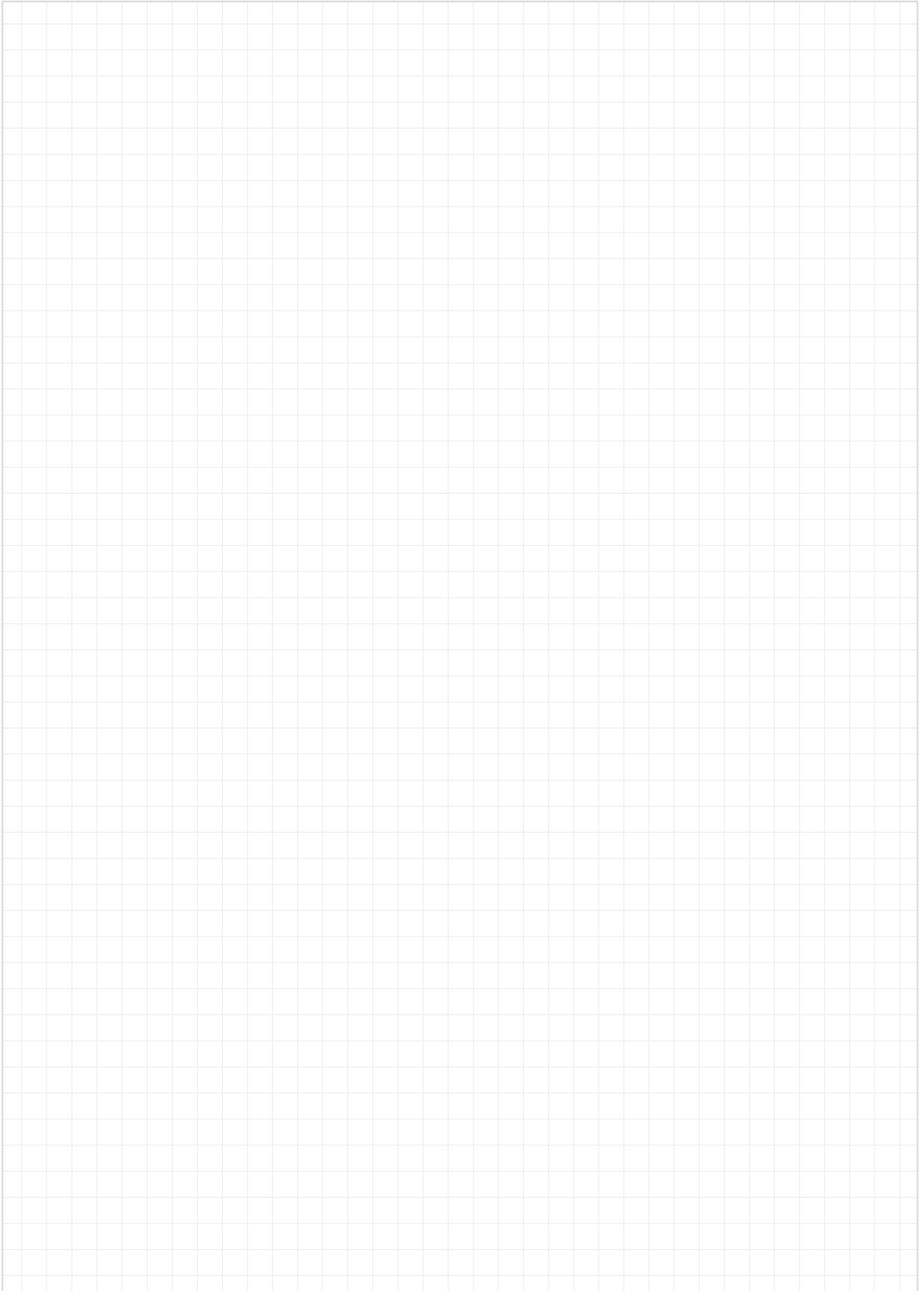

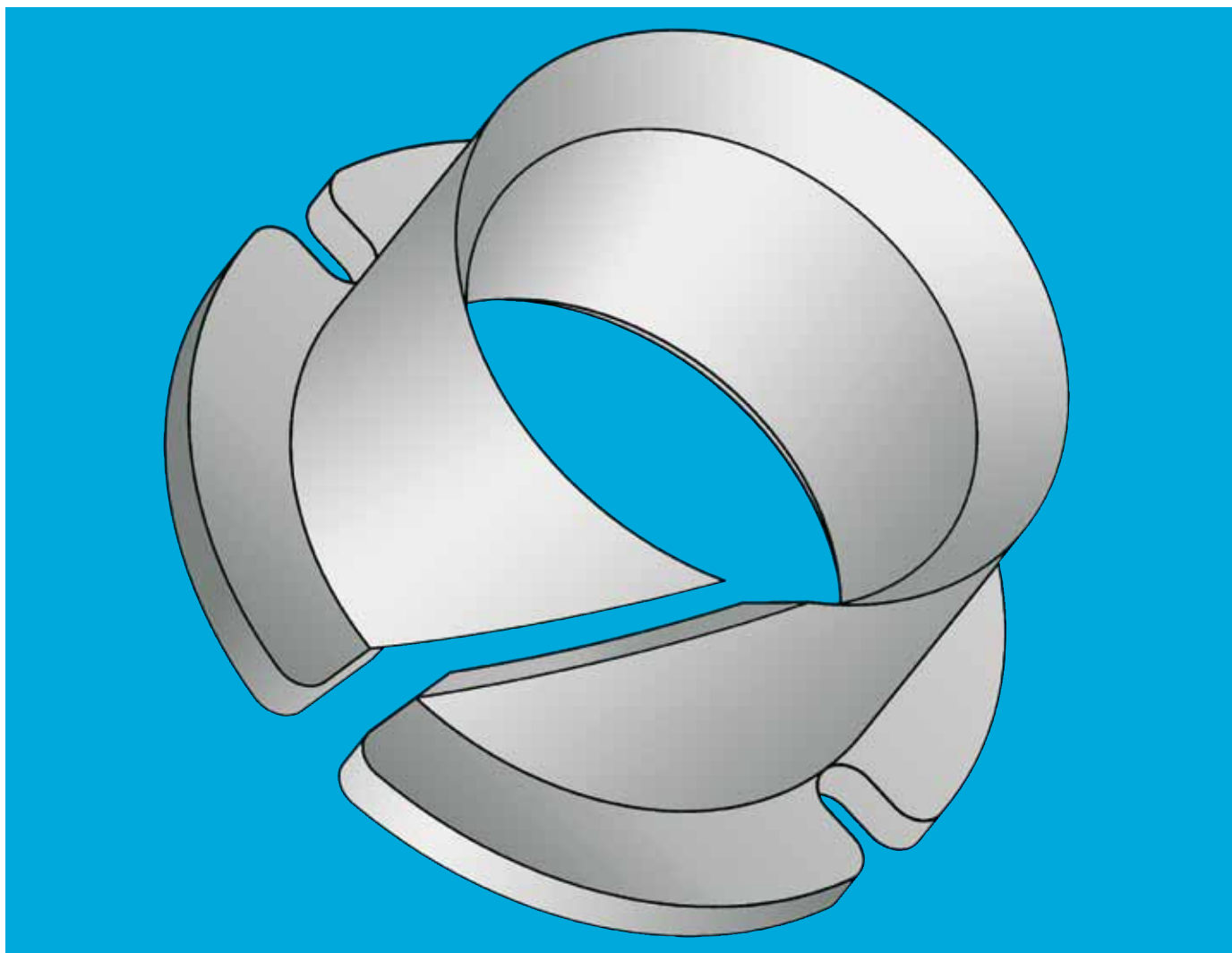

iglidur® Clips2 – easy assembly due to angle slot



Available from stock

Low bearing clearance, high precision

Easy installation due to chamfered edge

Material: iglidur® M250

Maintenance-free and predictable service life

iglidur® Clips2

Easy assembly due to angle slot. These iglidur® M250 self lubricating plain bearings give impact strength, vibration dampening, and wear resistant properties. The bearings are designed for use in applications which vibration dampening is necessary, for example, in fitness and packaging machines.

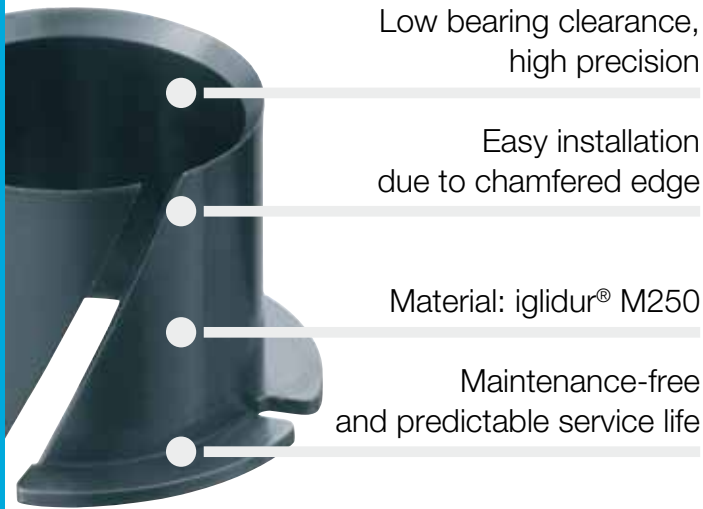

Low bearing clearance,
high precision

Easy installation
due to chamfered edge

Material: iglidur® M250

Maintenance-free
and predictable service life



When to use it?

- When a simple assembly (by hand) is required
- When there is a very imprecise housing bore
- When a simple and cost effective bearing solution is sought



When not to use it?

- When the bearing should be secured by press fit
▶ **iglidur® M250, page 107**
- When continuous temperatures of above +80° C occur
▶ **iglidur® G, page 61**
- When extremely high surface pressures occur
▶ **iglidur® G, page 61**

Temperature

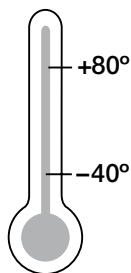

Product range

1 style
Ø 4–25 mm
more dimensions
on request



igidur® Clips2 | Product Range

Clips2

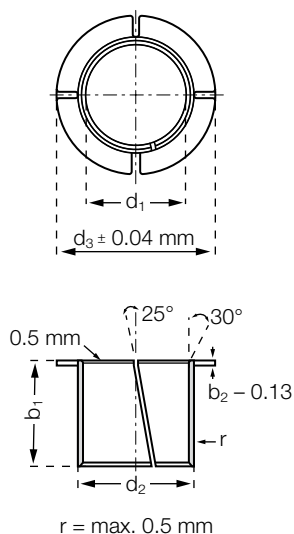

Order key

MYM-04-04

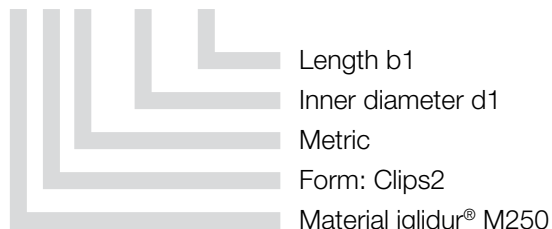

Material:

igidur® M250 ► page 107

Dimensions [mm]

Part number	d1	d1-Tolerance*	d2**	d3 ±0.40	b1 -0.40	b2 -0.13
MYM-04-04	4	+0.025/+0.075	5.20	7.00	4.00	0.60
MYM-05-05	5	+0.025/+0.075	6.20	8.00	5.00	0.60
MYM-06-06	6	+0.025/+0.075	7.20	9.50	6.00	0.60
MYM-08-08	8	+0.025/+0.075	9.60	12.00	8.00	0.80
MYM-10-10	10	+0.025/+0.075	11.60	15.00	10.00	0.80
MYM-12-12	12	+0.025/+0.075	13.60	18.00	12.00	0.80
MYM-14-14	14	+0.025/+0.075	15.60	21.00	14.00	0.80
MYM-16-16	16	+0.025/+0.075	17.60	24.00	16.00	0.80
MYM-20-20	20	+0.025/+0.075	21.60	30.00	20.00	0.80
MYM-25-25	25	+0.025/+0.075	27.40	37.50	25.00	1.20

* d1 measurement is measured with a plug gauge after fitting into a reference housing d2 (+0.005)

** Recommended housing bore tolerance: H9



delivery available
time from stock



prices price list online
www.igus.co.uk/en/clips2



order part number
example MYM-04-04

Clips2

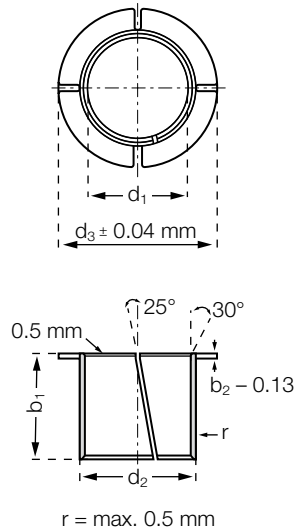

Order key

MYI-04-04

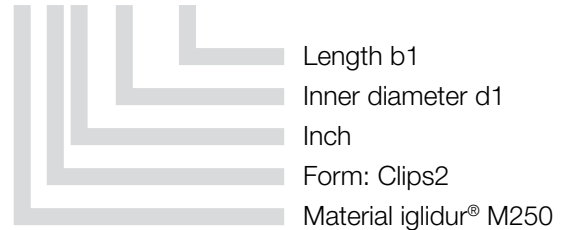

Material:
iglidur® M250 ► page 107

Dimensions [Inch]

Part number	d1	Shaft diameter		d2	Housing bore		d3	b1	b1- Tolerance	b2
		min.	max.		min.	max.				
MYI-03-03	3/16	.1875	.1865	0.2339	.2351	.2339	19/61	3/16	-0.016	0.0252
MYI-04-04	1/4	.0025	.2490	0.2965	.2979	.2965	13/32	1/4	-0.016	0.0252
MYI-05-05	5/16	.3125	.3115	0.3744	.3758	.3744	1/2	5/16	-0.017	0.0299
MYI-06-06	3/8	.3750	.3740	0.4370	.4387	.4370	19/32	3/8	-0.017	0.0299
MYI-07-07	7/16	.4375	.4365	0.4996	.5013	.4996	21/32	7/16	-0.017	0.0299
MYI-08-06	1/2	.5000	.4990	0.5618	.5635	.5618	3/8	3/4	-0.018	0.0299
MYI-08-08	1/2	.5000	.4990	0.5618	.5635	.5618	3/4	1/2	-0.018	0.0299
MYI-10-07	5/8	.6250	.6240	0.6870	.6887	.6870	15/16	7/16	-0.018	0.0299
MYI-10-10	5/8	.6250	.6240	0.6870	.6887	.6870	15/16	5/8	-0.018	0.0299
MYI-10-18	5/8	.6250	.6240	0.6870	.6887	.6870	15/16	1 1/8	-0.018	0.0299
MYI-12-12	3/4	.7500	.7490	0.8118	.8139	.8118	1 1/8	3/4	-0.019	0.0299
MYI-12-18	3/4	.7500	.7490	0.8118	.8139	.8118	1 1/8	1 1/8	-0.019	0.0299
MYI-14-7.5	7/8	.8750	.8740	0.9370	.9391	.9370	1 5/16	15/32	-0.019	0.0299
MYI-14-14	7/8	.8750	.8740	0.9370	.9391	.9370	1 5/16	7/8	-0.019	0.0299
MYI-16-14	1	1.0000	.9985	1.0933	1.0954	1.0933	1 1/2	7/8	-0.020	0.0449
MYI-16-16	1	1.0000	.9985	1.0933	1.0954	1.0933	1 1/2	1	-0.020	0.0449

delivery available from stock

prices price list online
www.igus.co.uk/en/clips2

order part number
example MYI-04-04

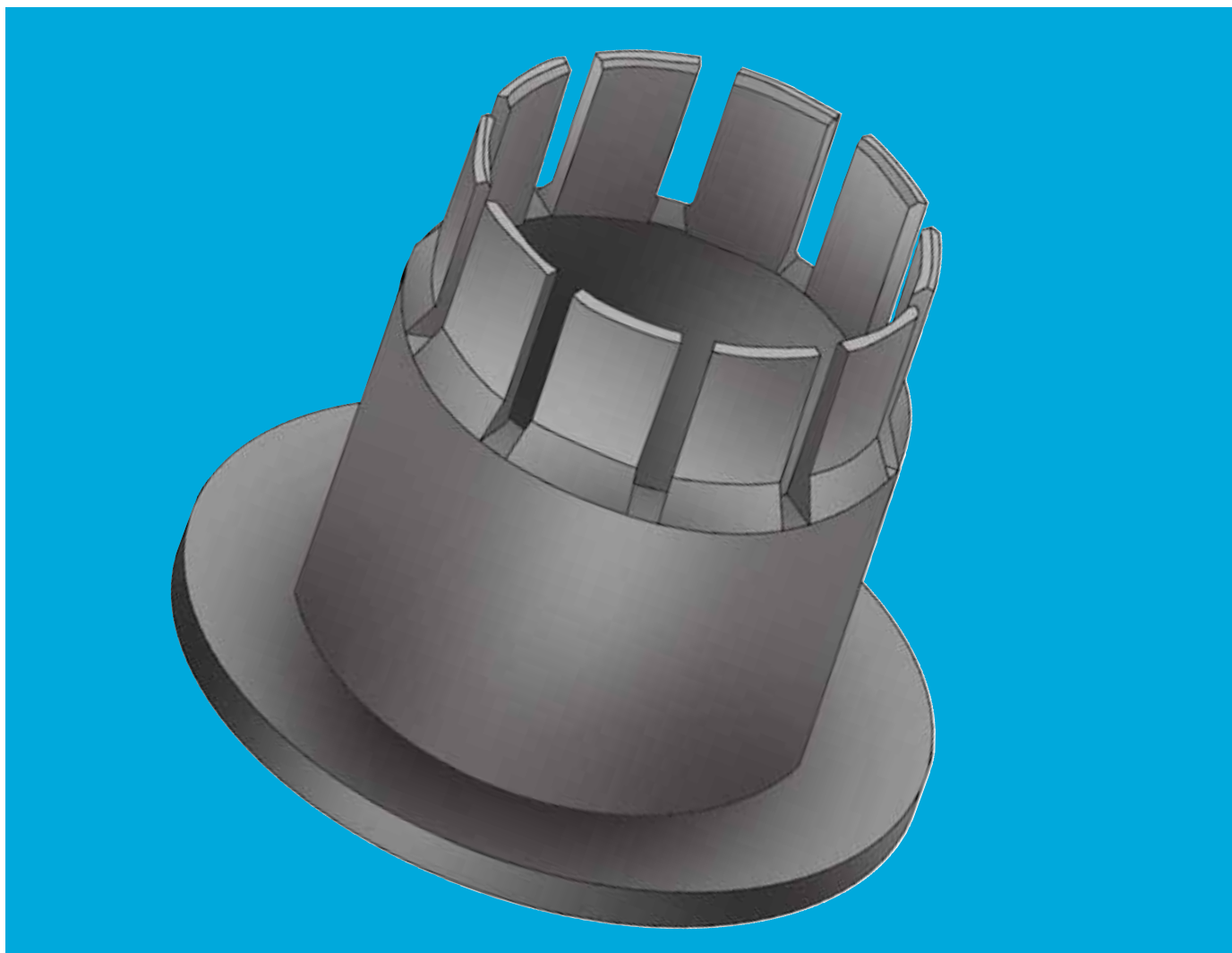

iglidur® MKM-Double Flange Bearing: press in – fold down – finished



Pressfit

Axial load on both sides

Compensation of tolerances of the sheet metal

Easy assembly

Axial pre-tension

Special design possible, conductive material available

iglidur® MKM Double Flange Bearing

Bearing with flanges on both ends made of iglidur® M250. Easy installation by pressing in and turning down the “second flange” in one step

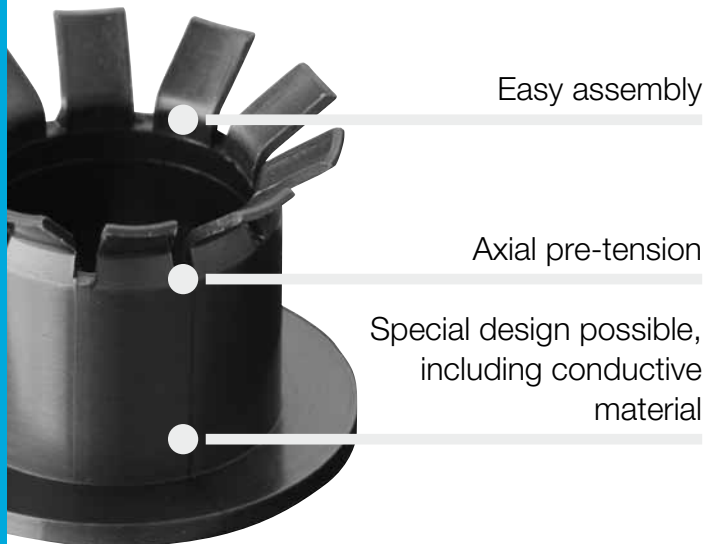
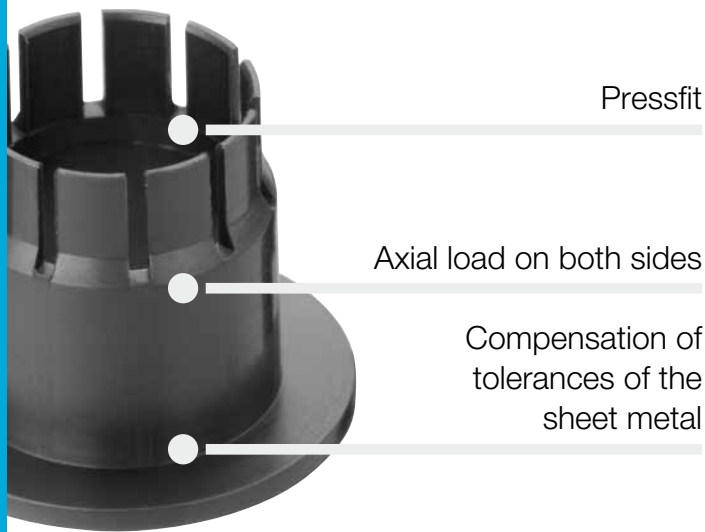

When to use it?

- When a double flanged bearing is needed
- When the housing bore is more than 4 mm long
- When the press fit force cannot be guaranteed
- When a double flange is required as a thrust surface



When not to use it?

- When extreme compressive strengths are required
 - ▶ **iglidur® G, page 61**
- When a simple press-fit bearing is required
 - ▶ **iglidur® M250, page 107**
- When a clip bearing for sheet metal is required
 - ▶ **iglidur® Clipslager, page 503**

Temperature

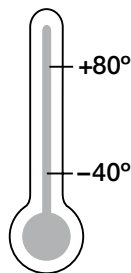

iglidur® MKM Double Flange Bearing | Product Range

Double Flange Bearing

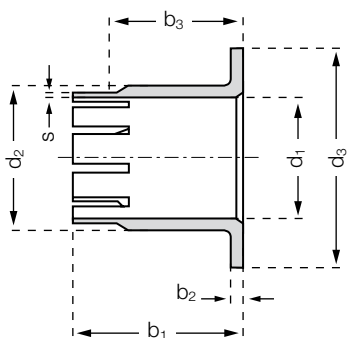

Order key

MKM-1012-10



Metal sheet thickness
Outer diameter d2
Inner diameter d1
Metric
Type (Form K)
Material iglidur® M250



Material:

iglidur® M250 ► page 107

Dimensions [mm]

Part number	d1	d2	d3	b1	b2	b3	s
MKM-1012-10	10	12	18	14	-0.14	±0.5	±0.1



Press in, fold down, finished: axial load on both sides



delivery available
time from stock



prices price list online
www.igus.co.uk/en/mkm



order part number
example MKM-1012-10

My Sketches

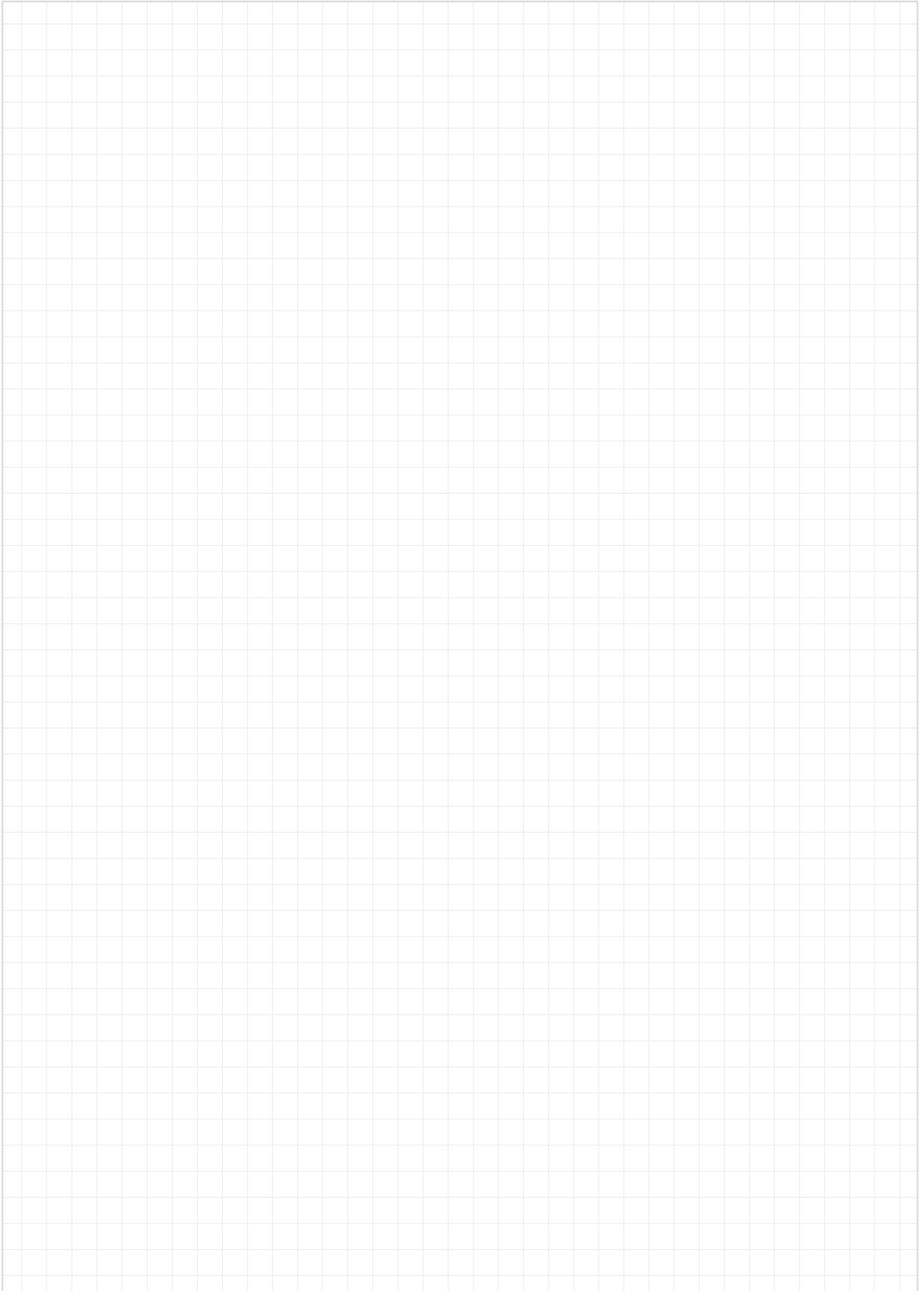

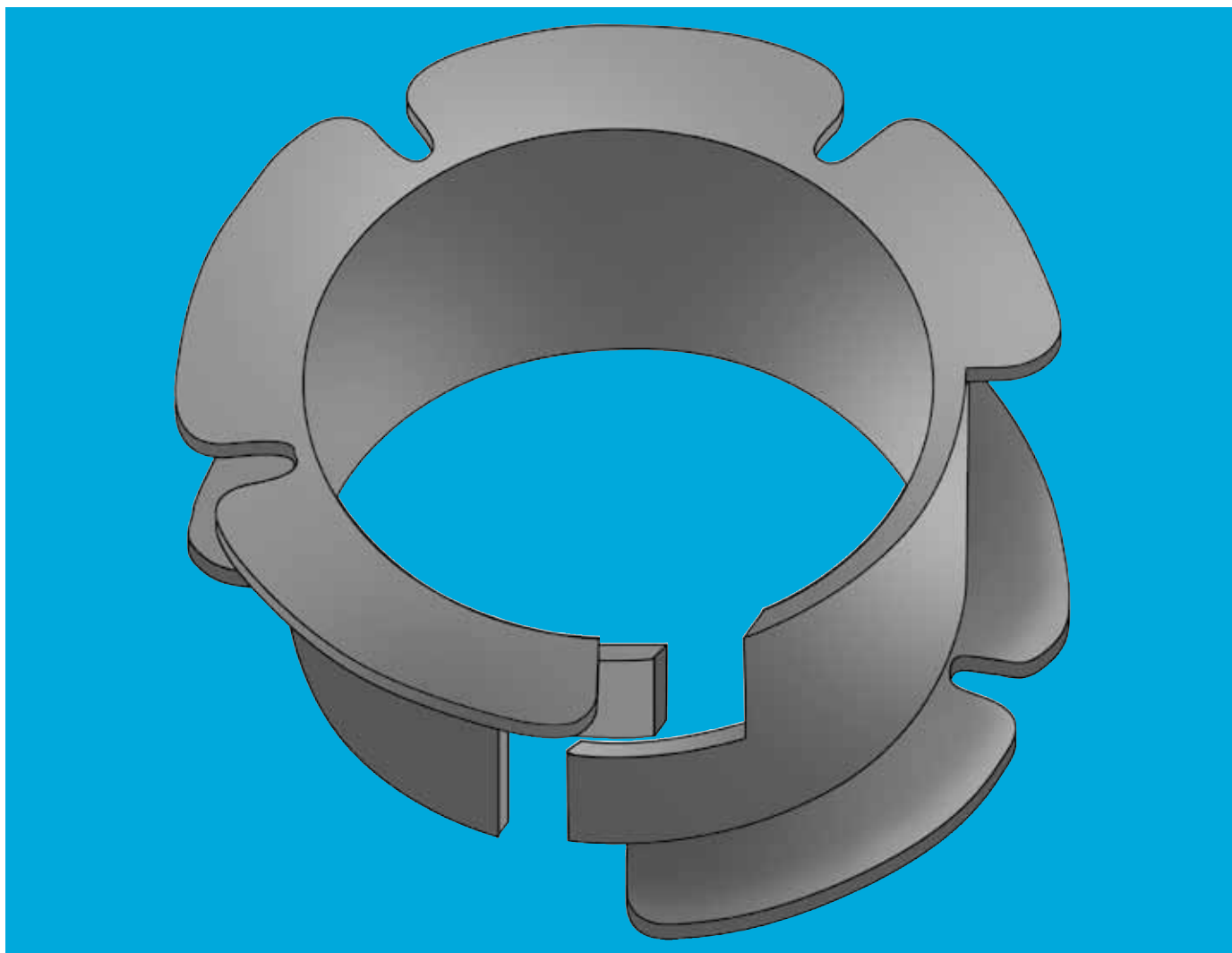

iglidur® MDM Double Flange Bearing – clip in, finished



Large flange surfaces

Symmetrical flange

Easy assembly

Clips in easily

Remains in place during E-Coat paint process

Special designs possible

iglidur® MDM Double Flange Bearing

Clip-in double flange bearing with symmetrical flange. The large second flange allows the bearing to take high axial forces, and the bearing is secure even when fitted to wide toleranced bores.

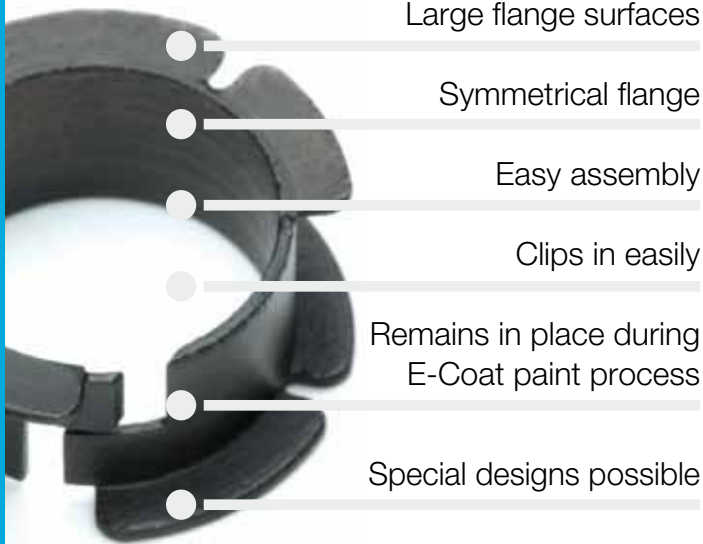

When to use it?

- When the axial security of an iglidur® clip bearing is not sufficient
- When there is a housing with very wide tolerance
- For high axial loads



When not to use it?

- When an automated assembly is required
 - ▶ **iglidur® MKM, page 513**
- When the iglidur® clip bearings offer adequate fit
 - ▶ **iglidur® clip bearings, page 503**
- When a large bearing length is required
 - ▶ **iglidur® MKM, page 513**

Temperature

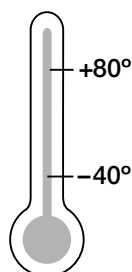

iglidur® Double Flange Bearing | Product Range

Double Flange Bearing

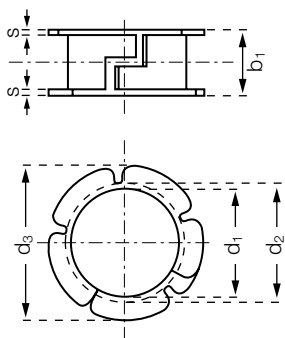

Order key

MDM-1213-06



- Sheet metal thickness
- Outer diameter d2
- Inner diameter d1
- Metric
- Type (Form D)
- Material iglidur® M250



Material:

iglidur® M250 ► page 107

Dimensions [mm]

Part number	d1	d2	d3	b1	s
MDM-1213-06	12	13	16.5	7	0.5

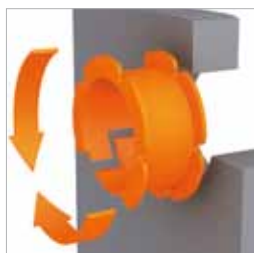

delivery available
time from stock



prices price list online
www.igus.co.uk/en/mdm



order part number
example MDM-1213-06

My Sketches

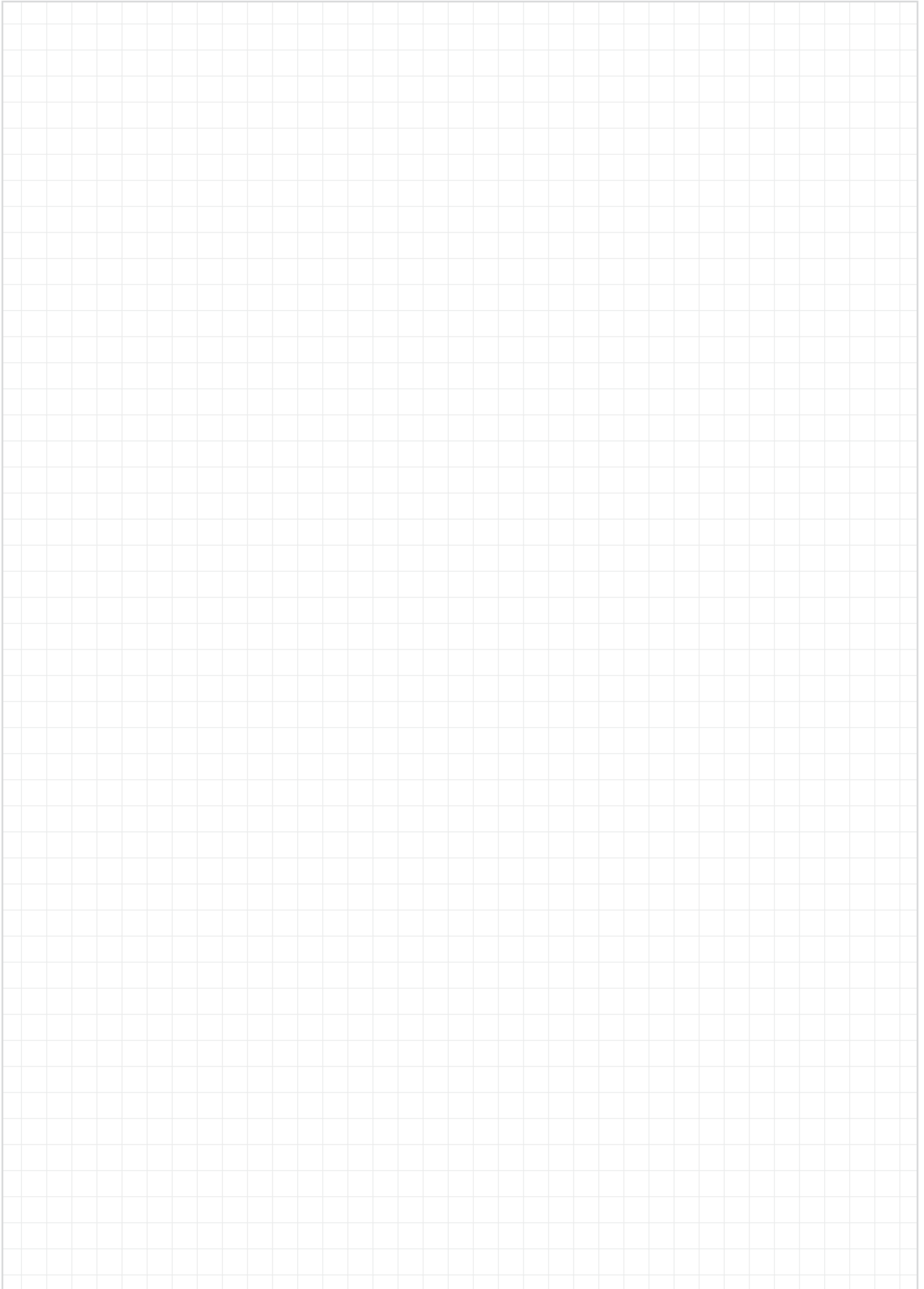

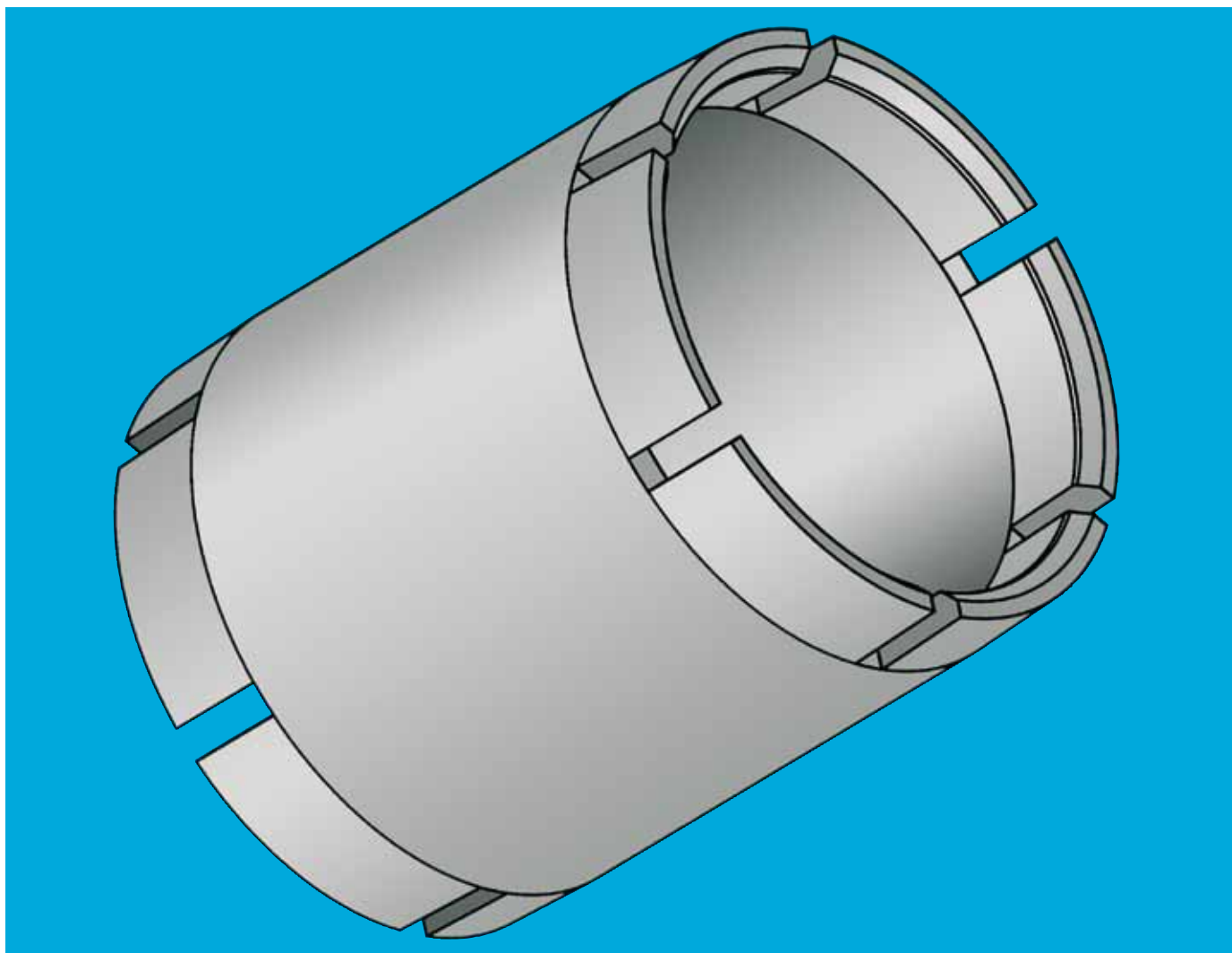

iglidur® JVSM/JVFM – Zero Clearance and Pre-Tensioned Bearings



Standard range from stock

Radial and axial pretension of bearings

Zero clearance in free state

Material: iglidur® J

Maintenance-free and predictable service life

iglidur® JVSM/JVFM

iglidur® JVSM and JVFM bearings are clearance-free in unloaded condition due to the axial and/or radial pretension. The iglidur® J material possesses extremely low coefficients of friction in dry operation and a very low stick-slip effect. Ideal for “anti-vibration mounting” of pedal box bearings, etc.

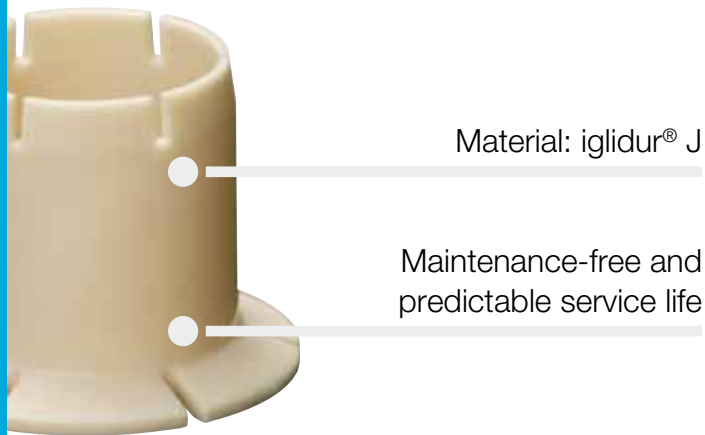
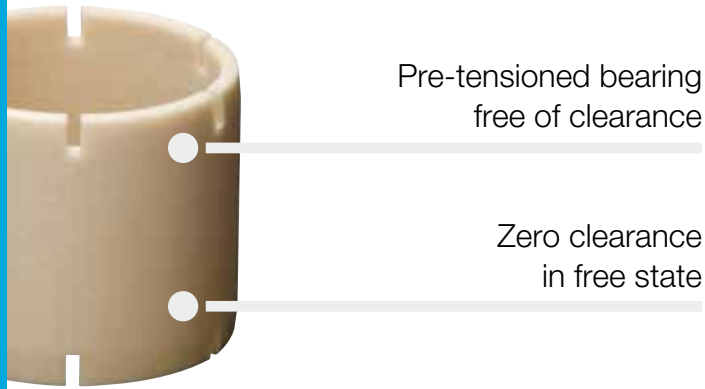

When to use it?

- When a radial and/or axial pretension of bearings is desired
- When a rattle-free bearing in the unloaded state is required
- When you want a zero clearance feel



When not to use it?

- When a bearing solution with reduced clearance is needed
▶ please contact us
- When the pretension has to withstand high radial forces
- When total zero clearance feature is required at high loads

Temperature

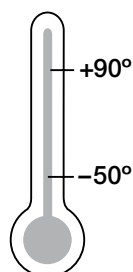

Product range

2 types
Ø 8–20 mm
more dimensions
on request



iglidur® JVSM/JVFM | Product Range

Sleeve Bearing

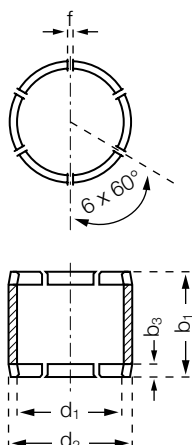

Order key

JVSM-0608-06

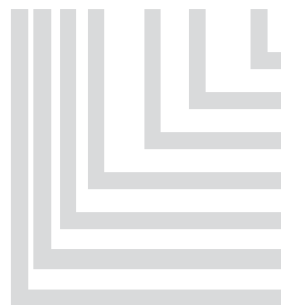

- Length b1
- Outer diameter d2
- Inner diameter d1
- Metric
- Type (Form S)
- pre-tensioned
- Material iglidur® J



Material:

iglidur® J ► page 89

Dimensions [mm]

Part number	d1	d1-Tolerance E10	d2	b1 h13	b3	f
JVSM-0608-06	6	+0.083 / +0.025	8	6	2.0	1
JVSM-0810-08	8	+0.083 / +0.025	10	8	2.0	1
JVSM-1012-10	10	+0.083 / +0.025	12	10	2.0	1
JVSM-1214-12	12	+0.102 / +0.032	14	12	2.0	1
JVSM-1416-14	14	+0.102 / +0.032	16	14	2.0	1
JVSM-1517-15	15	+0.102 / +0.032	17	15	2.5	1
JVSM-1820-18	18	+0.102 / +0.032	20	18	2.5	1
JVSM-2023-20	20	+0.124 / +0.040	23	20	2.5	1

d1 – Measured after pressfit in housing bore. d2 H7 within the measurement plane

Dimensions [Inch]

Part number	d1	d1-Tolerance		d2	b1 h13	b1-Tolerance
		max.	min.			
JVSI-0608-06	3/8	0.3773	0.3750	1/2	3/8	0.075
JVSI-0810-08	1/2	0.5040	0.5013	5/8	1/2	0.075
JVSI-1012-10	5/8	0.6297	0.6270	3/4	5/8	0.075
JVSI-1214-12	3/4	0.7541	0.7505	1 1/8	3/4	0.075
JVSI-1618-16	1	1.0041	1.0007	28.58	1	0.100

d1 – Measured after pressfit in housing bore. d2 H7 within the measurement plane



delivery available
time from stock



prices price list online
www.igus.co.uk/en/jvsm



order part number
example JVSM-0608-06

Flange Bearing

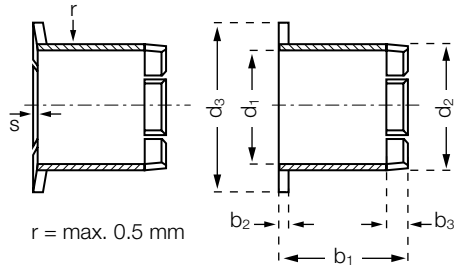

Order key

JVFM-0810-10



Length b1
Outer diameter d2
Inner diameter d1
Metric
Type (Form F)
pre-tensioned
Material iglidur® J



Material:

iglidur® J ► page 89

Dimensions [mm]

Part number	d1	d1-Tolerance E10	d2	d3	b1 h13	b2	b3	s ±0.1
JVFM-0810-10	8	+0.083 / +0.025	10	15	10	1	2.0	0.44
JVFM-1012-10	10	+0.083 / +0.025	12	18	10	1	2.0	0.53
JVFM-1214-12	12	+0.102 / +0.032	14	20	12	1	2.0	0.53
JVFM-1416-12	14	+0.102 / +0.032	16	22	12	1	2.0	0.53
JVFM-1517-15	15	+0.102 / +0.032	17	23	15	1	2.5	0.53
JVFM-1820-18	18	+0.102 / +0.032	20	26	18	1	2.5	0.53
JVFM-2023-20	20	+0.124 / +0.040	23	30	20	1.5	2.5	0.62



delivery available
time from stock



prices price list online
www.igus.co.uk/en/jvfm



order part number
example JVFM-0810-10

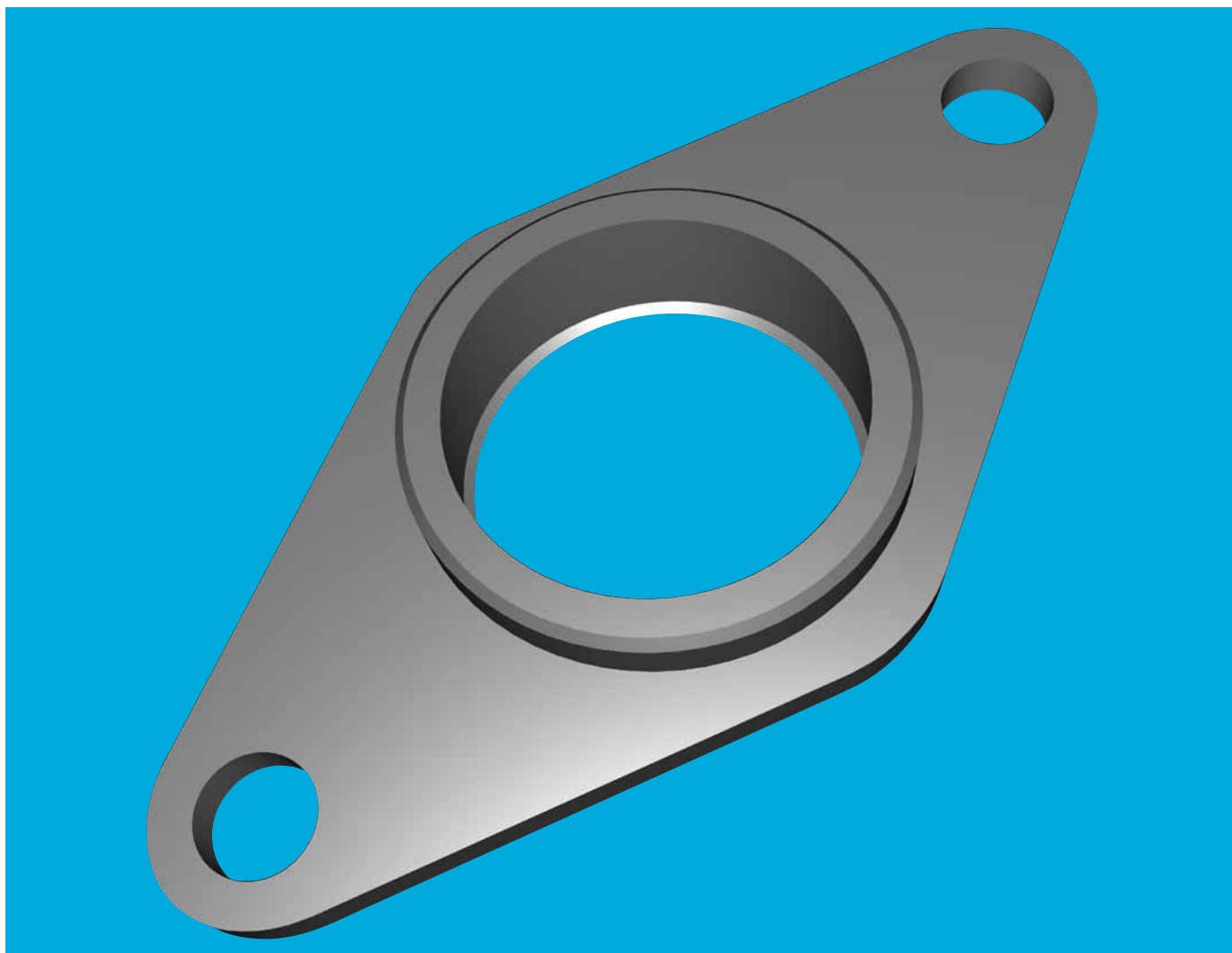

iglidur® – Flange Bearings



Standard range from stock

Very good wear resistance

Maintenance-free

Material: iglidur® G, iglidur® A180, iglidur® J and iglidur® X

Light weight

iglidur® Flange Bearings

With this design it is possible to use iglidur® high performance plain bearings in locations where recommended housing bore tolerances are not possible.



Very good
wear resistance

Maintenance-free

Material: iglidur® G,
iglidur® A180,
iglidur® J and iglidur® X

Light weight



When to use it?

- When a screw flanged bearing is sought
- When a clip bearing solution is not satisfactory as a sheet metal feedthrough
- When there is a housing with very rough tolerances
- When the tight fit of a press-fit bearing is not sufficient as an axial securing



When not to use it?

- When an additional angular compensation is required
 - ▶ **igubal® Flange bearings, page 631**
- When a screw connection is not possible
 - ▶ **iglidur® Clip bearings, page 503**
- When a large guide length is necessary
 - ▶ **iglidur® G, page 61**

Temperature

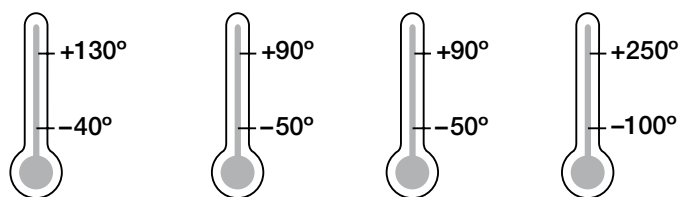

GFL

A180FL

JFL

XFL

Product range

1 style
Ø 10–35 mm
more dimensions
on request

iglidur® Flange Bearings | Technical Data

General Properties

With this design it is possible to use iglidur® high performance plain bearings in locations where recommended housing bore tolerances are not possible.

Due to the design of the bearing, high loads are possible although there is a minimal precision requirement of the housing. iglidur® maintenance-free flange bearings are made of iglidur® G, iglidur® J, iglidur® X or iglidur® A180. In this way, all the advantages of the iglidur® high performance polymers can be used, e.g. universal bearings, bearings with high wear-resistance or high temperature-resistance (up to +250 °C) or FDA-compliance.

Installation

Depending on the requirements, different mounting types can be considered. For low radial loads, it is sufficient to mount iglidur® flange bearings on one surface simply with two bolts. For higher radial loads, it is advisable to support the iglidur® flange bearing in a bore on the reinforced side facing the direction of the load. For this bore, large tolerances are permitted, since it serves only as additional support for the iglidur® flange bearing. In order to achieve higher radial loads in the bearings, the iglidur® flange bearing can be pressfit into a recommended housing bore. The additional bolts ensure the fit of the bearing in the housing.

For the installation of the iglidur® maintenance-free flange bearing, no special materials or tools are necessary.



Material data for available materials:

- iglidur® G ► page 61
- iglidur® A180 ► page 371
- iglidur® J ► page 89
- iglidur® X ► page 153



The installation of iglidur® flange bearing: simple and secure

Flange bearings

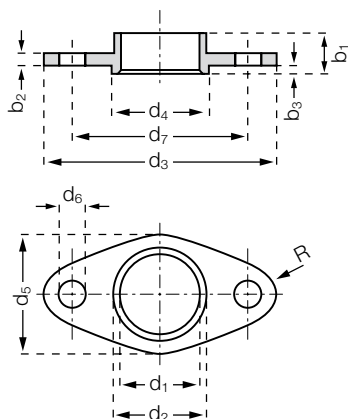

Order key

GFL-10



Dimensions [mm]

Part number	d1*	d2**	d3	d4	d5	d6	d7	b1	b2	b3	R (±0.2)
GFL-10	10	12	30	14	15	4.5	22	6	2	1	4
GFL-12	12	14	36	16	18	4.5	26	6	2	1	4.5
GFL-14	14	16	42	18	21	5.5	30	6	2	1	5
GFL-16	16	18	48	20	24	5.5	34	6	2	1	5.5
GFL-18	18	20	54	22	27	6.5	39	6	2	1	7
GFL-20	20	23	60	26	30	6.5	44	10	3	2	7
GFL-25	25	28	75	30	35	6.5	55	10	3	2	8.5
GFL-30	30	34	90	36	40	8.5	66	10	3	2	10
GFL-35	35	39	95	41	55	8.5	77	10	3	2	12
A180FL-10	10	12	30	14	15	4.5	22	6	2	1	4
A180FL-12	12	14	36	16	18	4.5	26	6	2	1	4.5
A180FL-16	16	18	48	20	24	5.5	34	6	2	1	5.5
A180FL-20	20	23	60	26	30	6.5	44	10	3	2	7
A180FL-25	25	28	75	30	35	6.5	55	10	3	2	8.5
A180FL-30	30	34	90	36	40	8.5	66	10	3	2	10
A180FL-35	35	39	95	41	55	8.5	77	10	3	2	12
JFL-10	10	12	30	14	15	4.5	22	6	2	1	4
JFL-12	12	14	36	16	18	4.5	26	6	2	1	4.5
JFL-14	14	16	42	18	21	5.5	30	6	2	1	5
JFL-16	16	18	48	20	24	5.5	34	6	2	1	5.5
JFL-20	20	23	60	26	30	6.5	44	10	3	2	7
JFL-25	25	28	75	30	35	6.5	55	10	3	2	8.5
JFL-30	30	34	90	36	40	8.5	66	10	3	2	10
JFL-35	35	39	95	41	55	8.5	77	10	3	2	12
XFL-10	10	12	30	14	15	4.5	22	6	2	1	4
XFL-12	12	14	36	16	18	4.5	26	6	2	1	4.5
XFL-14	14	16	42	18	21	5.5	30	6	2	1	5
XFL-16	16	18	48	20	24	5.5	34	6	2	1	5.5
XFL-20	20	23	60	26	30	6.5	44	10	3	2	7
XFL-25	25	28	75	30	35	6.5	55	10	3	2	8.5
XFL-30	30	34	90	36	40	8.5	66	10	3	2	10
XFL-35	35	39	95	41	55	8.5	77	10	3	2	12

delivery available
time from stock

prices price list online
www.igus.co.uk/iglidur-flange

order part number
example GFL-10

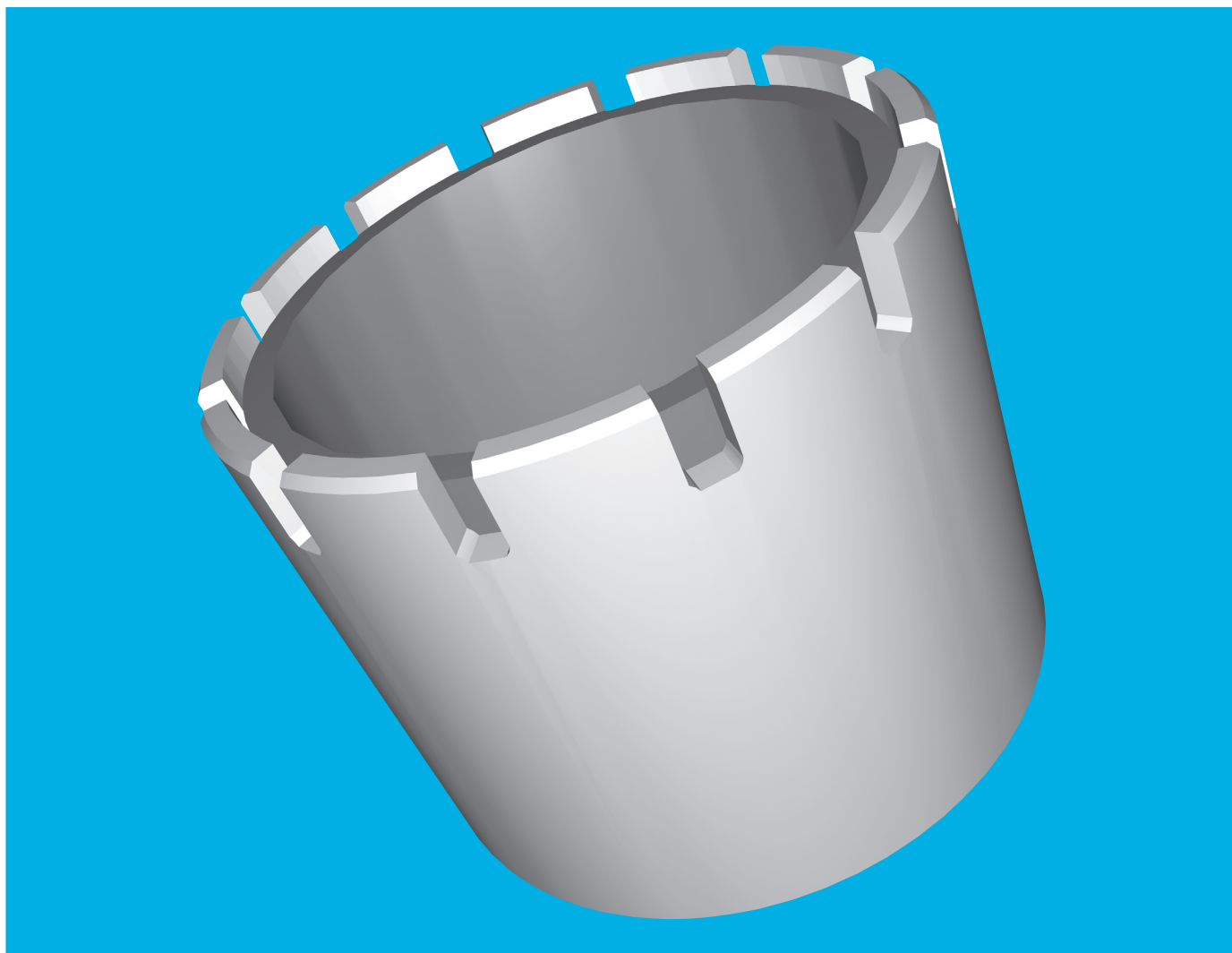

iglidur® PEP



Standard range from stock

Can be used with any shaft material

Very cost-effective

Easy to fit

Low coefficient of friction

iglidur® PEP

In standard plain bearing solutions, the shaft has a critical part to play, as important as the bearing itself. With the iglidur® PEP bearings, igus® takes a forging new trail highlighted by this enclosed and maintenance-free plain bearing design.

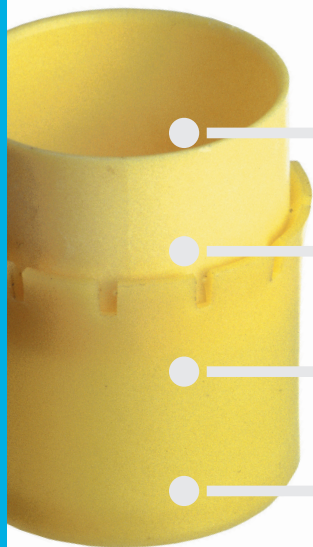

Can be used
with any shaft material

Very cost-effective

Easy to fit

Low coefficient of friction



When to use it?

- Cost-effective polymer bearing system
- Independent of the shaft material and of the shaft surface
- Protection of expensive and sensitive shafts



When not to use it?

- For high surface speeds
 - ▶ iglidur® J, page 89
- At high loads
 - ▶ iglidur® G, page 61
 - ▶ iglidur® Q, page 461
- For high temperatures
 - ▶ iglidur® V400, page 279
 - ▶ iglidur® X, page 153
 - ▶ iglidur® Z, page 299
- When low clearance bearings are required
 - ▶ iglidur® P, page 185
 - ▶ iglidur® X, page 153

Temperature

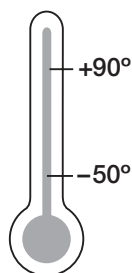

Product range

1 type
 Ø 6–20 mm
 more dimensions
 on request



iglidur® PEP | Technical Data

General Properties

Maintenance-free plain bearings are generally described as being able to slide on the shaft without any additional coating and/or lubrication. It is evident that shaft materials are as important as the bearing itself. iglus® is forging a new path with a plain bearing that is self-contained and maintenance-free. iglidur® PEP is an innovative design for lubricant-free polymer plain bearing systems with an inner and outer ring. The special feature; the sliding surface is the inner ring, and for the first, time shaft materials and shaft surfaces are not a concern. Even threads, rust and scratches do not affect the performance or reliability. With the control over the sliding surface and through considerable testing, the long term behaviour of the bearing system can be predicted precisely. Similar to ball bearings, the inner ring turns with the shaft in the polymer PEP plain bearing. Relative movements of the shaft with respect to the bearing are eliminated. This protects the shaft surface from wear and saves costs. An additional benefit; even the most sensitive or unusual materials can be used as the rotating shaft with this new polymer plain bearing. Due to the bearing materials used, the PEP polymer bearing is totally corrosion-free.

Wear Resistance

The wear resistance of PEP is of significant interest. For loads up to 1 N/mm² the test results are compelling. Here PEP polymer bearings obtain values that are comparable to most wear resistant metal-backed bearing systems. This is a very positive result, when you consider the reduced costs compared with the required shaft surface finish which is demanded by traditional bearings. The consistently low coefficient of friction is also an advantage to the user. Since the running surfaces are fixed, the tribological data can be calculated. The coefficients of friction of the PEP bearings are no longer based on the shaft materials or surface properties. If necessary, the coefficients of friction can be reduced further with a small amount of lubricant.

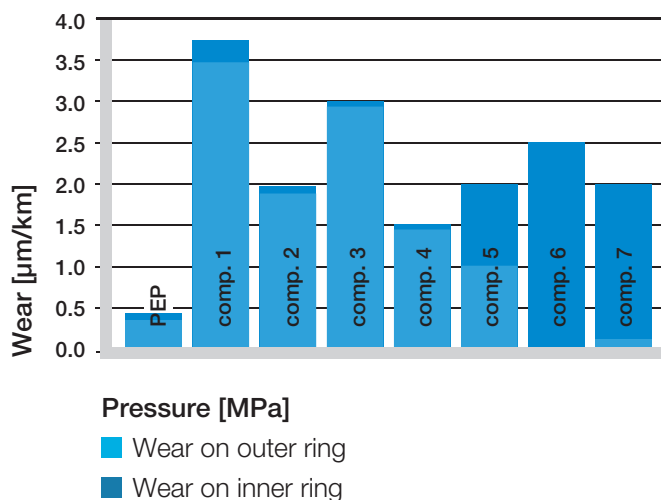

Graph 02: Wear experiments of different material combinations, p = 0.75 MPa, v = 0.3 m/s

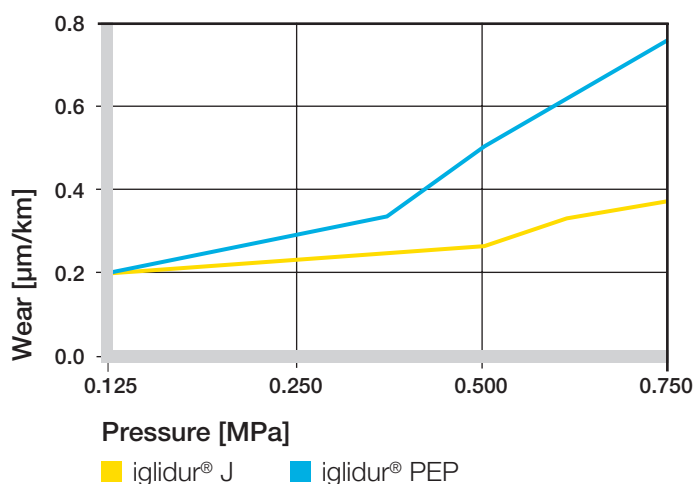

Graph 03: Wear of iglidur® PEP bearings as a function of the pressure, v = 0.3 m/s

Fitting

The installation of the PEP plain bearing could not be easier or faster. The bearings are manufactured to be press fitted into a recommended housing bore of H7 tolerance. Then, the shaft is inserted and fits tightly onto the inner ring. The inner bearing is clipped into the outer ring. This design makes it possible to pull the shaft out without removing the inner ring.

Sleeve Bearing

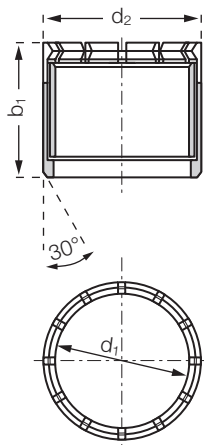

Order key

PEPSM-0610-10



Length b1
Outer diameter d2
Inner diameter d1
Metric
Type (Form S)
Material iglidur® J

Dimensions [mm]

Part number	d1	d2	b1
PEPSM-0610-10	6	10	10
PEPSM-0812-12	8	12	12
PEPSM-1014-12	10	14	12
PEPSM-1216-15	12	16	15
PEPSM-1620-20	16	20	20
PEPSM-2023-20	20	23	20

Dimensions [Inch]

Part number	d1	d2	b1
PEPSI-0406-06	1/4	3/8	3/8
PEPSI-0608-08	3/8	1/2	1/2
PEPSI-0810-08	1/2	5/8	1/2
PEPSI-1012-12	5/8	3/4	3/4
PEPSI-1214-12	3/4	7/8	3/4
PEPSI-1618-16	1	1 1/8	1



delivery available
time from stock



prices price list online
www.igus.co.uk/en/pep



order part number
example PEPSM-0610-10

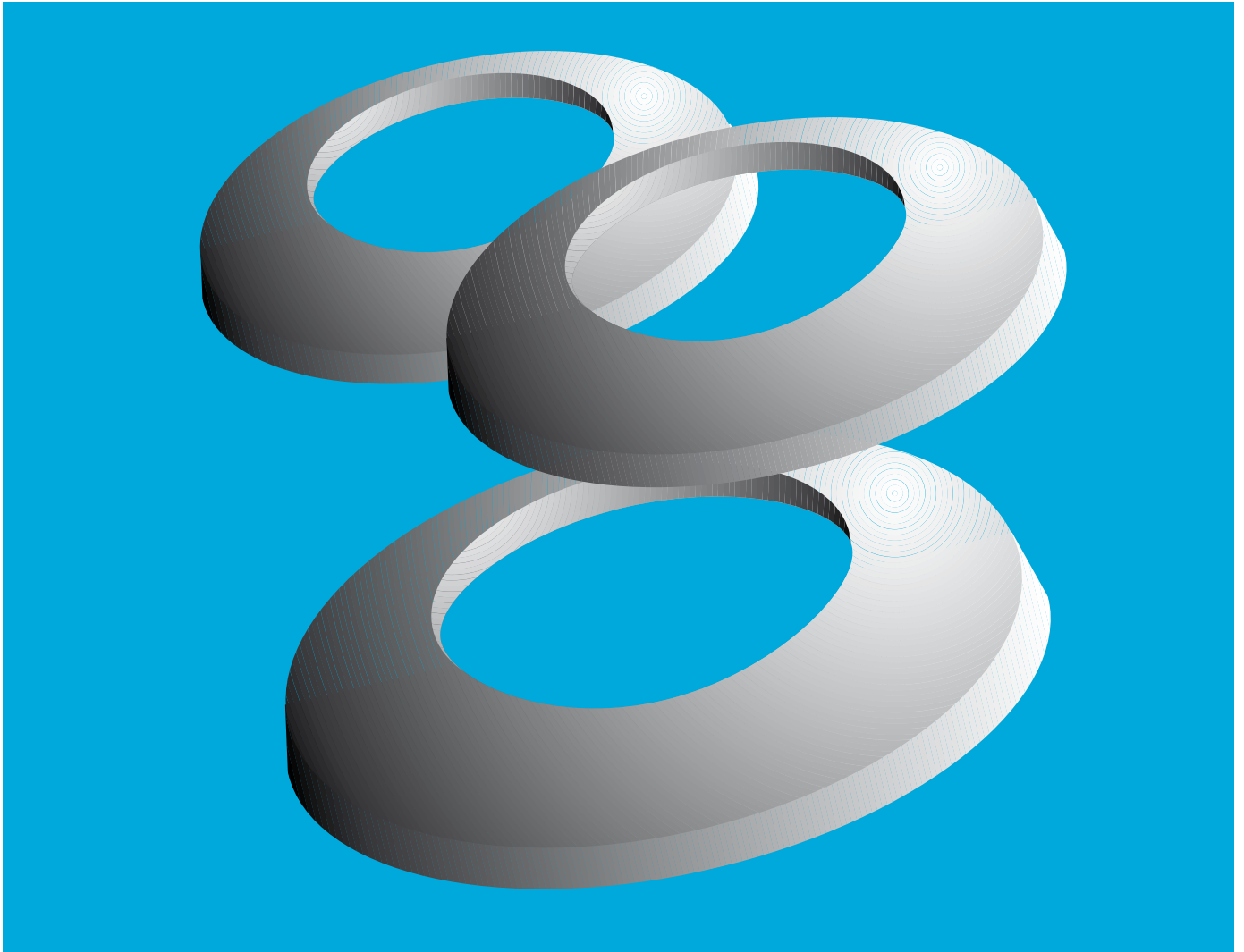

Polysorb – Polymer Disc Springs



Standard range from stock

Compensation for axial clearances and
manufacturing tolerances

Vibration dampening

Noise dampening

Corrosion-free

Light weight

Electrical and thermal insulation

iglidur® Polysorb

Spring washers are discs that can be axially loaded, which are concave in the axial direction. Polysorb disc springs require less space than other spring types, and are especially suitable for designs that do not require a high spring length.

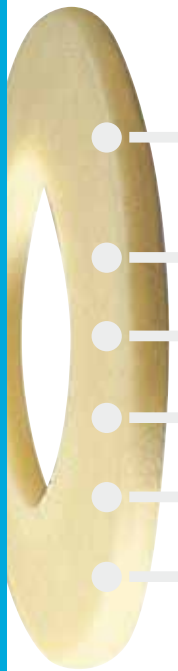

Compensation for axial clearances
and manufacturing tolerances

Vibration
dampening

Noise dampening

Corrosion-free

Light weight

Electrical and thermal insulation



When to use it?

- Application requires disc spring characteristics which are only possible in metal at a considerable expense (slotted design)
- Compensation of axial clearances and manufacturing tolerances
- Vibration dampening
- Noise reduction
- Non-magnetic
- Electrical and thermal insulation



When not to use it?

- When constant spring forces are necessary over wide temperature ranges
- When high spring forces are required

Temperature

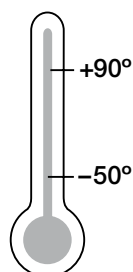

Product range

1 style
 Ø 10–40 mm
 more dimensions
 on request



General Properties

Spring washers are discs that can be axially loaded and which are concave in the axial direction. Polysorb disc springs require less space than other spring types, and are especially suitable for designs that do not require a high spring length as the height of a disc spring is relatively small. In practice, a number of disc springs are combined.

Disc springs that are alternately stacked increase the spring length proportionally to the amount of springs. The total spring force is as large as the force of one single disc spring. In order to increase the force, the disc springs can be parallel stacked to form a spring packet. Please contact us if you have any questions regarding the stacking of Polysorb disc springs.

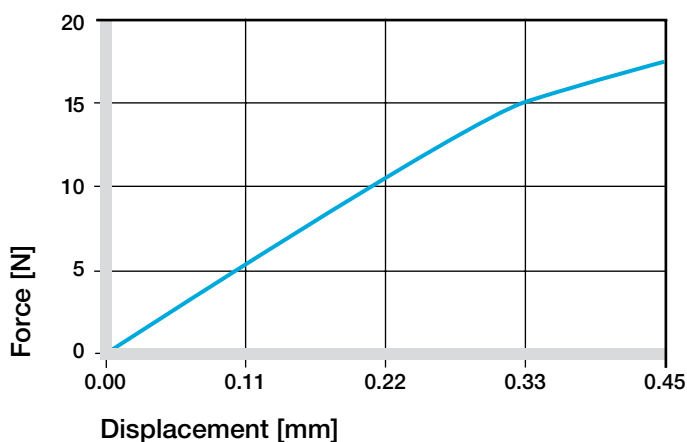

Graph 02: Experimental test results between the force ratio $F/F_{1,0}$ and the spring length ratio S/h_0 ($S_{1,0} = H_0$), using part number JTEM-10

Additional Properties

Chemical Resistance

Polysorb disc springs are resistant to diluted alkalines and very weak acids, as well as against fuels and all types of lubricants. The low moisture absorption permits the use in wet or moist environments.

Medium	Resistance
Alcohol	+
Hydrocarbons	+
Greases, oils without additives	+
Fuels	+
Diluted acids	0 to -
Strong acids	-
Diluted alkalines	+
Strong alkalines	+ to 0

+ resistant 0 conditionally resistant - not resistant
All data given at room temperature [+20 °C]

Table 05: Chemical resistance

Moisture Absorption

Polysorb disc springs absorb moisture and in the process the mechanical properties change. However, in the worst application case – a long term use in water – Polysorb disc springs still have a maximum spring force of 10 N.

Increased Temperatures

Increased temperatures reduce the rigidity of polymers. Polysorb disc springs still have a maximum spring force of 8 N at the maximum permissible temperature of +80 °C. The spring force against ambient temperature is shown in Graph 03.

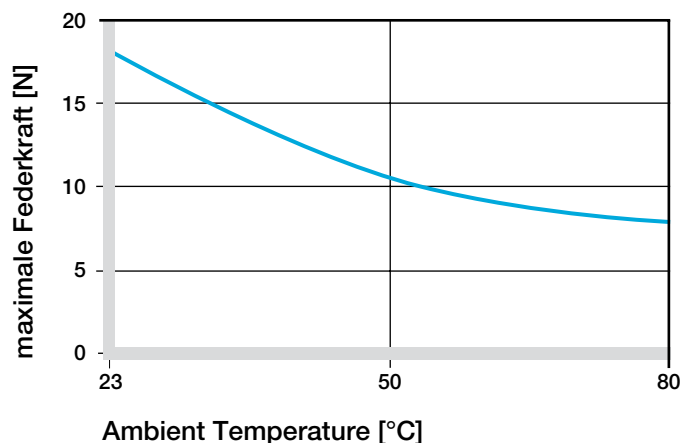

Graph 03: Effect of ambient temperature on the spring force, using part number JTEM-10

Polymer disc springs

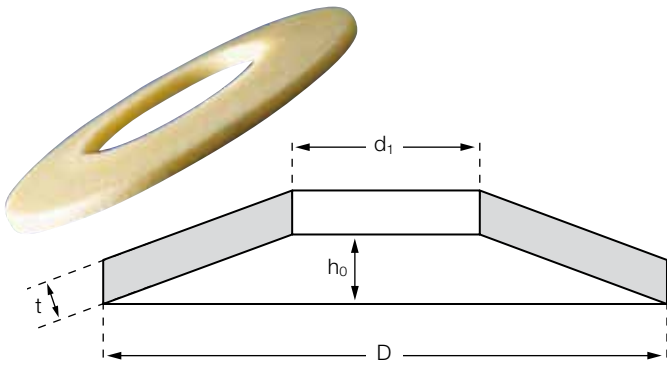

Order key

JTEM-05



Inner diameter d1

Metric

"Elastic spring"

Thrust washer style

Material iglidur® J

Dimensions based on DIN 2093

Dimension [mm]

Part number	Standard values: spring lengths and forces											
	D_e	D_i	t	h_0	$S_{0,25}$	$F_{0,25}$ [N]	$S_{0,5}$	$F_{0,5}$ [N]	$S_{0,75}$	$F_{0,75}$ [N]	$F_{1,0}$ [N]	M [g]
JTEM-05	10.0	5.2	0,5	0.25	0.06	1	0.13	2.4	0.19	3,6	5	0.04
JTEM-06	12.5	6.2	0,7	0.30	0.08	3	0.15	5.1	0.23	8	12	0.11
JTEM-08	16.0	8.2	0,9	0.35	0.09	4	0.18	8	0.28	11	12	0.20
JTEM-10	20.0	10.2	1.1	0.45	0.11	5	0.22	10	0.33	15	18	0.33
JTEM-12	25.0	12.2	1.5	0.55	0.14	9	0.28	18	0.42	27	35	0.85
JTEM-16	31.5	16.3	1.75	0.70	0.18	15	0.35	32	0.53	51	70	1.44
JTEM-20	40.0	20.4	2.25	0.90	0.23	35	0.45	70	0.68	110	140	3.10

The standard values for the spring lengths and forces are rounded mean values

Symbols and Units:

F	=	Force	$F_{0,25}$	=	Spring force 25 % displacement [N]
S	=	Spring length	$S_{0,5}$	=	50 % of max. spring displacement [mm]
D_e	=	Outside diameter [mm]	$F_{0,5}$	=	Spring force 50 % displacement [N]
D_i	=	Inside diameter [mm]	$S_{0,75}$	=	75 % of max. spring displacement [mm]
t	=	Plate thickness [mm]	$F_{0,75}$	=	Spring force 75 % displacement [N]
h_0	=	Maximum spring displacement [mm]	$F_{1,0}$	=	Spring force 100 % displacement [N]
$S_{0,25}$	=	25 % of maximal spring displacement [mm]	M	=	Mass of one disc spring [g]



delivery available
time from stock



prices price list online
www.igus.co.uk/en/polysorb



order part number
example JTEM-05

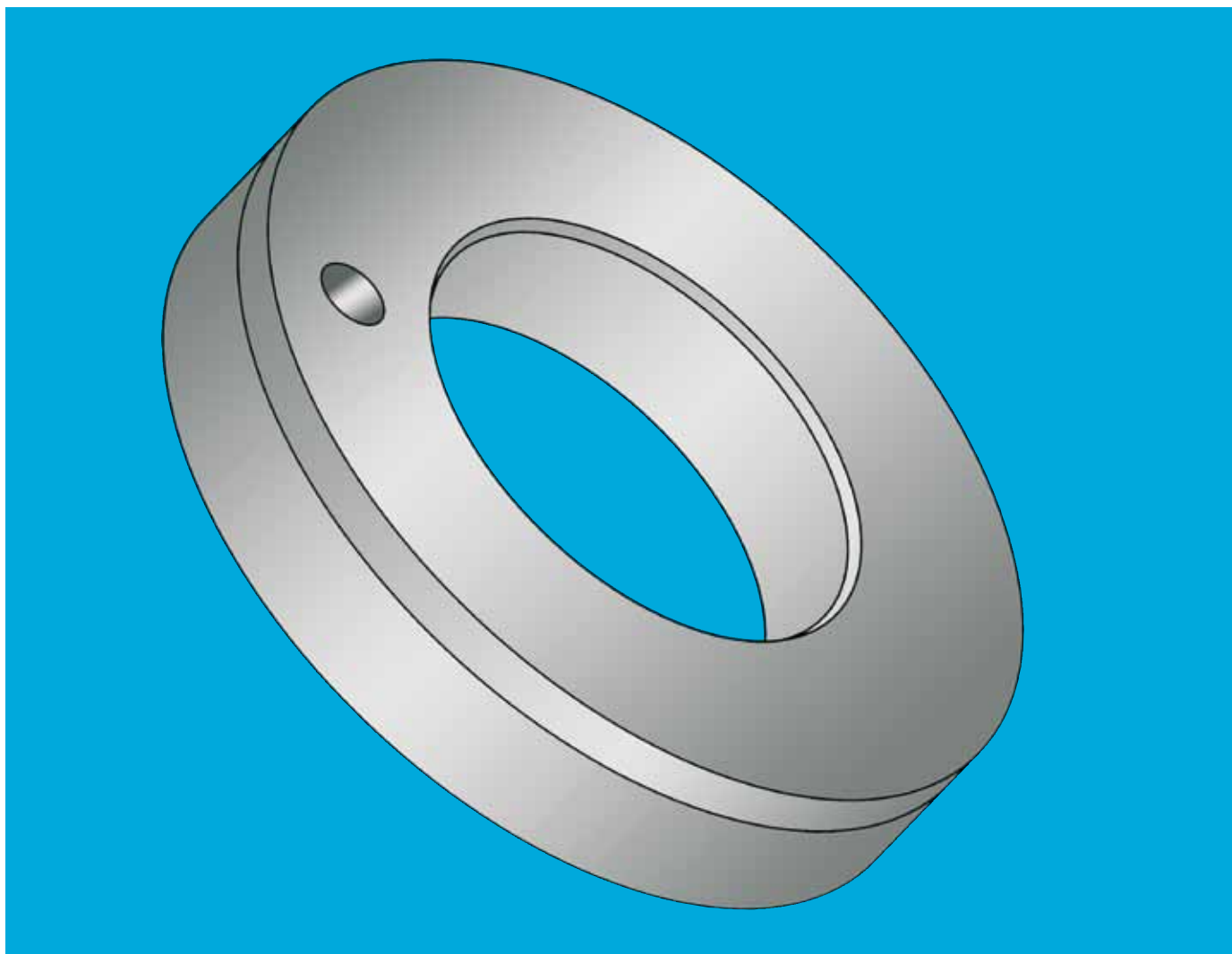

iglidur® JATM/VATM – matching sliding surfaces



Maintenance-free plain bearing system

For high performance

Matching sliding surfaces

Predictable service life

iglidur® JATM/VATM

iglidur® JATM/VATM consists of an anodized aluminum ring combined with an iglidur® bearing ring. This combination of materials results in low friction values and high wear resistance – without lubrication.

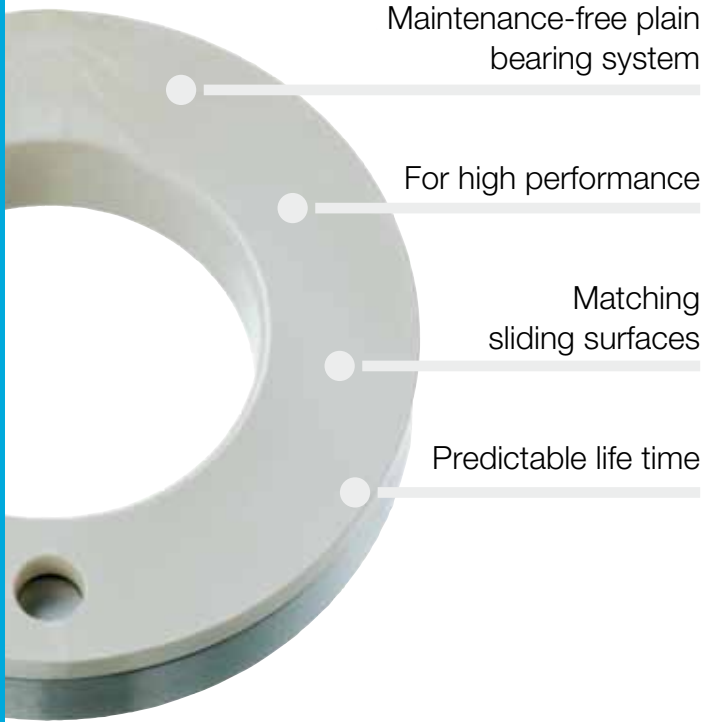

Maintenance-free plain bearing system

For high performance

Matching sliding surfaces

Predictable life time



When to use it?

- When an axial bearing system with defined tribological characteristics is required
- For extremely high wear resistance
- For a very low coefficient of friction is desired



When not to use it?

- When an additional angular compensation is required
 - ▶ **igubal® Axial bearing, page 663**
- When only a small installation space is available
 - ▶ **iglidur® J, Thrust Washer, page 102**
- For occasional use only
 - ▶ **iglidur® G, Thrust Washer, page 79**

Temperature

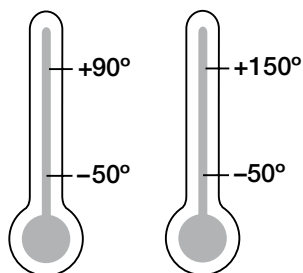

JATM

VATM

Product range

on request



We welcome your request for a thrust bearing customized for your application.

Please call us.

Phone +44 (0) 16 04-67 72 40



igidur® JATM/VATM | Technical Data

The calculated rates of wear rates of thrust bearing JATM

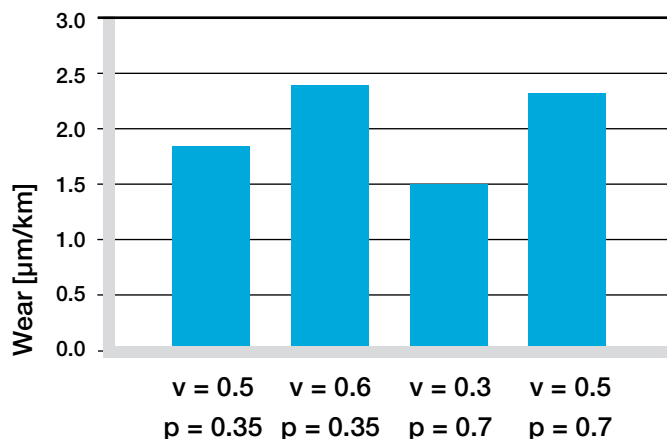

Graph 02: The graph shows the effect of pressure (p in MPa) and speed (v in m/s) on the thrust bearing wear

Calculated friction value of thrust bearing JATM

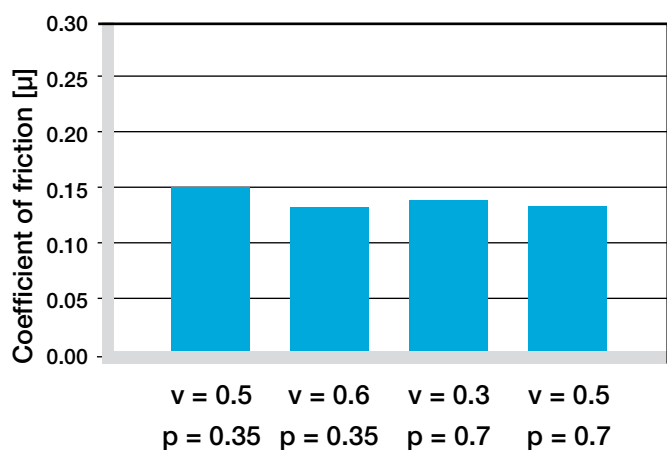

Graph 03: In a test, the friction values of the bearing systems were calculated at different speeds (v) and pressures (p) – (v in m/s, p in MPa)

Matching sliding surfaces

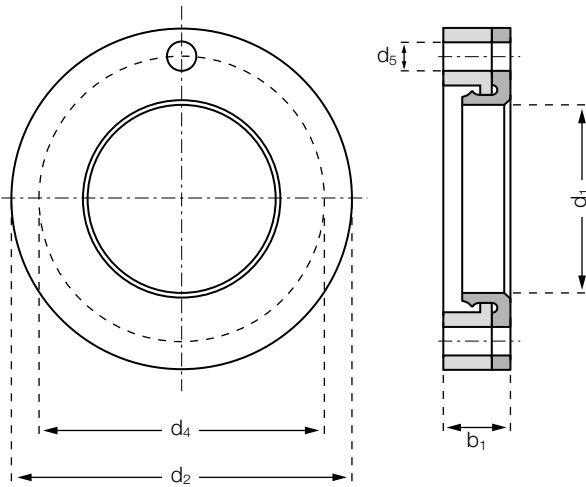

Order key

JATM-2036-070

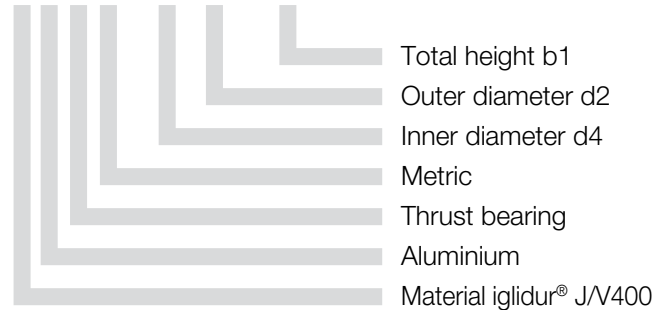

Material:

iglidur® J ► page 89

iglidur® V400 ► page 279

Dimensions [mm]

Part number	d1	d2	b1	d4	d5
JATM-2036-070	20	36	7	30	3
VATM-2036-070	20	36	7	30	3

 **delivery** available
time from stock

 **prices** price list online
www.igus.co.uk/en/jatm

 **order** part number
example JATM-2036-070

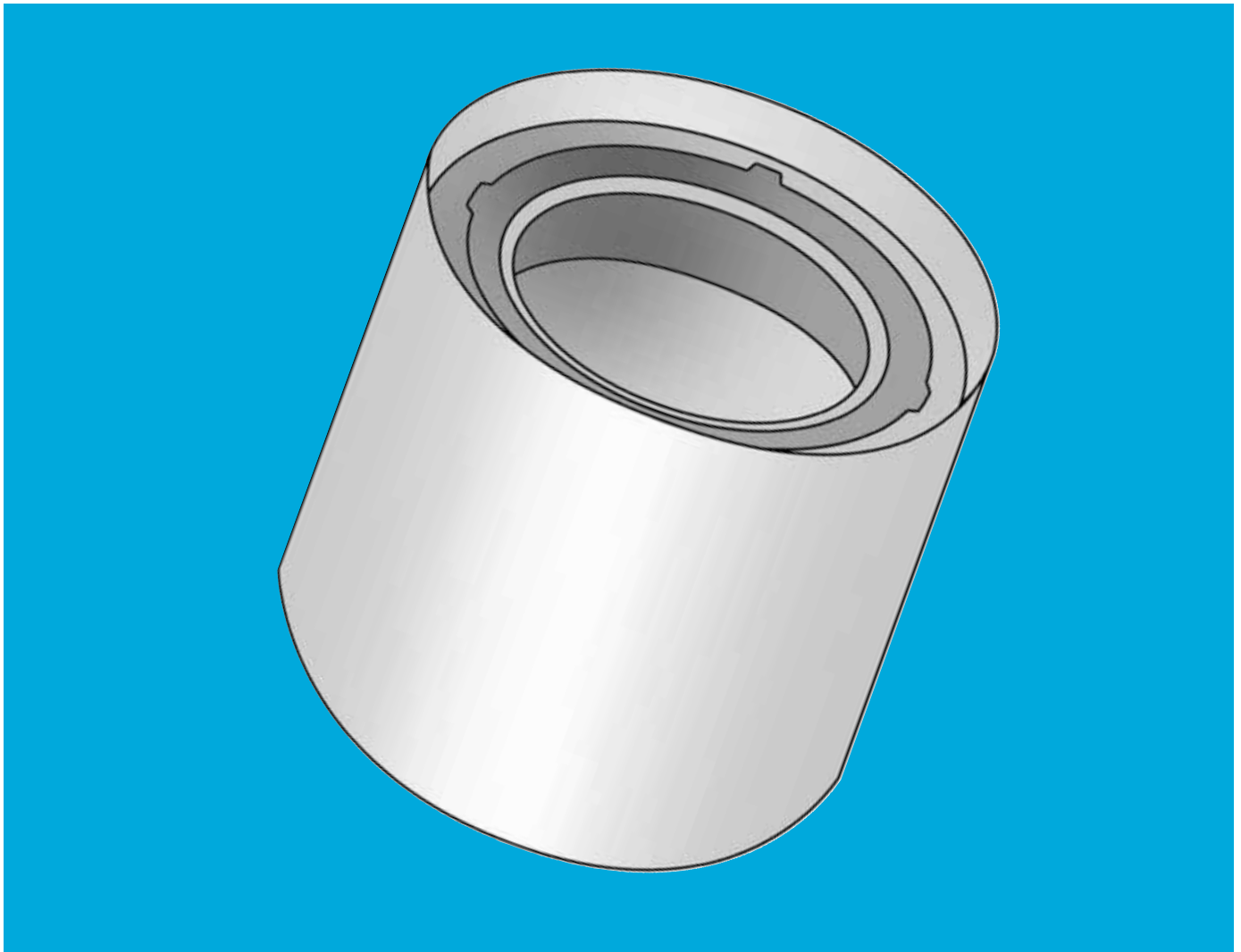

iglidur® Polymer Bearing with Lip Seal



Polymer bearing with incorporated radial shaft seal

Seals against the rotating shaft

Reduced space requirement and easy, fast installation

Can be manufactured with different types of seal

High-temperature version VDSM available

iglidur® Polymer Bearing with Lip Seal

Easy and quick to fit polymer plain bearing made from iglidur® J (JDSM) or iglidur® V400 (VDSM) with an integrated rotary lip seal, which protects against dust, dirt, and all unpressurized liquids.

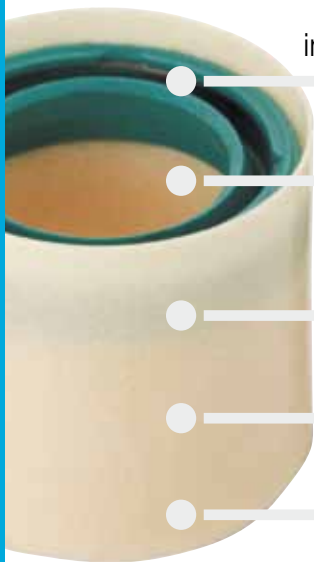

Polymer bearing with incorporated radial shaft seal

Seals against the rotating shaft

Reduced space requirement and easy, fast installation

Can be manufactured with different types of seal

High-temperature version VDSM available



When to use it?

- When the penetration of dirt and water spray should be prevented
- When only a small installation space is available in the axial direction
- When an existing seal should be integrated in a plain bearing



When not to use it?

- When pressurized media should be sealed
- When a permanent tensioned seal is required

Temperature

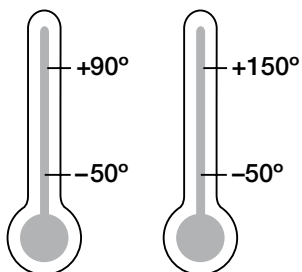

JDSM

VDSM

Product range

1 type
Ø 15 mm
other dimensions
on request



We welcome your request for a Polymer Bearing with integrated Seal customized for your application.

Please call us.

Phone +44 (0) 16 04-67 72 40



iglidur® Polymer Bearing with Lip Seal | Product Range

Polymer bearing with lip seal

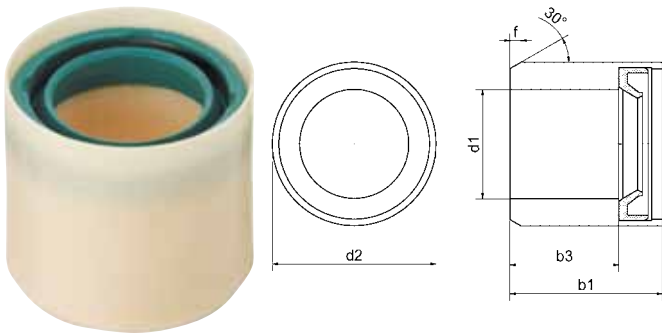

Order key

JDSM-1015-14

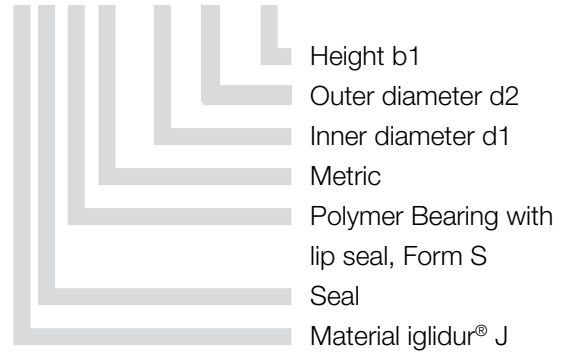

Material:

iglidur® J ► page 89

iglidur® V400 ► page 279

Dimensions [mm]

Part number	d1 E11	d2 Ø	b1 h13	b3	f
JDSM-1015-14	10	15	14	10	1
VDSM-1015-14	10	15	14	10	1



delivery available
time from stock



prices price list online
www.igus.co.uk/en/jdsm



order part number
example JDSM-1015-14

My Sketches

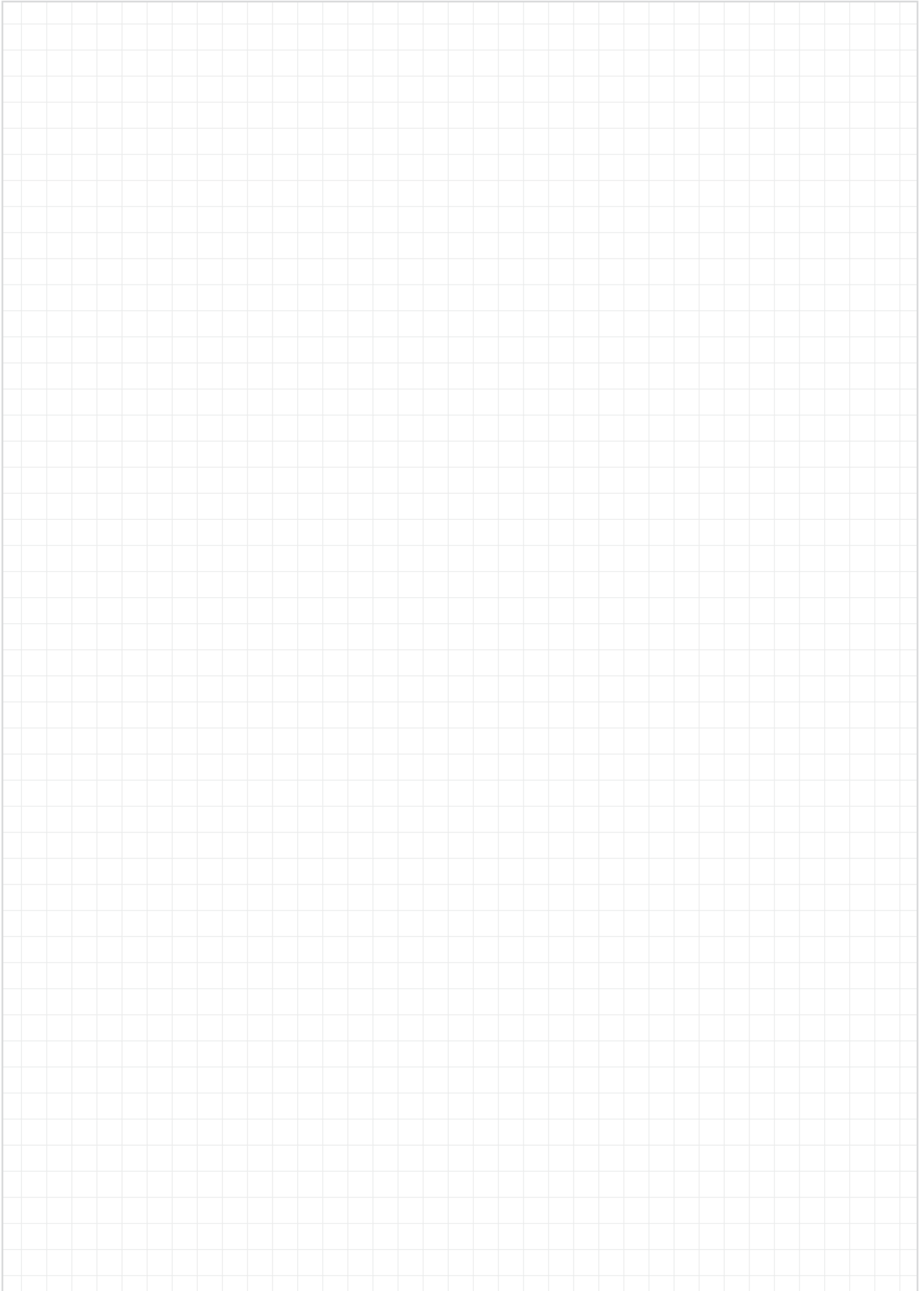

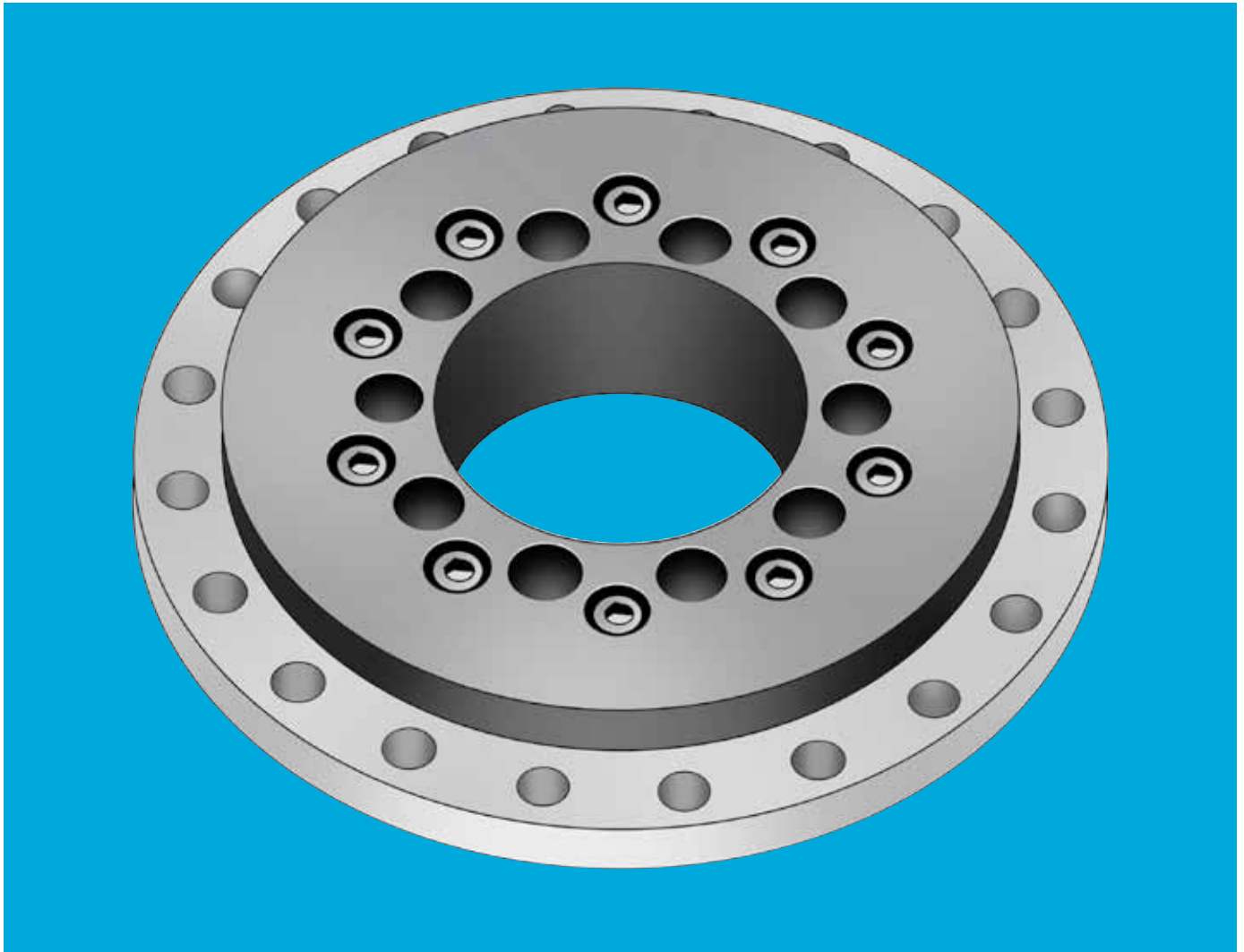

iglidur® PRT – Slewing Ring Bearing



Standard range from stock

Completely maintenance-free

Easy installation, interchangeable sliding pads

High wear resistance

For high load capacity, high stiffness

Available as stainless steel version

Wide range of accessories

iglidur® PRT

iglidur® PRT is a Slewing Ring Bearing with the proven advantages of the igus® polymer bearings. The sliding pads made from iglidur® high-performance polymers are completely free from maintenance and lubrication. All the housing components are made from anodized aluminum or stainless steel, the surfaces which mate with the iglidur® sliding pads are all hard anodized. All the fixing screws are stainless steel.



Completely maintenance-free

Easy installation,
interchangeable
sliding pads

High
wear resistance

For high load
capacity,
high stiffness

Stainless steel
versions available

Wide range of accessories

Temperature
dependant of type

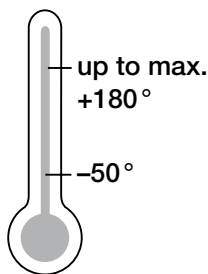

When to use it?

- When a ready-to-install fit solution is needed
- As a robust and corrosion resistant bearing unit for high loads
- For high tilting moments
- For use with different surrounding media
- When a lubrication and maintenance free Slewing Ring Bearing is needed
- For slow to medium speed



When not to use it?

- For fast rotations
- With temperatures over +180°C
- When there is not enough driving torque at high loads
- When highest precision is needed

Product range

3 types
42 dimensions
Ø 20–300 mm

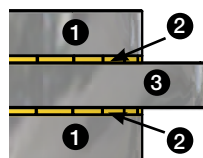

- ❶ **Type 01:**
Aluminum, hard anodized,
or Stainless steel V4A
- Type 02:**
iglidur® J4 or A180
- ❷ **Type 01:**
iglidur® J or H1
- ❸ **Type 01 and 02:**
Aluminum, anodized,
or Stainless steel V4A



iglidur® PRT | Application Examples



Typical sectors of industry and application areas

- Conveyors ● Automation
- Assembly stations ● Theatre/Stage and lighting technology ● Renewable energy etc.

Improve technology and reduce costs – 310 exciting examples for iglidur® plain bearings online

► www.igus.co.uk/iglidur-applications



Handling and conveyance system for semiconductor transport/box.



► www.igus.co.uk/movinghead



► www.igus.co.uk/welding-plant

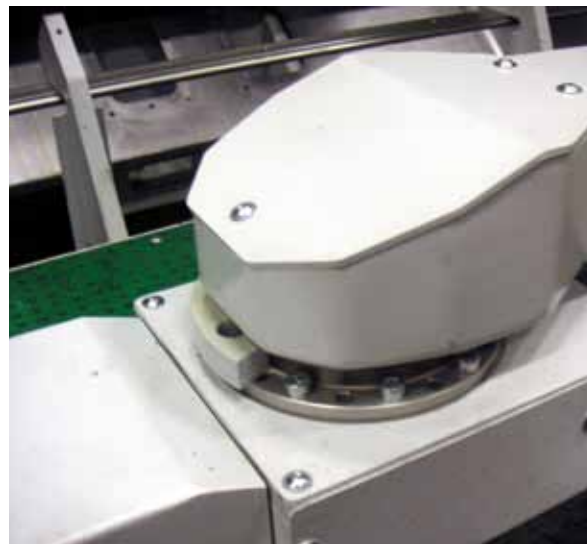

► www.igus.co.uk/cnc-machining

Slewing ring bearing

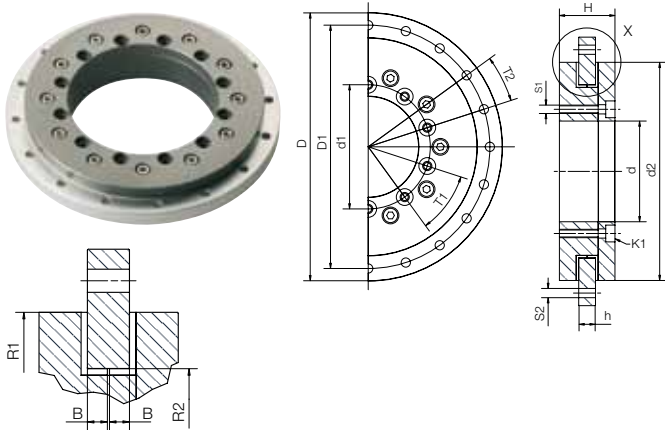

Order key

PRT-01-30-ES-H1



blank = iglidur® J
Sliding pads from iglidur® H1
Blank: Aluminium
ES: Stainless steel V4A
Inner-Ø
Type
Slewing Ring

Special properties

- Slewing ring with high stiffness
- Easy to fit
- High wear resistance
- Maintenance-free sliding pads made of iglidur® J ► [page 89](#)
- Available in aluminium or stainless steel V4A



Available in stainless steel

Dimensions [mm]

Part Number	D*	D1	d1	d	d2	H	h	T1	T2	S1	S2	K1	R1	R2	B
					±0,2							for screw			
PRT-01-30	100	91	42.5	30	82	29	10	8 x 45°	8 x 45°	M4	4.5	DIN 7984 M4	41	29	4.5
PRT-01-60	160	145	74	60	130	33	10	10 x 36°	20 x 18°	M5	5.5	DIN 912 M5	65	51.5	4.5
PRT-01-100	185	170	112	100	160	34	12	12 x 30°	16 x 22.5°	M5	5.5	DIN 912 M5	80	69	5.5
PRT-01-150	250	235	165	150	220	35	12	12 x 30°	16 x 22.5°	M5	5.5	DIN 912 M5	110	96.5	5.5
PRT-01-200	300	285	215	200	274	38	15	12 x 30°	16 x 22.5°	M6	7.0	DIN 912 M6	137	124	7.0
PRT-01-300	450	430	320	300	410	42	15	12 x 30°	16 x 22.5°	M8	9.0	DIN 7984 M8	205	186.6	7.0

* Tolerance according to DIN ISO 2768 mK

High temperature slewing ring bearing



Special properties

- Suitable up to +180°C, high chemical resistance
- For all 5 standard dimensions of style 01
- Body in aluminium or stainless steel,
- Sliding pads in iglidur® H1 ► [page 337](#)

Dimensions [mm]

Part Number	D*	D1	d1	d	d2	H	h	T1	T2	S1	S2	K1	R1	R2	B
					±0,2							for screw			
PRT-01-30-H1	100	91	42.5	30	82	29	10	8 x 45°	8 x 45°	M4	4.5	DIN 7984 M4	41	29	4.5
PRT-01-60-H1	160	145	74	60	130	33	10	10 x 36°	20 x 18°	M5	5.5	DIN 912 M5	65	51.5	4.5
PRT-01-100-H1	185	170	112	100	160	34	12	12 x 30°	16 x 22.5°	M5	5.5	DIN 912 M5	80	69	5.5
PRT-01-150-H1	250	235	165	150	220	35	12	12 x 30°	16 x 22.5°	M5	5.5	DIN 912 M5	110	96.5	5.5
PRT-01-200-H1	300	285	215	200	274	38	15	12 x 30°	16 x 22.5°	M6	7.0	DIN 912 M6	137	124	7.0
PRT-01-300-H1	450	430	320	300	410	42	15	12 x 30°	16 x 22.5°	M8	9.0	DIN 7984 M8	205	186.6	7.0

* Tolerance according to DIN ISO 2768 mK



delivery
time

available
from stock



prices

price list online

www.igus.co.uk/en/prt



order
example

part number

PRT-01-30

iglidur® PRT | Technical Data Type 01

Properties	Unit	PRT-01-30	PRT-01-60	PRT-01-100	PRT-01-150	PRT-01-200	PRT-01-300
Weight	kg	0.4	1.1	1.3	2.2	3.2	7.6
Max. axial load, static	N	27,000	50,000	55,000	80,000	100,000	150,000
Max. axial load, dynamic	N	7,000	15,000	16,000	25,000	30,000	90,000
Max. radial load, static	N	5,000	10,000	16,000	25,000	35,000	45,000
Max. radial load, dynamic	N	1,500	3,000	5,000	8,000	10,000	27,000
Max. rotat. speed dry running	1/min	250	200	150	100	80	50
Rigidity, axial	N/μm	100	300	400	450	500	500
Rigidity, radial	N/μm	50	65	65	65	65	65
Max. perm. tilting moment	Nm	200	800	1,500	2,000	3,800	5,000

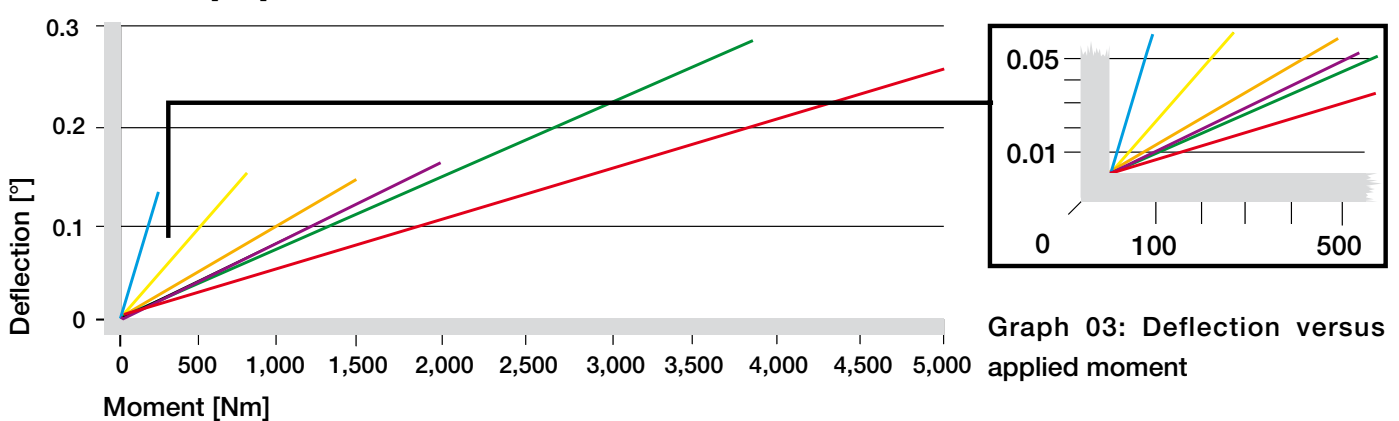
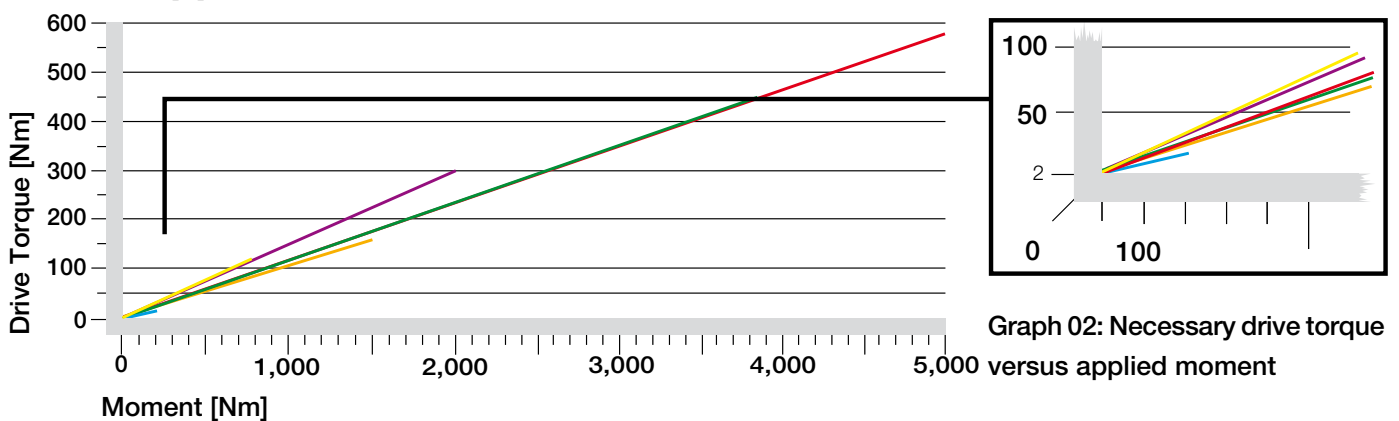
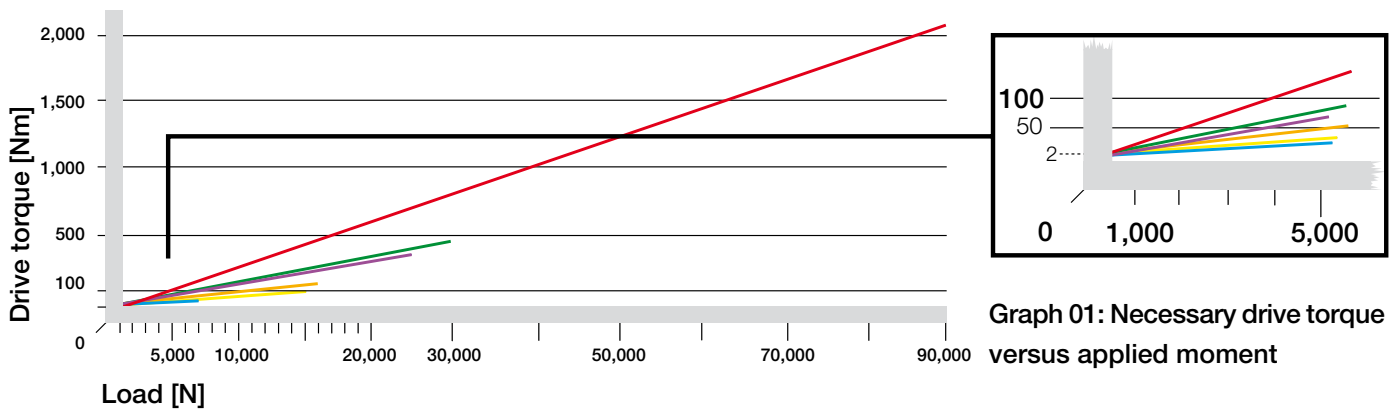

- PRT-01-30
M4, min.
8 screws
- PRT-01-60
M5, min.
10 screws
- PRT-01-100
M5, min.
12 screws
- PRT-01-150
M5, min.
12 screws
- PRT-01-200
M6, min.
12 screws
- PRT-01-300
M8, min.
12 screws

All load values assume the PRT is assembled with socket head screws (strength class 8.8) on the outside pitch circle diameter. For the assembly of the PRT the screws have to be inserted to a minimum thread depth of 2xd in every bore location in the outer ring. All data can be used for both lateral and horizontal assembly.

Slewing ring bearing with toothed outer ring

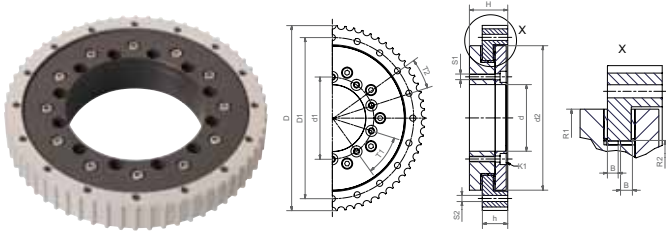

For each of the 6 sizes of the PRT-01 design version, 4 standards for toothed outer ring are available.

A classic spur gear teeth according to DIN3967 for use with a plastic gear or gear rack, and three commercially available belt profiles: T10, AT10, HTD8M. In the case of the externally toothed PRT, the inner ring is fixed and the outer ring driven.

At the same time the toothed outer ring with a special large diameter carries the gear.



Order key

PRT-01-30-TO-...



Dimensions [mm]

Part number	D1	d1	d	d2	h	T1	T2	S1	S2	K1	R1	R2	B	H
PRT-01-30-TO-...	91	42.5	30	82	21	8x45°	8x45°	M4	4,5	DIN 912 M4	41	29.0	4.5	(30.4)
PRT-01-60-TO-...	145	74.0	60	130	23	10x36°	20x18°	M5	5,5	DIN 912 M5	65	51.5	4.5	(34.5)
PRT-01-100-TO-...	170	112.0	100	160	25	12x30°	16x22,5°	M5	5,5	DIN 912 M5	80	69.0	5.5	(36.0)
PRT-01-150-TO-...	235	165.0	150	220	25	12x30°	16x22,5°	M5	5,5	DIN 912 M5	110	96.5	5.5	(37.5)
PRT-01-200-TO-...	285	215.0	200	274	30	12x30°	16x22,5°	M6	7,0	DIN 912 M6	137	124.0	7.0	(41.5)
PRT-01-300-TO-...	430	320.0	300	410	30	12x30°	16x22,5°	M8	9,0	DIN 912 M8	205	186.5	8.5	(46.5)

Spur gearing DIN3967

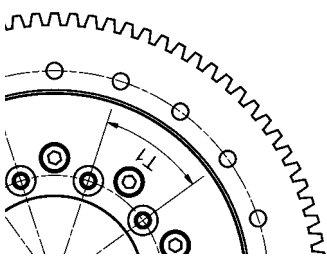

Part number	m	z	D
...-ST	2	54	(112)
...-ST	2	90	(184)
...-ST	2	96	(196)
...-ST	2	126	(256)
...-ST	2	152	(308)
...-ST	3	152	(462)

Toothed belt profile AT10

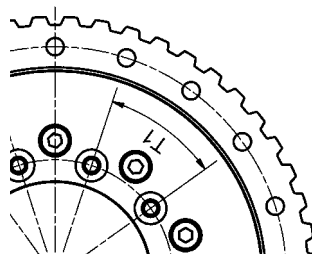

Part number	z	D
...-AT10	34	(106.4)
...-AT10	52	(163.8)
...-AT10	60	(189.2)
...-AT10	80	(252.9)
...-AT10	96	(303.9)

Toothed belt profile T10

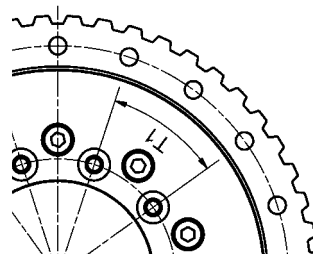

Part number	z	D
...-T10	34	(106.4)
...-T10	52	(163.8)
...-T10	60	(189.2)
...-T10	80	(252.9)
...-T10	96	(303.9)
...-T10	144	(456.7)

Toothed belt profile HTD8M

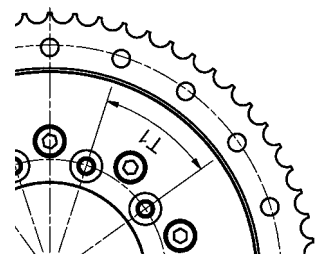

Part number	z	D
...-HTD8M	34	(105.6)
...-HTD8M	52	(166.7)
...-HTD8M	60	(189.2)
...-HTD8M	80	(253.3)
...-HTD8M	96	(304.3)
...-HTD8M	144	(457.1)



delivery available
time from stock



prices price list online
www.igus.co.uk/en/prt



order part number
example PRT-01-30-TO-...

iglidur® PRT | Product Range Type 02

Slewing ring bearing

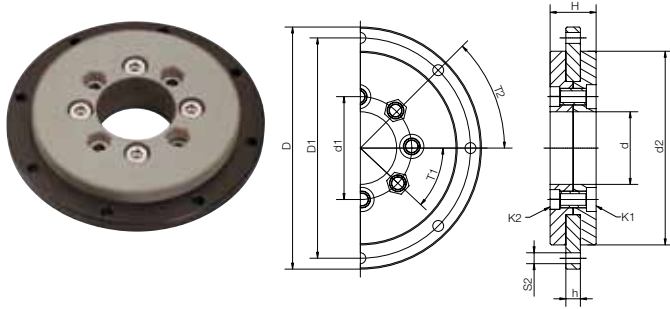

Order key

PRT-02-20-AL



AL: Aluminium
ES: Stainless steel V4A
Inner-Ø
Type
Slewing Ring

Special properties

- Slewing ring with very low weight
- Outer ring made from hard anodized Aluminium or stainless steel (V4A)
- iglidur® J4 – head rings – sliding against the outer ring without lubrication
- Low cost



Outer ring available in stainless steel as an option. Headrings made from iglidur® J4

Dimensions [mm]

Part number	D*	D1	d1	d	d2	H	h	T1	T2	S2	K1		K2	
											for screw		for screw	
PRT-02-20-AL/ES	80	70	31	20	60	16	5	6 x 60°	6 x 60°	4,5	DIN 6912-A2 M5	DIN 439-A2 M5		
PRT-02-30-AL/ES	100	91	42,5	30	80	19	6	8 x 45°	8 x 45°	4,5	DIN 7984 M5	DIN 439-A2 M5		
PRT-02-60-AL	160	145	86,0	60	130	30	10	12 x 30°	20 x 18°	5,5	DIN 931 M5X25	DIN 934 M5		

Slewing ring bearing, FDA compliant



Special properties

- For use in the food technology with headrings made from FDA-conform material iglidur® A180
- The stainless steel outer ring and the material iglidur® A180 ► **page 371** are suitable for the direct contact with food, pharmaceuticals and humidity.
- Low profile and low weight
- Ready to fit

Dimensions [mm]

Part Number	D*	D1	d1	d	d2	H	h	T1	T2	S2	K1		K2	
											for screw		for screw	
PRT-02-30-ES-A180	100	91	42,5	30	80	19	6	8 x 45	8 x 45	4,5	DIN 7984 M5	DIN 439-A2 M5		

Properties	Unit	PRT-02-20	PRT-02-30	PRT-02-60
Weight	kg	0,1	0,2	0,7
Max. axial load, stat.	N	13,000	25,000	45,000
Max. axial load, dyn.	N	4,000	7,000	12,000
Max. radial load, stat.	N	2,000	2,500	10,000
Max. radial load, dyn.	N	500	700	2,800
Max. rotat. speed dry running	1/min	250	200	120
Max. permissible tilting moment	Nm	60	100	200



delivery available
time from stock



prices price list online
www.igus.co.uk/en/prt



order part number
example PRT-02-20-AL/-ES

Slewing ring bearing in a new Low-Cost-Design

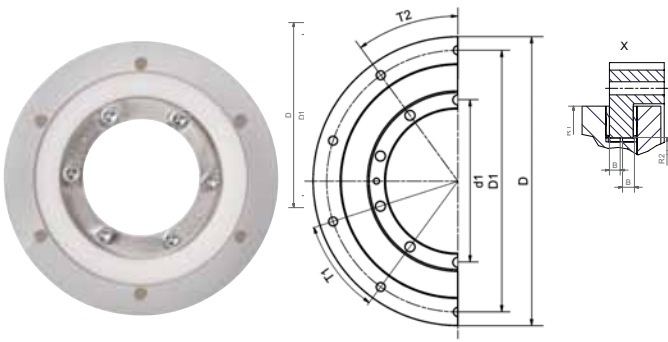

Order key

PRT-03-80

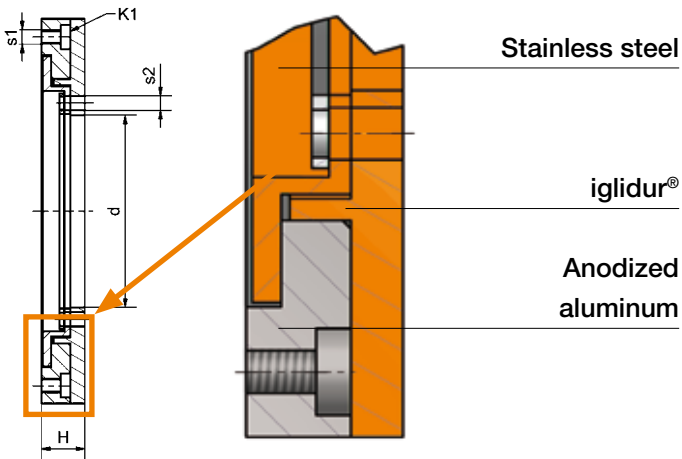
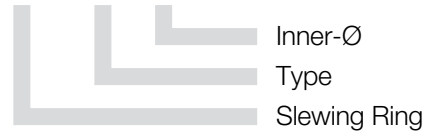

iglidur® PRT slewing ring bearings in a new economic design. Ongoing cost engineering has resulted in a new design, with a greater use of plastics.

- Maintenance- and lubrication-free
- Low priced and lightweight
- Low installation space
- Ready to fit

Properties	Unit	PRT-03-80
max. rpm	rpm	120
max. recommended static load rating axial (push direction)	N	12,000
recommended dynamic load rating axial (push direction)	N	45,000
max. recommended static load rating axial (pull direction)	N	5,000
max. recommended dynamic load rating axial (pull direction)	N	2,000
max. recommended static overturning moment	Nm	120
max. recommended static load rating radial	N	4,000
max. recommended dynamic load rating radial	N	1,000
max. temperature	°C	60

Dimensions [mm]

Part number	D	D1	d1	d	H	T1	T2	s1	s2	K1
PRT-03-80	160	145	90	80	18	10 x 36°	10 x 36°	M6	6	M5



delivery available
time from stock



prices price list online
www.igus.co.uk/en/prt



order part number
example PRT-03-80

iglidur® PRT | Product Range Accessories

Hand clamp

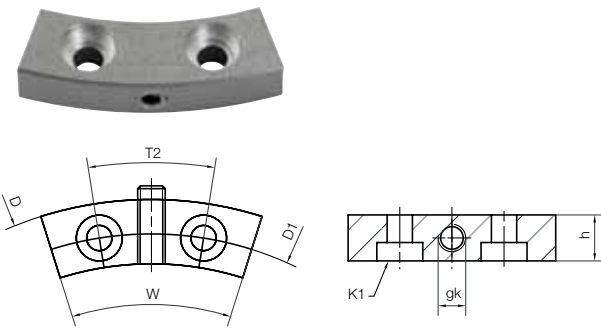

Graph 04: PRT with fitted manual clamp

- With 1 Nm screw torque, a holding torque up to 10 Nm is possible
- Easy to screw onto outer ring

Dimensions [mm]

Part number	D	D1	T2	K1	h	gk	W
PRT-HK-60	160	145	20 x 18°	DIN 7984 M5	10	M6	35°
PRT-HK-100*	205	185	16 x 22.5°	DIN 7984 M5	12	M6	40°
PRT-HK-200*	320	300	16 x 22.5°	DIN 7984 M6	15	M6	40°

* Only available with large outer rings

Slewing ring bearing with large outer ring

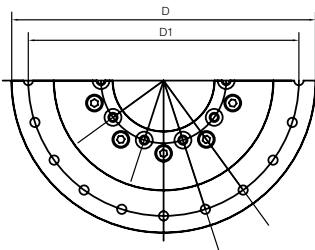



Dimensions [mm]

Part number	D	D1
PRT-01-100-M-ARG*	205	185
PRT-01-100-M-ARGG*	205	185
PRT-01-100-M-ARGS*	205	185
PRT-01-200-M-ARG*	320	300
PRT-01-200-M-ARGG*	320	300
PRT-01-200-M-ARGS*	320	300

* Ending: -G standard, -GG thread- or -GS counterbore

Other dimensions such as Standard type PRT-01 ► page 548

 delivery time	available from stock	 prices	price list online www.igus.co.uk/en/prt	 order example	part number PRT-HK-60 PRT-01-100-M-ARG
--	----------------------	---	---	--	--

Drive pin

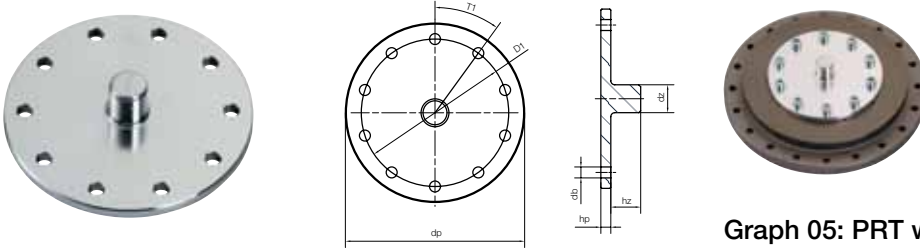

Graph 05: PRT with assembled drive pin

Dimensions [mm]

Part number	dp	hp	dz	hz	D1	T1	db
PRT-AZ-30	55	5	10	15	42.5	8 x 45°	4.5
PRT-AZ-60	90	5	14	15	74	10 x 36°	5.5

Spacing rings made from anodized aluminum

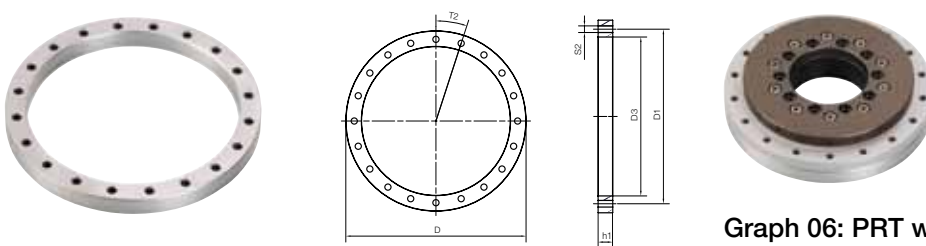

Graph 06: PRT with assembled spacing ring

Dimensions [mm]

Part number	D	D1	T2	S2	D3	h1
PRT-01-30-DR	100	91	8 x 45°	4.5	84	11
PRT-01-60-DR	160	145	20 x 18°	5.5	132	13
PRT-01-100-DR	185	170	16 x 22,5°	5.5	162	13
PRT-01-150-DR	250	235	16 x 22.5°	5.5	222	13
PRT-01-200-DR	300	285	16 x 22.5°	7.0	276	13

Spacing rings made from polymer

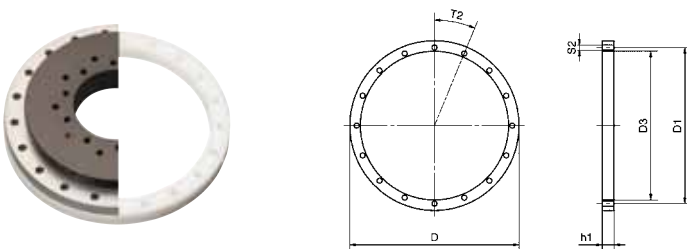

Dimensions [mm]

Part number	D	D1	T2	S2	D3	h1
PRT-01-30-DR-POM	100	91	8 x 45°	4.5	84	11
PRT-01-60-DR-POM	160	145	20 x 18°	5.5	132	13
PRT-01-100-DR-POM	185	170	16 x 22.5°	5.5	162	13



delivery
time

available
from stock



prices

price list online

www.igus.co.uk/en/prt



order
example

part number

PRT-AZ-30

PRT-01-03-DR

PRT-01-03-DR-POM

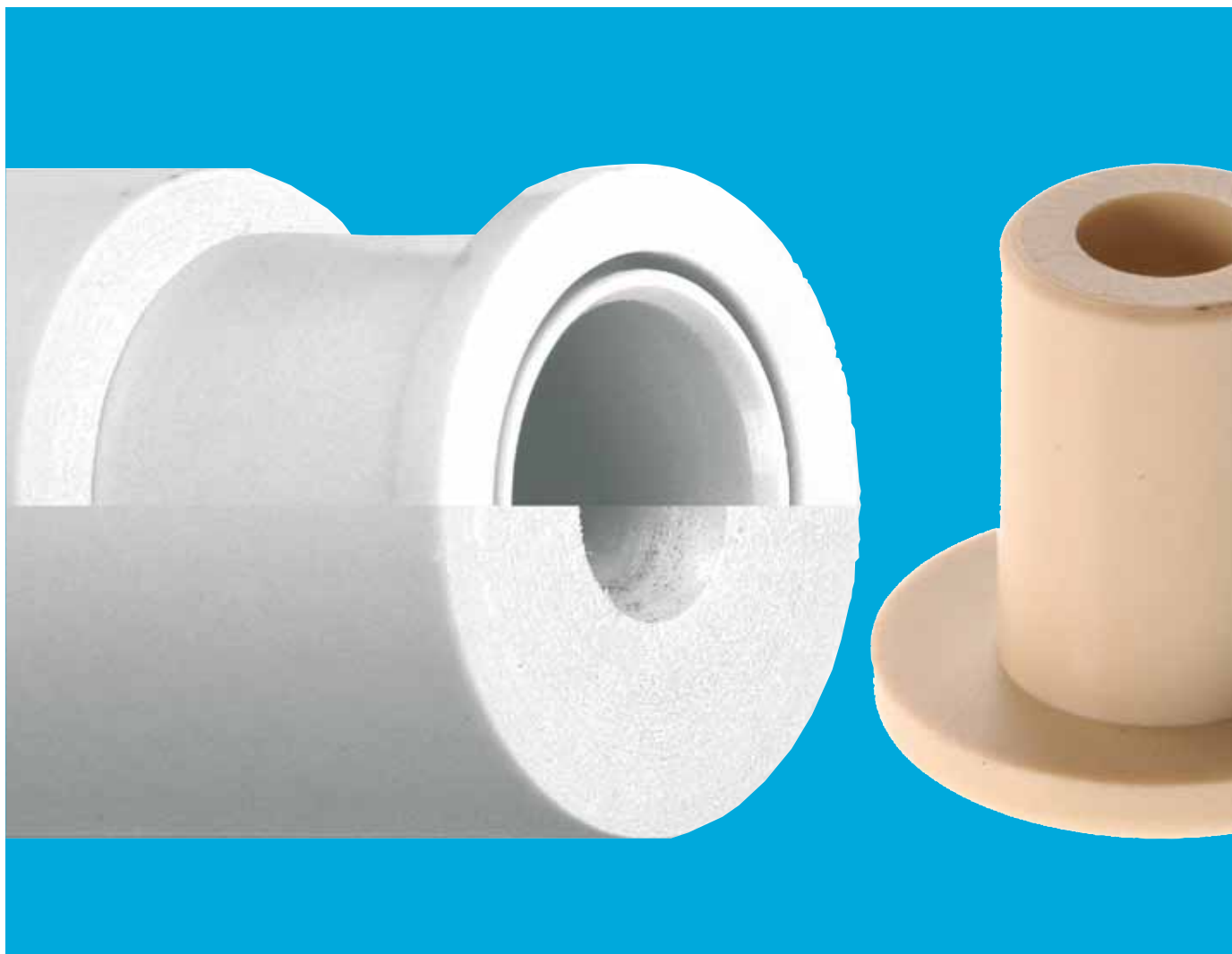

iglidur® Stock Bars and speedigus



Standard range from stock

iglidur® materials as round material or
customized molded parts

Maintenance-free and predictable service life

Fast delivery and low priced



iglidur® Stock Bars and speedigus | Own design

iglidur® gives design freedom – now available as round material, mechanically finished special parts or customized moulded parts – for prototypes, test samples and low volume requirements.

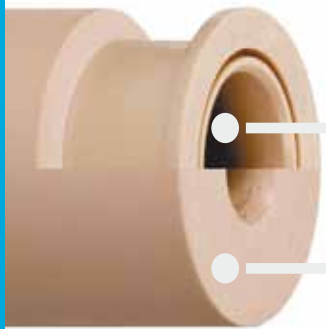

iglidur® materials as
round material or
customized molded parts

Maintenance-free and
predictable service life



fast delivery
and low priced



When to use it?

- If the required dimension is not in iglidur® catalog range
- If you need a stock bar with excellent wear rates and coefficient of friction
- If you need only a small size from iglidur® special parts
- If you need to make a prototype using iglidur® bearings



When not to use it?

- If an equal iglidur® standard catalog bearing is available
- If you need a iglidur® plain bearings with special dimensions in high quantity
▶ Please ask us
- If you need a stock bar without any tribological properties



Material data for stock bars

- iglidur® A180 ▶ page 371
- iglidur® J ▶ page 89
- iglidur® J4 ▶ page 982
- iglidur® P210 ▶ page 982
- iglidur® R ▶ page 249
- iglidur® W300 ▶ page 131



Material data for speedigus

- iglidur® G ▶ page 61
- iglidur® J ▶ page 89
- iglidur® M250 ▶ page 107
- iglidur® W300 ▶ page 131
- iglidur® X ▶ page 153
- iglidur® A180 ▶ page 371
- iglidur® H2 ▶ page 359
- iglidur® P ▶ page 185
- igumid G ▶ page 983

Temperatures

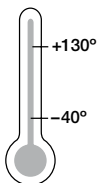

iglidur® G

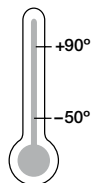

iglidur® J

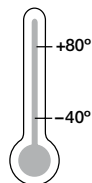

iglidur® M250

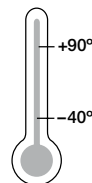

iglidur® W300

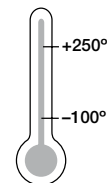

iglidur® X

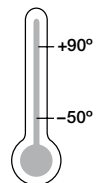

iglidur® A180

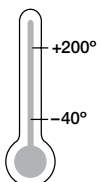

iglidur® H2

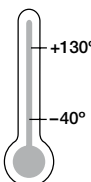

iglidur® P

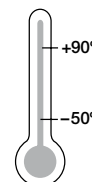

iglidur® J4

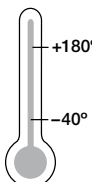

iglidur® P210

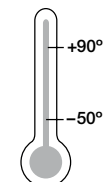

iglidur® R



iglidur® Stock Bars | Product Range



Order key

SFRJ-3000-500



Length*
Inner diameter
(00 = solid material)
Outer diameter
iglidur® J Material
round
iglidur® stock bar
(semi-finished)

Dimensions [mm]

Part number	Ø	Material
SFRW-3000- <input type="text"/> *	30	iglidur® W300
SFRW-6000- <input type="text"/> *	60	iglidur® W300

Part number	Ø	Material
SFRJ-1000- <input type="text"/> *	10	iglidur® J
SFRJ-2000- <input type="text"/> *	20	iglidur® J
SFRJ-3000- <input type="text"/> *	30	iglidur® J
SFRJ-4000- <input type="text"/> *	40	iglidur® J
SFRJ-5000- <input type="text"/> *	50	iglidur® J
SFRJ-6000- <input type="text"/> *	60	iglidur® J
SFRJ-8000- <input type="text"/> *	80	iglidur® J
SFRJ-10000- <input type="text"/> *	100	iglidur® J

* length in mm from 100 to 1000 graduated in 100 mm steps

** new in this catalog

Use the online product selector to input application parameters, add to shopping basket, and order

► www.igus.co.uk/stockbar-productfinder

Part number	Ø	Material
SFRA180-1000- <input type="text"/> *	10	iglidur® A180
SFRA180-2000- <input type="text"/> *	20	iglidur® A180
SFRA180-3000- <input type="text"/> *	30	iglidur® A180
SFRA180-4000- <input type="text"/> *	40	iglidur® A180
SFRA180-5000- <input type="text"/> *	50	iglidur® A180
SFRA180-6000- <input type="text"/> *	60	iglidur® A180
SFRA180-8000- <input type="text"/> *	80	iglidur® A180
SFRA180-10000- <input type="text"/> *	100	iglidur® A180

Part number	Ø	Material
SFRJ4-3000- <input type="text"/> *	30	iglidur® J4

Part number	Ø	Material
SFRP210-3000- <input type="text"/> *	30	iglidur® P210

Part number	Ø	Material
SFRR-3000- <input type="text"/> *	30	iglidur® R

delivery time available from stock

prices price list online www.igus.co.uk/stockbar

order part number **example** SFRJ-1000

What is speedigus? Simple; choose any iglidur® material, get moulded parts in 1 to 10 days, depending on complexity of the part. Full technical component information given with every quotation, including leadtime options. Absolute maximum delivery is 15 days.



How speedigus works?

- 1 Tell us about your special part: material, special requirements etc. and upload or email us your 3D model
- 2 Check your speedigus quotation, select your required leadtime, then place your order
- 3 The speedigus tool for your part is manufactured
- 4 The parts are moulded in the igus® material which you have selected
- 5 You fit your parts

Choose your speedigus material

Your requirements

<input type="checkbox"/> Maximum service life in dry operation	<input type="checkbox"/> Low coefficients of friction	max. static surface pressure (23°C) 0 Mpa
<input type="checkbox"/> Dirt resistant	<input type="checkbox"/> High resistance to chemicals	Upper long-term application temperature 20 °C
<input type="checkbox"/> Vibration dampening	<input type="checkbox"/> Good in misalignment	Lower application temperature 0 °C
<input type="checkbox"/> Low moisture absorption	<input type="checkbox"/> Underwater application	
<input type="checkbox"/> FDA compatible/ Foodstuff	<input type="checkbox"/> Cost effective	
<input type="checkbox"/> E-Chain® components		

The iglidur® bearing suited for you:

iglidur G3	iglidur P	iglidur M200	iglidur VV20	iglidur X	iglidur A100
iglidur P	iglidur L10	iglidur G			

iglidur G3 The best solution within the iglidur® bearings production range
iglidur P iglidur® material with good suitability for your requirement

Speediquote

Tell us what material you would like your part made in, and upload a 3D model (preferably a STEP file).

Quantity required:

3D model of your part

Here you can upload data with a total volume of 10 MB.

File 1:

File 2:

File 3:

File 4:

File 5:

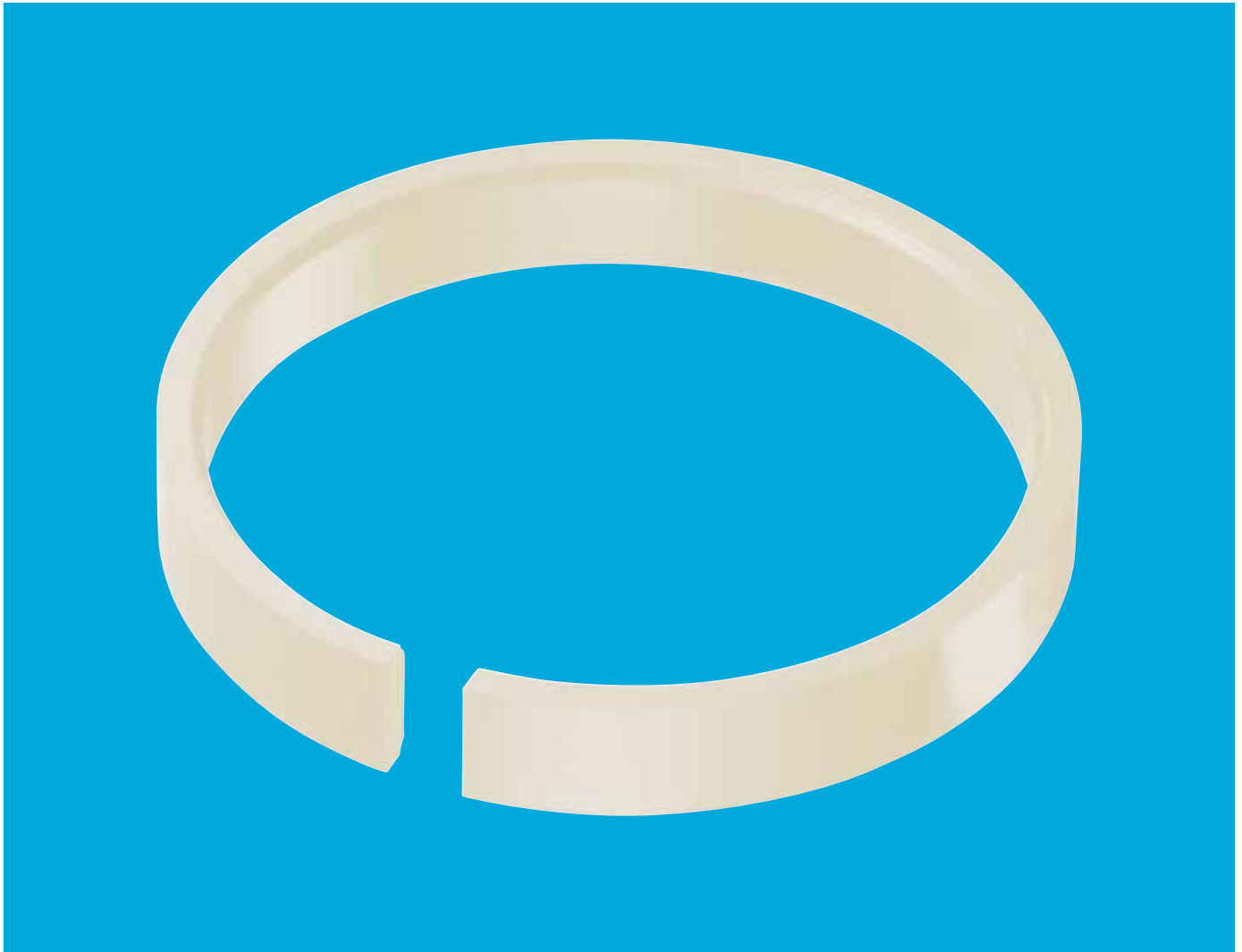

iglidur® Piston Rings



Standard range from stock

Easy installation

Economically

More wear-resistant than PTFE-strips

High load capacity

Wide dimensional range

iglidur® Piston Rings

Why complicate things when it can be done simply? It can actually be very easy: Replace complex stamped PTFE tapes with a single clip-on guide ring, for example in cylinders, control valves and fittings. We offer iglidur® piston rings made of any iglidur® material for a wide range of applications.



When to use it?

- When piston rings with excellent wear properties are required
- When simple assembly is of great importance
- When high edge loads occur
- When tailor-made solutions based on iglidur® materials are required



When not to use it?

- When the piston rings should also act as a seal
- When different diameters should be covered by one part

Traditional method:

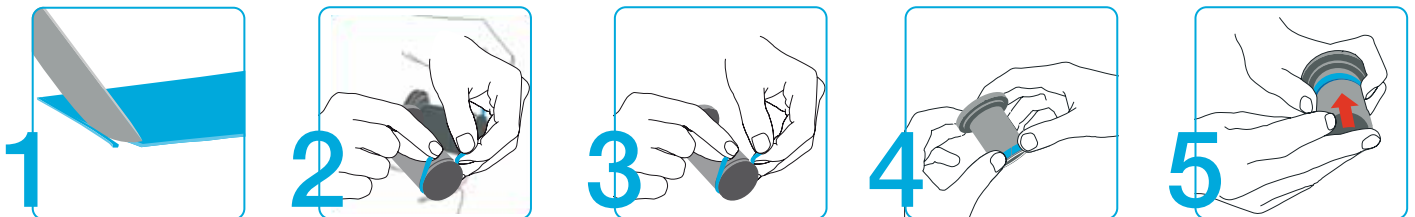

New: with iglidur®:

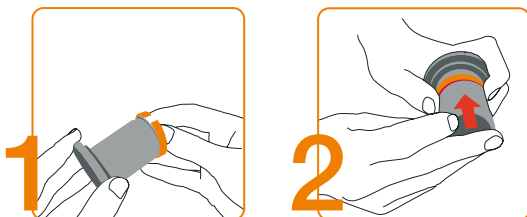

Product range

Ø 10–70 mm
more dimensions on request



NEW in this catalog!

iglidur® Piston Rings | Product Range

iglidur®
piston
rings



Order key

JPRM-1012-054



Length
Outer diameter
Inner diameter
Metric
Piston rings
iglidur® J

iglidur® J piston rings, from stock

Dimensions [mm]

Part number	Inner-Ø d1	Outer-Ø d2	Width piston ring b1; h13	Gap width	Tolerance gap ±mm	Split angle [°]
JPRM-1012-054	10	12	5.4	2.5	0.5	20
JPRM-1214-054	12	14	5.4	2.5	0.5	20
JPRM-1416-054	14	16	5.4	2.5	0.5	20
JPRM-1618-054	16	18	5.4	2.5	0.5	20
JPRM-2023-054	20	23	5.4	2.5	0.5	20
JPRM-2528-054	25	28	5.4	2.5	0.5	20
JPRM-3034-054	30	34	5.4	2.5	0.5	20
JPRM-3539-054	35	39	5.4	2.5	0.5	20
JPRM-4044-054	40	44	5.4	2.5	0.5	20
JPRM-4550-054	44	50	5.4	2.5	0.5	20
JPRM-5055-054	50	55	5.4	2.5	0.5	20
JPRM-6065-054	60	65	5.4	2.5	0.5	20
JPRM-7075-054	70	75	5.4	2.5	0.5	20

Custom-made piston rings

Piston rings in your required material and dimensions in max. 10 days from the entire iglidur® bearings catalog program – economically injection molded and processed in your required dimensions.

Preferable iglidur® materials:

- iglidur® J: universal ► page 89
- iglidur® A180: FDA conform ► page 371
- iglidur® J4 ► page 982
- iglidur® J350: > +90 °C ► page 229
- iglidur® X: chemicals, temperatures ► page 153

Choose your material and diameter from the igus® bearing catalog, tell us your required length and done.



Order key

□PRM-d1d2-b1



b1: Required length
Inner- and Outer-Ø
(d1 + d2)
from available standard
plain bearing
Metric
Piston rings
iglidur® material



delivery available
time from stock



prices price list online
www.igus.co.uk/pistonring



order part number
example JPRM-1012-054

