

FYH[®]

CERABALL SERIES

Hybrid Bearing Units for Special Environments



CATALOG NO.4000E



CERABALL SERIES

The Ceraball series exhibits extremely high anti-abrasion qualities and offers remarkably stable performance in the most severe environments.

In 1984, for the first time in Japan, FYH succeeded in the production of total ceramic bearings from start-to-finish production of raw materials. Since that time, user feedback has confirmed that this series has proven itself as the ultimate choice for a multitude of special operating environments. After more than two decades of continual development, this series has been evaluated as "the most reliable maintenance-free bearing" for any industry, and it has evolved to include a variety of options to satisfy many specific needs.

The ceramic balls and precision inner and outer rings of the Ceraball bearing demonstrate excellent wear resistance and provide longevity and stable performance in applications where temperature extremes, high speed, torque, and corrosion are factors.

Ceraball features

- **Reduced maintenance costs**
Re-lubrication intervals can be significantly extended or eliminated altogether.
- **Green bearings**
Excessive grease discharge can be eliminated thereby contributing to a cleaner environment.
- **Independent operation**
Supplementary items such as cooling devices and automatic grease replenishment systems can be eliminated.
- **Low friction**
Low friction operation reduces the amount of energy required thereby saving electricity and money.
- **High stress resistance**
The threat of shattering from foreign matter incursion is greatly reduced which creates a safer working environment.
- **Non-conductive**
Electric arcing is eliminated.

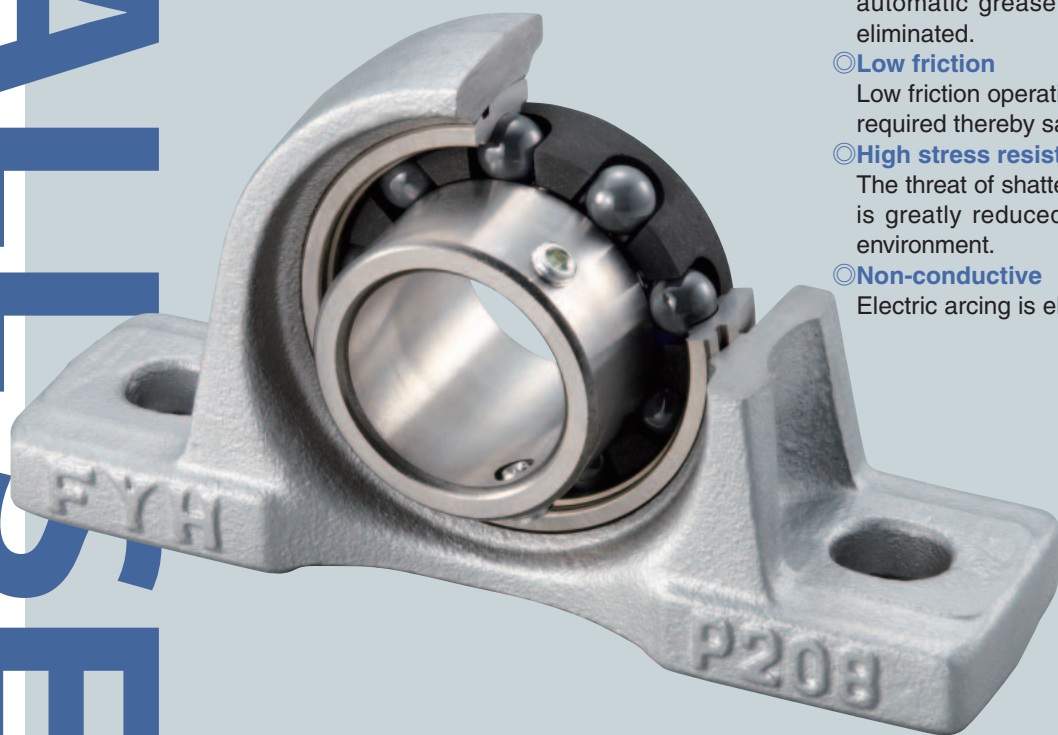

Ceramic bearing material of the FYH-SN series



Material property of FYH-SN	FYH-SN	Bearing steel
Heat resistance (temperature, °C)	800	180
Density (g/cm ³)	3.2	7.8
Bending strength (MPa)	1200	≥2500
Hardness (Hv)	1400 or more	750
YANG's modulus of elasticity (GPa)	320	210
Coefficient of thermal expansion (x 10 ⁻⁶ /°C)	3.3	12.5
Fracture toughness (MPa·m ^{1/2})	6.0 or more	18

FYH[®] silicon nitride ball production process

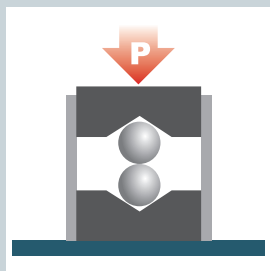
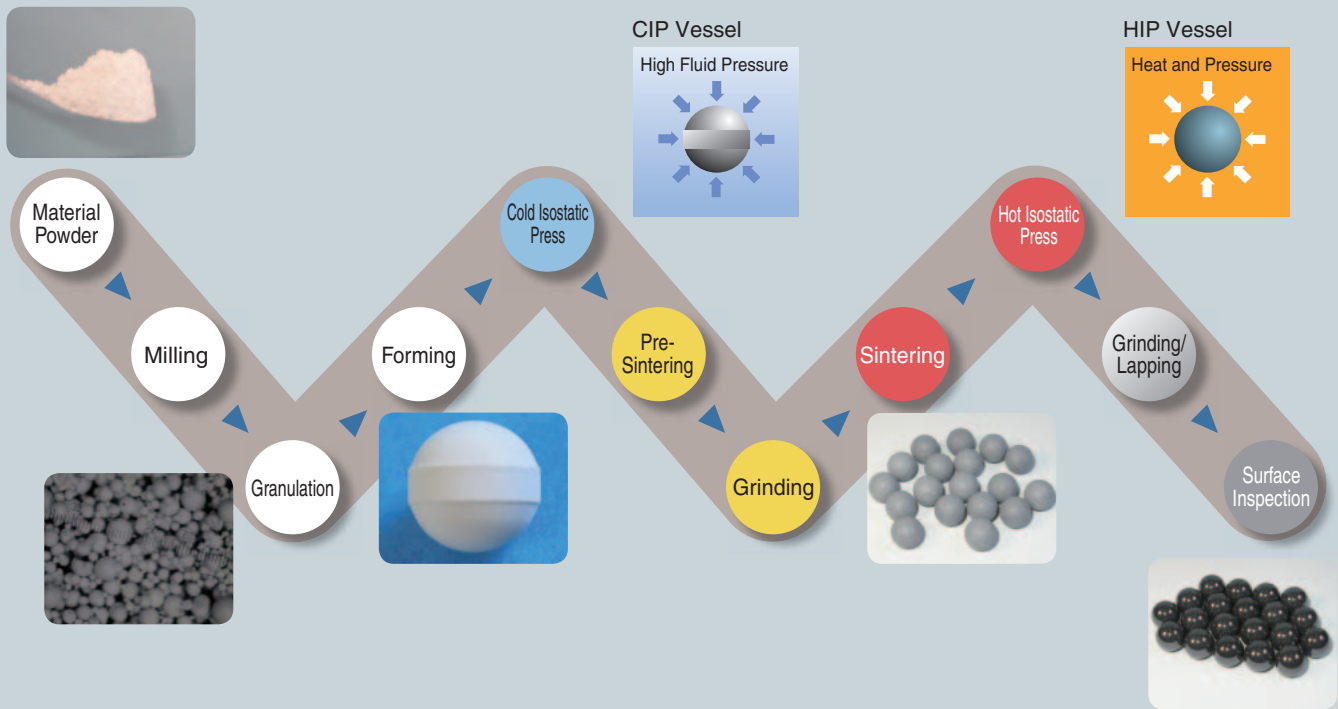

Ceramic Ball Crush Test

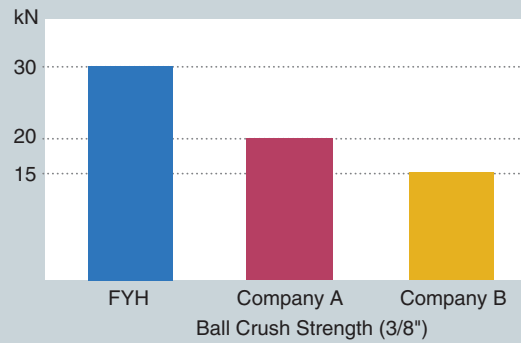

FYH has established a superior production process from mixing ingredients to molding, sintering, and processing. Compared with silicon nitride balls produced by other manufacturers, we are proud of the overwhelming high strength of the Ceraball, and we can promise consistently high quality, better product performance, and longer life.

Maintenance cost reduction example on a heat-treatment furnace

Heat treatment furnace

Standard unit



The standard unit is re-lubricated with high-temperature grease every day and completely changed every six months.

Ceraball unit



The Ceraball unit operates for three years without re-lubrication.

Ceraball selection chart

Bearing units

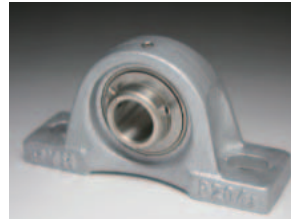

Bearings



Y1 type

Y2 type

Y3 type

Operating Environment	Type	Bearing Suffix Code	Specifications					
			Inner/Outer Ring	Ball	Retainer	Lubricant Type		
High Temp	Max Operating Temperature 180° C (356° F)	Y1	D9K6Y1	High-carbon chromium bearing steel	FYH-SN Silicon nitride ceramic	Stainless steel or Steel Corrugated retainer	Grease fluorochemical	
	Max Operating Temperature 230° C (446° F)	Y2	D9K6S6Y2	Martensitic stainless steel	FYH-SN Silicon nitride ceramic	Stainless steel Corrugated retainer	Grease fluorochemical	
	Max Operating Temperature 260° C (500° F)	Y2	D9P4S6Y2					
	Max Operating Temperature 450° C (842° F)	Y3	S6Y3	Martensitic stainless steel	FYH-SN Silicon nitride ceramic	Self-lubricating material		
High Speed	Ambient Atmospheric Conditions	Y1	D7(LS)S5Y1	High-carbon chromium bearing steel	FYH-SN Silicon nitride ceramic	Stainless steel or Steel Corrugated retainer	Grease for High speed	
	High Temp 260° C (500° F)	Y2	D9K3.6S6C3Y2	Martensitic stainless steel	FYH-SN Silicon nitride ceramic	Stainless steel Corrugated retainer	Grease fluorochemical	
Vacuum	Normal to High-temp Conditions Max 200° C (392° F)	Y2	D9K6S6Y2	Martensitic stainless steel	FYH-SN Silicon nitride ceramic	Stainless steel Corrugated retainer	Grease fluorochemical	
	High-temp Max 400° C (752° F)	Y3	S6Y3	Martensitic stainless steel	FYH-SN Silicon nitride ceramic	Self-lubricating material		
Corrosion Resistance	Acid / alkali liquid or vapor atmosphere	Y7	Y7	Precipitation hardening Stainless steel	FYH-SN Silicon nitride ceramic	Fluororesin or Stainless steel Corrugated retainer	—	
	Water, pure water, high humidity	Y8	Y8	PEEK plastic	FYH-SN Silicon nitride ceramic	Fluororesin	—	
Clean	Normal temp - Mid temp	Y2	D9K6S6Y2	Martensitic stainless steel	FYH-SN Silicon nitride ceramic	Stainless steel Corrugated retainer	Grease fluorochemical	
	High temp	Y3	S6Y3	Martensitic stainless steel	FYH-SN Silicon nitride ceramic	Self-lubricating material		

* If your application is not specified above or if you require different specifications, please use the attached form to detail your application and additional requests. Dimensional data subject to change without notice. Please confirm all dimensions and specifications before ordering.

◎ Part Number for Ordering

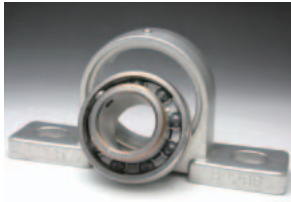

Y7 type



Y8 type

Bearing Units	Unit No. UCP206	+	Bearing Suffix Code D9K6S6Y2
---------------	--------------------	---	---------------------------------

Deep Groove Ball Bearings	Bearing No. 6206ZZ	+	Bearing Suffix Code D9S6Y2
---------------------------	-----------------------	---	-------------------------------

Seal			Slinger	Housing	Feature	Example Application	
Fluoroelastomer	Austenitic Stainless steel or Steel	Cast iron	Standard bearings operating in excessively high/low-temperature conditions, or in environments where liquids or gasses are present, require a great deal of maintenance and monitoring, and they are often subject to sudden failure. Ceraball bearings incorporating fluorinated grease (operating range: -60 to 260°C (-76 to 500°F)) allow for extended lubrication intervals and longer life.		Heat-resistant blower Spray granulating machine Press & rewinding light torque		
Fluoroelastomer	Austenitic Stainless steel	Cast iron (heat-resistant paint) or Stainless steel			When liquids or gasses are present in higher concentrations, standard bearings operating in temperatures above 180°C (356°F) can deteriorate from surface oxidation rather quickly. The Ceraball series can be incorporated into stainless steel bearings to prevent rapid corrosion. If the operating temperature exceeds 230°C (446°F) then seals are omitted and only slingers (Z-seal) are utilized.		Food equipment Wash-down Heat treatment furnace With a low reactor Drying Furnace Glass Production Line
—	Austenitic Stainless steel	Cast iron (heat-resistant paint) or Stainless steel					Standard bearings utilizing grease as a lubricant cannot function well above 260°C (500°F). FYH has developed a solid self-lubricating lubricant which can operate in temperatures over 450°C (842°F) particularly at lower RPM's > dn 5,000.
Nitrile	Austenitic Stainless steel or Steel	Cast iron	High speed applications produce a great deal of centrifugal force which is further increased by standard steel balls. The specific gravity of the Ceraball is 3.2 which is less than half of a steel ball's specific gravity of 7.8. With about 40% of the load, the effects of centrifugal force are reduced and the life of the Ceraball bearing is greatly extended.		Heat-resistant blower		
Fluoroelastomer	Austenitic Stainless steel	Cast iron (heat-resistant paint) or Stainless steel			When operating in a vacuum, base oils often evaporate from the grease and deterioration of the lubricant occurs. Because high-quality fluorinated grease is used, which is enclosed by fluorine seals within the ball path, this problem is eliminated. The Ceraball provides stable performance to 10 ⁻⁵ Pa under normal atmospheric temperatures.		Vacuum Equipment
—	Austenitic Stainless steel	Cast iron (heat-resistant paint) or Stainless steel	The self-lubricating solid lubrication system functions very well at a wide range of temperatures, and it is well-suited to vacuum-based machinery.				Sputtering system
—	—	Stainless steel			For particularly strong solid, liquid, or vapor based acids and bases, FYH has adopted a separation hardened stainless steel for the inner and outer rings as well as the Y7 ceramic series that incorporates a special corrosion resistant ceramic ball originally developed by FYH.		Film / chemical production
—	—	—	Where severe corrosion, metal abrasion, and rust are concerns, polyetheretherketone (PEEK) plastic inner and outer rings are employed as well as the Y8 ceramic series that incorporates a special corrosion resistant ceramic ball. It is usually used in the condition of a very light load.				Silicon wafer production Ultrapure water
Fluoroelastomer	Austenitic Stainless steel	Cast iron (heat-resistant paint) or Stainless steel			Special contaminate-free environments require clean-operating components. Because it needs less grease, the Ceraball can meet these requirements and, through a wide range of temperatures, it releases much less debris than conventional bearings. High-temperature applications requiring solid graphite lubricant may discharge only a small amount of graphite.		IC manufacturing-related equipment Food Equipment
—	Austenitic Stainless steel	Cast iron (heat-resistant paint) or Stainless steel	—				—

Ceraball model number table

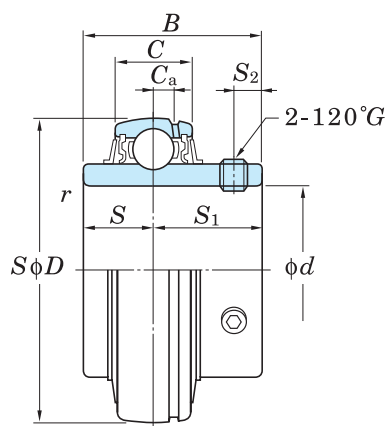

UC type

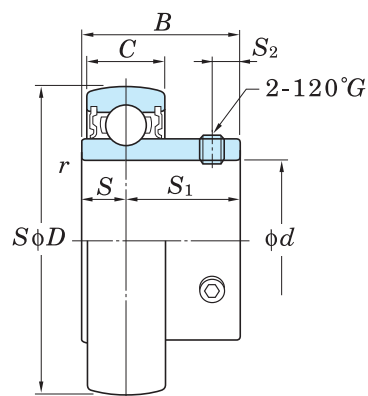

SU type

Bearing No.	Nominal bore diameter d	Dimensions (mm)									Production Range			
		D	C	B	S	S_1	r	C_a	S_2	G	Y1	Y2	Y3	Y7
SU08	8	22	7	12	3.5	8.5	0.3	—	2.8	M3×0.35	◎			
SU000	10	26	8	15	5	10	0.3	—	3	M3×0.35	◎	◎		
SU001	12	28	8	15	5	10	0.3	—	3	M3×0.35	◎	◎		
UC201X	12	40	13	27.4	11.5	15.9	1	3	4	M5×0.5		◎	◎	
UC201	12	47	16	31	12.7	18.3	1	4	5	M6×0.75	◎			
SU002	15	32	9	16.5	5.5	11	0.3	—	3.3	M4×0.5	◎	◎		
UC202X	15	40	13	27.4	11.5	15.9	1	3	4	M5×0.5		◎	◎	
UC202	15	47	16	31	12.7	18.3	1	4	5	M6×0.75	◎			
SU003	17	35	10	17.5	6	11.5	0.3	—	3.3	M4×0.5	◎	◎		
UC203X	17	40	13	27.4	11.5	15.9	1	3	4	M5×0.5		◎	◎	
UC203	17	47	16	31	12.7	18.3	1	4	5	M6×0.75	◎			
SU004	20	42	12	21	7	14	0.6	—	4	M5×0.5	◎	◎		
UC204	20	47	16	31	12.7	18.3	1.5	4	5	M6×0.75	◎	◎	◎	◎
SU005	25	47	12	22	7	15	0.6	—	4.5	M5×0.5	◎	◎		
UC205	25	52	17	34	14.3	19.7	1.5	3.5	5.5	M6×0.75	◎	◎	◎	◎
SU006	30	55	13	24.5	7.5	17	1	—	5.5	M5×0.5	◎	◎		
UC206	30	62	19	38.1	15.9	22.2	1.5	4.5	6	M6×0.75	◎	◎	◎	◎
UC207	35	72	20	42.9	17.5	25.4	2	4.5	6.5	M8×1	◎	◎	◎	
UC208	40	80	21	49.2	19	30.2	2	4.5	8	M8×1	◎	◎	◎	◎
UC209	45	85	22	49.2	19	30.2	2	5	8	M8×1	◎	◎	◎	
UC210	50	90	24	51.6	19	32.6	2	6	9	M10×1.25	◎	◎	◎	
UC211	55	100	25	55.6	22.2	33.4	2.5	5.5	9	M10×1.25	◎	◎	◎	
UC212	60	110	27	65.1	25.4	39.7	2.5	6	10.5	M10×1.25	◎	◎	◎	
UC213	65	120	28	65.1	25.4	39.7	2.5	6.5	12	M12×1.5	◎			
UC214	70	125	30	74.6	30.2	44.4	2.5	6	12	M12×1.5	◎			
UC215	75	130	32	77.8	33.3	44.5	2.5	7	12	M12×1.5	◎			
UC216	80	140	33	82.6	33.3	49.3	3	7.5	14	M12×1.5	◎			
UC217	85	150	35	85.7	34.1	51.6	3	7.5	14	M12×1.5	◎			
UC218	90	160	38	96	39.7	56.3	3	8	15	M12×1.5	◎			

◎: Stock model

Refer to the latest FYH general catalog for mounting configurations and additional housing options.

Dimensional data subject to change without notice. Please confirm all dimensions and specifications before ordering.

Ceraball model number table

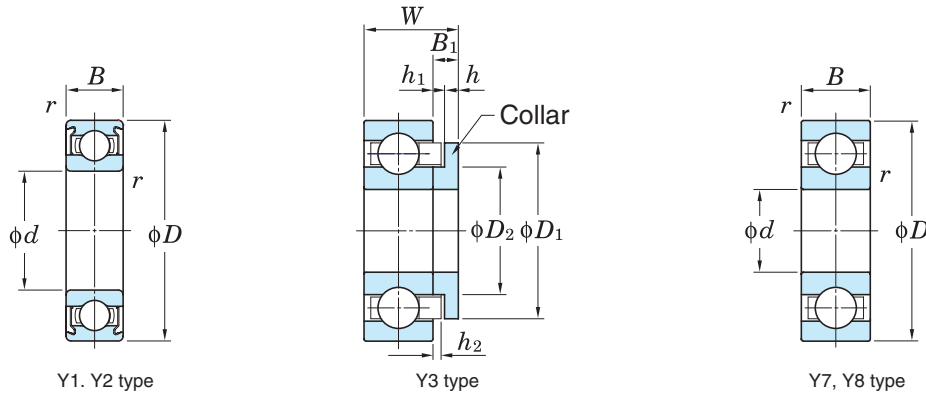

Bearing No.	Nominal bore diameter d	Dimensions (mm)									Production Range				
		D	B	r	h_2	D_1	D_2	h	B_1	W	Y1	Y2	Y3	Y7	Y8
608	8	22	7	0.3	1.18	17.7	12.1	3.0	4.6	11.6	*	⊙	⊙	*	*
6000	10	26	8	0.3	1.58	20.6	14.2	3.0	5.0	13.0	*	⊙	⊙	*	⊙
6200	10	30	9	0.6	1.08	23.0	17.6	3.0	4.5	13.5	*	⊙	⊙	*	*
6001	12	28	8	0.3	1.58	23.3	17.2	3.0	5.1	13.1	*	⊙	⊙	*	⊙
6201	12	32	10	0.6	1.18	25.5	18.5	3.0	4.7	14.7	*	⊙	⊙	*	*
6002	15	32	9	0.3	1.28	26.0	20.2	3.0	4.8	13.8	*	⊙	⊙	*	⊙
6202	15	35	11	0.6	0.68	28.5	21.7	3.0	4.2	15.2	*	⊙	⊙	*	*
6003	17	35	10	0.3	0.78	29.0	23.5	3.0	4.3	14.3	*	⊙	⊙	*	⊙
6203	17	40	12	0.6	1.07	32.6	24.9	3.0	4.6	16.6	*	⊙	⊙	*	*
6004	20	42	12	0.6	0.98	34.8	27.6	3.0	4.5	16.5	*	⊙	⊙	⊙	⊙
6204	20	47	14	1	0.37	39.0	29.5	3.0	3.9	17.9	*	⊙	⊙	⊙	*
6005	25	47	12	0.6	0.88	39.5	31.7	3.0	4.5	16.5	*	⊙	⊙	⊙	⊙
6205	25	52	15	1	0.37	43.6	34.0	3.0	4.0	19.0	*	⊙	⊙	⊙	*
6006	30	55	13	1	1.27	46.0	38.0	4.0	5.9	18.9	*	⊙	⊙	⊙	*
6206	30	62	16	1	0.96	52.0	40.7	4.0	5.6	21.6	*	⊙	⊙	⊙	*
6007	35	62	14	1	1.67	53.2	44.0	4.0	6.3	20.3	*	⊙	⊙	*	⊙
6207	35	72	17	1.1	1.76	60.7	47.6	4.0	6.4	23.4	*	⊙	⊙	⊙	*
6008	40	68	15	1	1.27	58.8	49.2	4.0	5.9	20.9	*	⊙	⊙	*	*
6208	40	80	18	1.1	2.15	66.8	52.9	4.0	6.8	24.8	*	⊙	⊙	⊙	*
6009	45	75	16	1	1.57	64.5	54.5	4.0	6.3	22.3	*	⊙	⊙		*
6209	45	85	19	1.1	2.55	71.0	56.5	4.0	7.3	26.3	*	⊙	⊙		*
6010	50	80	16	1	1.27	58.8	49.2	4.0	5.9	21.9	*	⊙	⊙		*
6210	50	90	20	1.1	2.15	66.8	52.9	4.0	6.8	26.8	*	⊙	⊙		*
6211	55	100	21	1.5	3.34	86.5	70.4	4.0	8.2	29.2	*	⊙	⊙		
6212	60	110	22	1.5	6.64	95.0	77.7	4.0	11.5	33.5	*	*	*		

⊙: Stock model * : Contact FYH for availability.

Additional styles and sizes may be available including 6300, 6800, 6900, 600, 620, and thrust bearings. Contact FYH for availability.

Dimensional data subject to change without notice. Please confirm all dimensions and specifications before ordering.

