

BARDEN

Double Direction Angular Contact Thrust
Ball Bearings and Cylindrical Roller Bearings



BARDEN
PRECISION
BEARINGS

INTRODUCTION



Barden manufactures super precision machine tool spindle bearings and instrument bearings at plants located in Danbury, Connecticut (shown above) and the U.K.

TABLE OF CONTENTS

Introduction	2
Double Direction Angular Contact Thrust Ball Bearings	3
Product Description and Engineering Notes	4
Nomenclature	5
Bearing Specification Tables	6-8
Cylindrical Roller Bearings	9
Product Description and Engineering Notes	10
Nomenclature	11
Bearing Specification Tables	12-15

The Barden Corporation is pleased to announce the availability of double direction angular contact thrust ball bearings and cylindrical roller bearings. These rugged, high load capacity machine tool spindle bearings are being manufactured by a subsidiary of our Aircraft and Super Precision Division, in Germany.

This new Barden product line complements an already extensive offering of super-precision, angular contact and deep groove ball bearings. It also gives users the ability to satisfy more machine tool spindle bearing requirements from a single source.

Both the double direction angular contact thrust ball bearings and cylindrical roller bearings feature a much higher level of rigidity for applications requiring exceptional performance under extreme loads. Special crown profile on rollers optimizes load distribution.

For application questions or ordering information, contact your Authorized Barden Distributor, or call 1-800-243-1060.

DOUBLE DIRECTION ANGULAR CONTACT THRUST BALL BEARINGS



DOUBLE DIRECTION ANGULAR CONTACT THRUST BALL BEARING

Double direction angular contact thrust ball bearings are designed for use in machine tool spindles, in combination with cylindrical roller bearings. They are manufactured to precision tolerances. Double direction angular contact thrust ball bearings are designed to carry only thrust loads. They match the mounting dimensions of the NN30 Series double row cylindrical roller bearings.

EXTERNAL DIMENSIONS

Double direction angular contact thrust ball bearings are designed to be mounted in conjunction with a double row radial cylindrical roller bearing. The nominal size of the external diameter is the same for both bearings which simplifies the machining of the housing bore. The external diameter tolerance of the double direction angular contact thrust ball bearing is designed so that there is clearance between the bearing O.D. and the housing bore. Use of this bearing type, in combination with a double row cylindrical roller bearing, offers the advantage of supporting both axial and radial forces separately.

BEARING DESIGN

Double direction angular contact thrust ball bearings have a contact angle of 60° and are axially preloaded. They are particularly well suited for running at high speeds. The contact angle and the axial preload ensures good ball control, especially under the centrifugal forces with fast rotating spindles. These bearings are designed to accommodate high thrust loads. They have solid one piece machined brass cages which are ball guided.

SPEEDABILITY

FAG double direction angular contact thrust ball bearings are ideally suited for high speeds. Speed limit values for grease and oil lubrication are given in the bearing tables on pages 6–8.

LUBRICATION

FAG double direction angular contact thrust ball bearings can be lubricated with either grease or oil. The outer ring O.D. has a lubricating groove in the center with lubricating holes. The application of the lubricant between the two rows of balls allows optimal distribution of lubricant to both raceways.

RIGIDITY

For optimum performance, machine tool spindle bearings must exhibit high rigidity as well as high precision. This means that they must run precisely and must allow only slight deflection under load. The double direction angular contact thrust ball bearings achieve high rigidity through their internal design with steep contact angle and internal defined preload (see table 1).

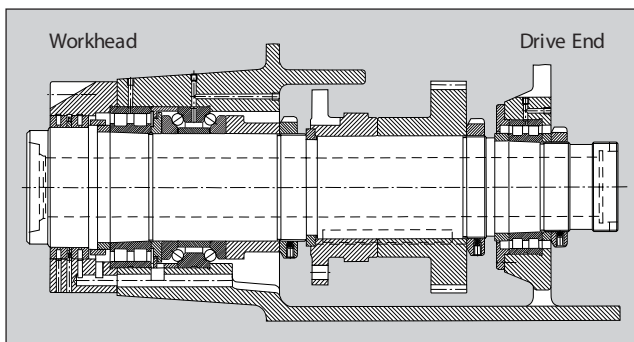

Fig. 1. This illustration of a milling spindle shows typical placement of a double direction angular contact thrust ball bearing used in combination with a double row cylindrical roller bearing in the workhead. The drive end of the spindle features one double row cylindrical bearing. This combination allows the spindle to operate at high speeds at high rigidity, while accommodating both axial and radial loads.

BEARING NOMENCLATURE



Example: 234410M.SP

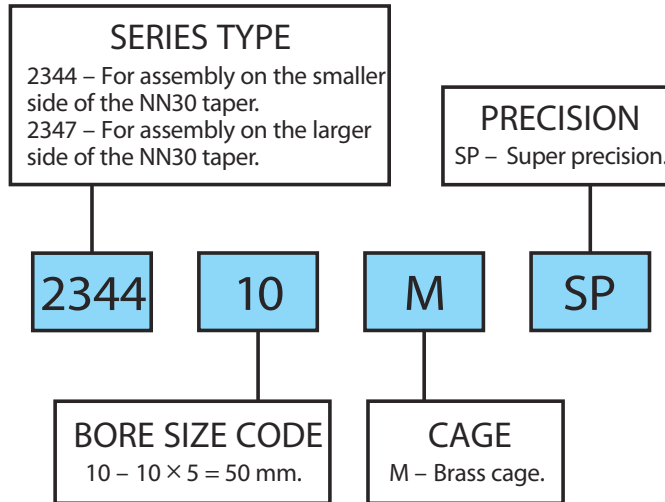

Table 1. Axial rigidity of double direction angular contact thrust ball bearings.

Bore Reference Number	S_a lb./ μ in.		Bore Reference Number	S_a lb./ μ in.
05	1.4		28	5.9
06	1.5		30	6.2
07	1.8		32	6.5
08	2.0		34	7.0
09	2.2		36	7.3
10	2.3		38	7.9
11	2.6		40	8.1
12	2.6		44	9.0
13	2.8		48	9.6
14	3.1		52	10.1
15	3.3		56	10.7
16	3.6		60	11.2
17	3.6		64	12.1
18	3.9		68	12.6
19	4.0		72	12.9
20	4.2		76	13.8
21	4.3		80	14.3
22	4.8			
24	5.1			
26	5.4			

$\delta_a = F_{ax}/S_a$ δ_r = axial deflection [μ in.] F_a = axial load [lb.] S_a = rigidity [lb./ μ in.]
These values apply up to an axial load equivalent to 2.2% of the dynamic capacity C.

DOUBLE DIRECTION ANGULAR CONTACT THRUST BALL BEARING

2344, 2347

• Contact angle = 60°

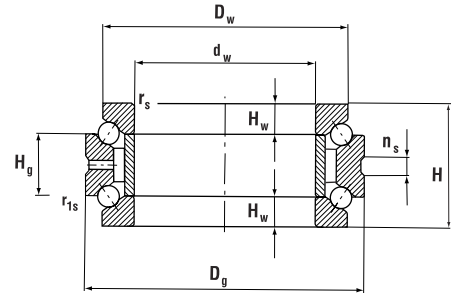

BEARING NUMBER	BEARING DIMENSIONS (in millimeters)									LOAD RATING		ATTAINABLE SPEED		WEIGHT
	dw	Dg	Dw	H	Hg	Hw	r _{smin}	r _{1smin}	ns	dyn. C	stat. C ₀	Grease rpm	Oil rpm	Weight ≈ lbs.
FAG										lbs.	lbs.			
234406M.SP	30	55	47	32	16	8	1	0.15	4.8	3,217	5,400	11,000	16,000	0.6
234706M.SP	32	55	47	32	16	8	1	0.15	4.8	3,217	5,400	11,000	16,000	0.6
234407M.SP	35	62	53	34	17	8.5	1	0.15	4.8	3,960	7,087	9,500	14,000	0.8
234707M.SP	37	62	53	34	17	8.5	1	0.15	4.8	3,960	7,087	9,500	14,000	0.8
234408M.SP	40	68	58.5	36	18	9	1	0.15	4.8	4,680	8,550	8,500	12,000	1.0
234708M.SP	42	68	58.5	36	18	9	1	0.15	4.8	4,680	8,550	8,500	12,000	0.9
234409M.SP	45	75	65	38	19	9.5	1	0.15	4.8	5,220	10,125	7,500	10,000	1.3
234709M.SP	47	75	65	38	19	9.5	1	0.15	4.8	5,220	10,125	7,500	10,000	1.2
234410M.SP	50	80	70	38	19	9.5	1	0.15	4.8	5,400	11,025	7,000	9,500	1.4
234710M.SP	52	80	70	38	19	9.5	1	0.15	4.8	5,400	11,025	7,000	9,500	1.3
234411M.SP	55	90	78	44	22	11	1.1	0.3	6.5	7,650	15,075	6,300	8,500	2.1
234711M.SP	57	90	78	44	22	11	1.1	0.3	6.5	7,650	15,075	6,300	8,500	1.9
234412M.SP	60	95	83	44	22	11	1.1	0.3	6.5	7,537	15,300	6,000	8,000	2.2
234712M.SP	62	95	83	44	22	11	1.1	0.3	6.5	7,537	15,300	6,000	8,000	2.1
234413M.SP	65	100	88	44	22	11	1.1	0.3	6.5	8,100	17,212	5,600	7,500	2.4
234713M.SP	67	100	88	44	22	11	1.1	0.3	6.5	8,100	17,212	5,600	7,500	2.2
234414M.SP	70	110	97	48	24	12	1.1	0.3	6.5	9,562	20,925	5,300	7,000	3.3
234714M.SP	73	110	97	48	24	12	1.1	0.3	6.5	9,562	20,925	5,300	7,000	3.0
234415M.SP	75	115	102	48	24	12	1.1	0.3	6.5	9,900	22,500	5,000	6,700	3.5
234715M.SP	78	115	102	48	24	12	1.1	0.3	6.5	9,900	22,500	5,000	6,700	3.2
234416M.SP	80	125	110	54	27	13.5	1.1	0.3	6.5	11,700	27,000	4,500	6,000	4.8
234716M.SP	83	125	110	54	27	13.5	1.1	0.3	6.5	11,700	27,000	4,500	6,000	4.4
234417M.SP	85	130	115	54	27	13.5	1.1	0.3	9.5	11,700	28,125	4,500	6,000	5.0
234717M.SP	88	130	115	54	27	13.5	1.1	0.3	9.5	11,700	28,125	4,500	6,000	4.6
234418M.SP	90	140	123	60	30	15	1.5	0.3	9.5	13,725	32,850	4,000	5,300	6.4
234718M.SP	93	140	123	60	30	15	1.5	0.3	9.5	13,725	32,850	4,000	5,300	6.0
234419M.SP	95	145	128	60	30	15	1.5	0.3	9.5	13,725	33,750	4,000	5,300	6.7
234719M.SP	98	145	128	60	30	15	1.5	0.3	9.5	13,725	33,750	4,000	5,300	6.2
234420M.SP	100	150	133	60	30	15	1.5	0.3	9.5	13,950	35,100	3,800	5,000	7.0
234720M.SP	103	150	133	60	30	15	1.5	0.3	9.5	13,950	35,100	3,800	5,000	6.5
234421M.SP	105	160	142	66	33	16.5	2	0.6	9.5	15,637	39,600	3,600	4,800	9.0
234721M.SP	109	160	142	66	33	16.5	2	0.6	9.5	15,637	39,600	3,600	4,800	8.2
234422M.SP	110	170	150	72	36	18	2	0.6	9.5	20,250	50,400	3,400	4,500	11.4
234722M.SP	114	170	150	72	36	18	2	0.6	9.5	20,250	50,400	3,400	4,500	10.6
234424M.SP	120	180	160	72	36	18	2	0.6	9.5	20,925	54,000	3,200	4,300	12.3

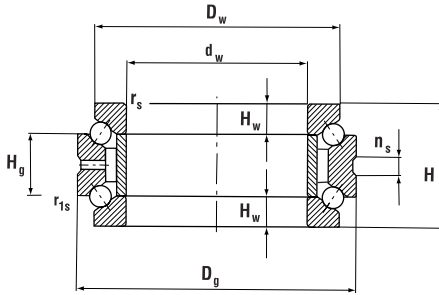

BEARING NUMBER	BEARING DIMENSIONS (in millimeters)									LOAD RATING		ATTAINABLE SPEED		WEIGHT
	dw	Dg	Dw	H	Hg	Hw	r _{smin}	r _{1smin}	n _s	dyn. C	stat. C ₀	Grease rpm	Oil rpm	Weight ≈ lbs.
FAG										lbs.	lbs.			
234724M.SP	124	180	160	72	36	18	2	0.6	9.5	20,925	54,000	3,200	4,300	11.3
234426M.SP	130	200	177	84	42	21	2	0.6	12.2	26,550	67,500	2,800	3,800	18.2
234726M.SP	135	200	177	84	42	21	2	0.6	12.2	26,550	67,500	2,800	3,800	16.7
234428M.SP	140	210	187	84	42	21	2.1	0.6	12.2	27,450	72,000	2,600	3,600	19.3
234728M.SP	145	210	187	84	42	21	2.1	0.6	12.2	27,450	72,000	2,600	3,600	17.8
234430M.SP	150	225	200	90	45	22.5	2.1	0.6	15	29,700	79,875	2,600	3,600	23.8
234730M.SP	155	225	200	90	45	22.5	2.1	0.6	15	29,700	79,875	2,600	3,600	21.9
234432M.SP	160	240	212	96	48	24	2.1	0.6	15	35,100	93,375	2,400	3,400	28.4
234732M.SP	165	240	212	96	48	24	2.1	0.6	15	35,100	93,375	2,400	3,400	26.4
234434M.SP	170	260	230	108	54	27	2.1	0.6	15	43,425	117,000	2,200	3,200	39.0
234734M.SP	176	260	230	108	54	27	2.1	0.6	15	43,425	117,000	2,200	3,200	35.9
234436M.SP	180	280	248	120	60	30	2.1	0.6	15	48,600	131,625	2,000	3,000	51.6
234736M.SP	187	280	248	120	60	30	2.1	0.6	15	48,600	131,625	2,000	3,000	47.3
234438M.SP	190	290	258	120	60	30	2.1	0.6	15	50,400	141,750	1,900	2,800	54.4
234738M.SP	197	290	258	120	60	30	2.1	0.6	15	50,400	141,750	1,900	2,800	49.8
234440M.SP	200	310	274	132	66	33	2.1	0.6	15	59,625	162,000	1,800	2,600	69.4
234740M.SP	207	310	274	132	66	33	2.1	0.6	15	59,625	162,000	1,800	2,600	64.3
234444M.SP	220	340	304	144	72	36	3	1.1	15	70,875	202,500	1,600	2,200	91.9
234744M.SP	228	340	304	144	72	36	3	1.1	15	70,875	202,500	1,600	2,200	84.9
234448M.SP	240	360	322	144	72	36	3	1.1	15	73,125	217,125	1,500	2,000	96.6
234748M.SP	248	360	322	144	72	36	3	1.1	15	73,125	217,125	1,500	2,000	89.1
234452M.SP	260	400	354	164	82	41	4	1.5	17.7	85,500	265,500	1,400	1,900	142.2
234752M.SP	269	400	354	164	82	41	4	1.5	17.7	85,500	265,500	1,400	1,900	131.6
234456M.SP	280	420	374	164	82	41	4	1.5	17.7	87,750	285,750	1,300	1,800	152.1
234756M.SP	289	420	374	164	82	41	4	1.5	17.7	87,750	285,750	1,300	1,800	140.7
234460M.SP	300	460	406	190	95	47.5	4	1.5	17.7	101,250	344,250	1,200	1,700	216.9
234760M.SP	310	460	406	190	95	47.5	4	1.5	17.7	101,250	344,250	1,200	1,700	201.1
234464M.SP	320	480	426	190	95	47.5	4	1.5	17.7	102,375	366,750	1,200	1,700	224.9
234764M.SP	330	480	426	190	95	47.5	4	1.5	17.7	102,375	366,750	1,200	1,700	209.2
234468M.SP	340	520	459	212	106	53	4	1.5	17.7	121,500	450,000	1,100	1,600	304.2
234768M.SP	350	520	459	212	106	53	4	1.5	17.7	121,500	450,000	1,100	1,600	284.4
234472M.SP	360	540	479	212	106	53	4	1.5	17.7	121,500	459,000	1,000	1,500	317.5
234772M.SP	370	540	479	212	106	53	4	1.5	17.7	121,500	459,000	1,000	1,500	297.6
234476M.SP	380	560	499	212	106	53	4	1.5	17.7	126,000	495,000	1,000	1,500	339.5
234776M.SP	390	560	499	212	106	53	4	1.5	17.7	126,000	495,000	1,000	1,500	317.5



**BARDEN
PRECISION
BEARINGS**

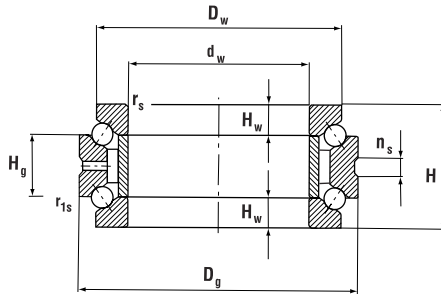

BEARING NUMBER	BEARING DIMENSIONS (in millimeters)									LOAD RATING		ATTAINABLE SPEED		WEIGHT
	d _w	D _g	D _w	H	H _g	H _w	r _{smin}	r _{1smin}	n _s	dyn. C	stat. C ₀	Grease rpm	Oil rpm	
FAG										lbs.	lbs.			
234724M.SP	124	180	160	72	36	18	2	0.6	9.5	20,925	54,000	3,200	4,300	11.3
234426M.SP	130	200	177	84	42	21	2	0.6	12.2	26,550	67,500	2,800	3,800	18.2
234726M.SP	135	200	177	84	42	21	2	0.6	12.2	26,550	67,500	2,800	3,800	16.7
234428M.SP	140	210	187	84	42	21	2.1	0.6	12.2	27,450	72,000	2,600	3,600	19.3
234728M.SP	145	210	187	84	42	21	2.1	0.6	12.2	27,450	72,000	2,600	3,600	17.8
234430M.SP	150	225	200	90	45	22.5	2.1	0.6	15	29,700	79,875	2,600	3,600	23.8
234730M.SP	155	225	200	90	45	22.5	2.1	0.6	15	29,700	79,875	2,600	3,600	21.9
234432M.SP	160	240	212	96	48	24	2.1	0.6	15	35,100	93,375	2,400	3,400	28.4
234732M.SP	165	240	212	96	48	24	2.1	0.6	15	35,100	93,375	2,400	3,400	26.4
234434M.SP	170	260	230	108	54	27	2.1	0.6	15	43,425	117,000	2,200	3,200	39.0
234734M.SP	176	260	230	108	54	27	2.1	0.6	15	43,425	117,000	2,200	3,200	35.9
234436M.SP	180	280	248	120	60	30	2.1	0.6	15	48,600	131,625	2,000	3,000	51.6
234736M.SP	187	280	248	120	60	30	2.1	0.6	15	48,600	131,625	2,000	3,000	47.3
234438M.SP	190	290	258	120	60	30	2.1	0.6	15	50,400	141,750	1,900	2,800	54.4
234738M.SP	197	290	258	120	60	30	2.1	0.6	15	50,400	141,750	1,900	2,800	49.8
234440M.SP	200	310	274	132	66	33	2.1	0.6	15	59,625	162,000	1,800	2,600	69.4
234740M.SP	207	310	274	132	66	33	2.1	0.6	15	59,625	162,000	1,800	2,600	64.3
234444M.SP	220	340	304	144	72	36	3	1.1	15	70,875	202,500	1,600	2,200	91.9
234744M.SP	228	340	304	144	72	36	3	1.1	15	70,875	202,500	1,600	2,200	84.9
234448M.SP	240	360	322	144	72	36	3	1.1	15	73,125	217,125	1,500	2,000	96.6
234748M.SP	248	360	322	144	72	36	3	1.1	15	73,125	217,125	1,500	2,000	89.1
234452M.SP	260	400	354	164	82	41	4	1.5	17.7	85,500	265,500	1,400	1,900	142.2
234752M.SP	269	400	354	164	82	41	4	1.5	17.7	85,500	265,500	1,400	1,900	131.6
234456M.SP	280	420	374	164	82	41	4	1.5	17.7	87,750	285,750	1,300	1,800	152.1
234756M.SP	289	420	374	164	82	41	4	1.5	17.7	87,750	285,750	1,300	1,800	140.7
234460M.SP	300	460	406	190	95	47.5	4	1.5	17.7	101,250	344,250	1,200	1,700	216.9
234760M.SP	310	460	406	190	95	47.5	4	1.5	17.7	101,250	344,250	1,200	1,700	201.1
234464M.SP	320	480	426	190	95	47.5	4	1.5	17.7	102,375	366,750	1,200	1,700	224.9
234764M.SP	330	480	426	190	95	47.5	4	1.5	17.7	102,375	366,750	1,200	1,700	209.2
234468M.SP	340	520	459	212	106	53	4	1.5	17.7	121,500	450,000	1,100	1,600	304.2
234768M.SP	350	520	459	212	106	53	4	1.5	17.7	121,500	450,000	1,100	1,600	284.4
234472M.SP	360	540	479	212	106	53	4	1.5	17.7	121,500	459,000	1,000	1,500	317.5
234772M.SP	370	540	479	212	106	53	4	1.5	17.7	121,500	459,000	1,000	1,500	297.6
234476M.SP	380	560	499	212	106	53	4	1.5	17.7	126,000	495,000	1,000	1,500	339.5
234776M.SP	390	560	499	212	106	53	4	1.5	17.7	126,000	495,000	1,000	1,500	317.5

CYLINDRICAL ROLLER BEARINGS



CYLINDRICAL ROLLER BEARINGS

Super precision cylindrical roller bearings are designated as Series N10 and NN30.

These double row bearings are typically used in combination with double direction angular contact thrust bearings in applications where radial stiffness, high radial capacity and high precision support is required. They represent the ideal solution for a floating bearing location, since they are internally adjusting (floating).

For axial loads, double direction angular contact thrust bearings, Series 2344 are used in combination with Series NN30 bearings.

A single row bearing would be most commonly used as the "floating" bearing in combination with a set of preloaded angular contact spindle bearings.

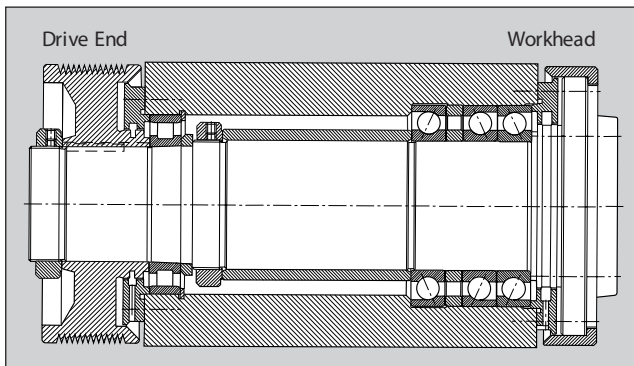

Fig. 2. Illustration shows a CNC lathe spindle with a single row cylindrical roller bearing used in the drive end. One single and one pair of angular contact balls bearings is used in the workhead end of the spindle. The combination provides high speed and precision machining capabilities with high radial load carrying capacity.

BEARING DESIGN

Double row cylindrical roller bearings have a high load carrying capacity because of the high number of cylindrical rollers in each row, and the exclusive optimized roller crown profile which results in the best load distribution.

The cage is of solid machined brass construction, making this bearing suitable for rugged applications.

Single row cylindrical roller bearings also have a solid brass cage and are specially designed for the demands of high speed spindles. These also feature rollers with an exclusive, optimized roller crown design.

The bearing bore is tapered (taper = 1: 12). The desired radial preload or radial clearance can be set by an axial adjustment on the conical shaft. Generally, the bearings should be mounted with zero clearance to a very slight preload.

SPEEDABILITY

Cylindricals generally have lower limiting speed than ball bearings. They are the limiting factor when used in conjunction with spindle bearings on the work end of a spindle.

LUBRICATION

FAG cylindrical roller bearings can be lubricated with either grease or oil.

Double row bearings feature a lubricating groove and lubricating hole in the middle of the outer ring.

RIGIDITY

Cylindrical roller bearings have a higher rigidity than comparable size angular contact ball bearings (see table 3).

Table 2. Radial play of FAG Cylindrical Roller Bearings with tapered bore.

Nominal bearing bore	Over to	Dimensions in mm																								
		30	30 40	40 50	50	65	65 80	80 100	100	120	120 140	140	160	160 180	180	200	200 225	225	250	250 280	280	315	315 355	355	400	400 450
Bearing Design		Radial play in μm																								
ASK.M.SP,	min	15	15	17	20	25	35	40	45	50	55	60	60	65	75	80	90	100	110	120	120	135	150	170	190	190
K.M1.SP	max	25	25	30	35	40	55	60	70	75	85	90	95	100	110	120	135	150	170	190	190	210	230	260	290	320

The standard radial clearance of Precision SP is C1NA.

BEARING NOMENCLATURE



EXAMPLE: NN3008ASK.M.SP

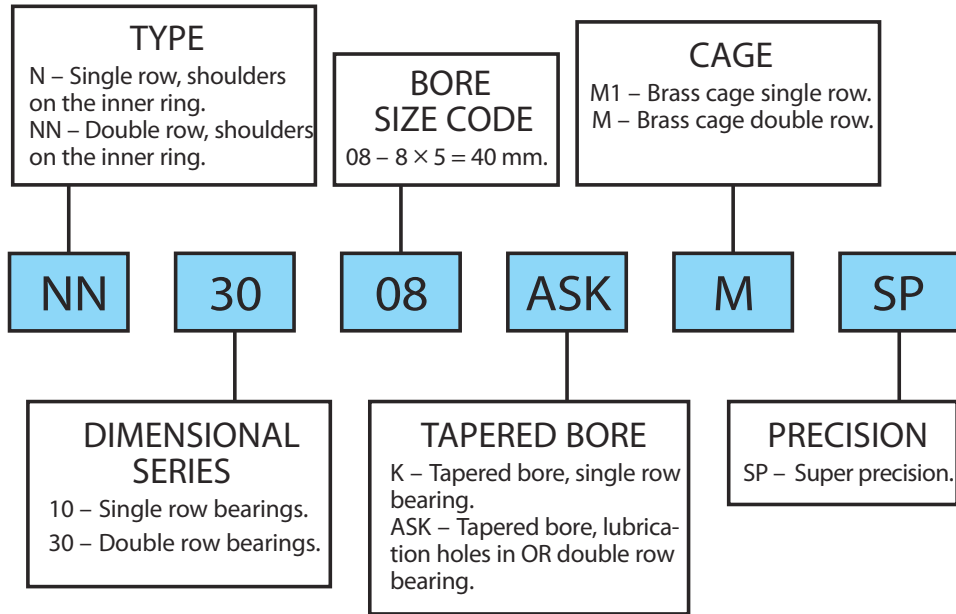

Table 3. Radial rigidity of cylindrical roller bearings.

Bore Reference Number	C _s N10 lb./μin.	C _s NN30 lb./μin.	Bore Reference Number	C _s N10 lb./μin.	C _s NN30 lb./μin.
05		3.2	28	8.3	17.4
06	1.8	3.8	30	9.2	18.5
07	2.3	4.4	32	9.3	19.7
08	2.5	5.3	34	10.4	21.2
09	2.8	6.1	36	11.0	22.7
10	3.3	6.6	38	11.5	23.5
11	3.7	7.3	40	11.8	24.8
12	4.0	7.9	44	13.2	26.8
13	4.2	8.3	48	14.3	28.9
14	4.6	9.3	52	15.2	31.6
15	4.8	9.7	56	16.5	33.1
16	5.1	10.4	60	17.8	33.3
17	5.3	11.2	64	18.7	36.2
18	5.8	11.3	68	20.3	40.3
19	6.0	11.8	72	21.1	41.7
20	6.2	12.2	76	21.9	43.2
21	6.5	13.0	80	23.0	48.7
22	7.0	14.0			
24	7.5	15.2			
26	8.0	16.7			

$$\delta_r = F_r / C_s$$

δ_r = radial deflection [μin.]

F_r = radial load [lb.]

C_s = rigidity [lb./μin.]

CYLINDRICAL ROLLER BEARINGS

N10

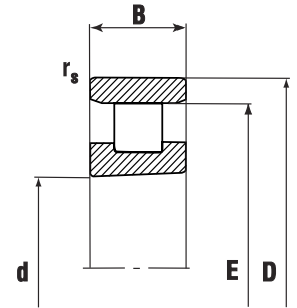

BEARING NUMBER	BEARING DIMENSIONS (in millimeters)					LOAD RATING		ATTAINABLE SPEED		WEIGHT
	d	D	B	r _{smin}	E	dyn. C	stat. C ₀	Grease rpm	Oil minimal	Weight ≈ lbs.
FAG						lbs.	lbs.			lbs.
N1006K.M1.SP	30	55	13	0.6	48.5	4,185	4,050	19,000	22,000	0.3
N1007K.M1.SP	35	62	14	0.6	55	5,310	5,512	16,000	18,000	0.4
N1008K.M1.SP	40	68	15	0.6	61	6,187	6,525	15,000	17,000	0.5
N1009K.M1.SP	45	75	16	0.6	67.5	7,312	7,987	13,000	15,000	0.6
N1010K.M1.SP	50	80	16	0.6	72.5	8,100	9,337	12,000	14,000	0.7
N1011K.M1.SP	55	90	18	1	80.5	9,337	11,250	11,000	13,000	1.0
N1012K.M1.SP	60	95	18	1	85.5	9,900	12,375	10,000	12,000	1.0
N1013K.M1.SP	65	100	18	1	90.5	10,125	13,162	9,500	11,000	1.1
N1014K.M1.SP	70	110	20	1	100	14,400	18,225	9,000	10,000	1.5
N1015K.M1.SP	75	115	20	1	105	14,737	19,125	8,500	9,500	1.6
N1016K.M1.SP	80	125	22	1	113.5	17,212	22,050	7,500	8,500	2.1
N1017K.M1.SP	85	130	22	1	118.5	17,550	23,400	7,500	8,500	2.3
N1018K.M1.SP	90	140	24	1.1	127	20,925	28,125	6,700	7,500	3.0
N1019K.M1.SP	95	145	24	1.1	132	21,712	29,025	6,300	7,000	3.1
N1020K.M1.SP	100	150	24	1.1	137	22,050	30,150	6,000	6,700	3.2
N1021K.M1.SP	105	160	26	1.1	145.5	25,200	34,425	5,600	6,300	4.0
N1022K.M1.SP	110	170	28	1.1	155	31,500	42,750	5,300	6,000	5.1
N1024K.M1.SP	120	180	28	1.1	165	33,750	46,800	5,000	5,600	5.4
N1026K.M1.SP	130	200	33	1.1	182	40,500	56,250	4,300	4,800	8.2
N1028K.M1.SP	140	210	33	1.1	192	41,175	59,625	4,000	4,500	8.7
N1030K.M1.SP	150	225	35	1.5	205.5	46,800	69,750	3,800	4,300	10.5
N1032K.M1.SP	160	240	38	1.5	220	55,125	79,875	3,400	3,800	12.8
N1034K.M1.SP	170	260	42	2.1	237	67,500	96,750	3,200	3,600	17.1
N1036K.M1.SP	180	280	46	2.1	255	81,000	117,000	3,000	3,400	22.5
N1038K.M1.SP	190	290	46	2.1	265	82,125	123,750	2,800	3,200	23.4
N1040K.M1.SP	200	310	51	2.1	281	90,000	135,000	2,600	3,000	30.9
N1044K.M1.SP	220	340	56	3	310	114,750	172,125	2,400	2,800	39.5
N1048K.M1.SP	240	360	56	3	330	121,500	191,250	2,200	2,600	42.5
N1052K.M1.SP	260	400	65	4	364	147,375	229,500	1,900	2,200	63.0
N1056K.M1.SP	280	420	65	4	384	153,000	247,500	1,800	2,000	68.1
N1060K.M1.SP	300	460	74	4	420	202,500	321,750	1,600	1,800	96.3
N1064K.M1.SP	320	480	74	4	440	205,875	337,500	1,500	1,700	99.4
N1068K.M1.SP	340	520	82	5	475	252,000	411,750	1,400	1,600	133.8
N1072K.M1.SP	360	540	82	5	495	256,500	427,500	1,300	1,500	142.0
N1076K.M1.SP	380	560	82	5	515	265,500	450,000	1,300	1,500	146.8



**BARDEN
PRECISION
BEARINGS**

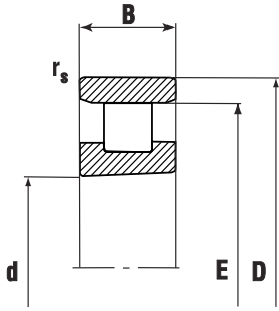

BEARING NUMBER	BEARING DIMENSIONS (in millimeters)					LOAD RATING		ATTAINABLE SPEED		WEIGHT
	d	D	B	r_{smin}	E	dyn. C lbs.	stat. C_0 lbs.	Grease rpm	Oil minimal	Weight ≈ lbs.
FAG										
N1080K.M1.SP	400	600	90	5	550	308,250	522,000	1,200	1,400	194.2
N1084K.M1.SP	420	620	90	5	570	315,000	551,250	1,100	1,300	199.9
N1088K.M1.SP	440	650	94	6	597	351,000	618,750	1,100	1,300	233.7
N1092K.M1.SP	460	680	100	6	624	373,500	675,000	1,000	1,200	264.5
N1096K.M1.SP	480	700	100	6	644	382,500	697,500	950	1,100	275.6
N10/500K.M1.SP	500	720	100	6	664	396,000	720,000	950	1,100	286.6

CYLINDRICAL ROLLER BEARINGS

NN30

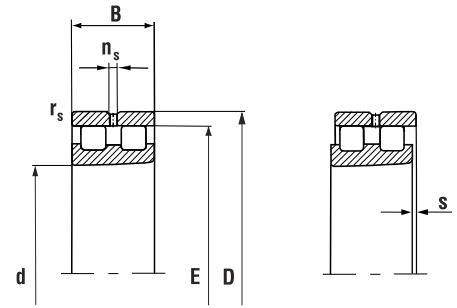

BEARING NUMBER	BEARING DIMENSIONS (in millimeters)							LOAD RATING		ATTAINABLE SPEED		WEIGHT
	d	D	B	r _{smin}	E	n _s	s	dyn. C	stat. C ₀	Grease rpm	Oil rpm	Weight ≈ lbs.
FAG								lbs.	lbs.			lbs.
NN3006ASK.M.SP	30	55	19	1	48.5	4.8	1.4	6,525	7,650	16,000	19,000	0.4
NN3007ASK.M.SP	35	62	20	1	55	4.8	1.4	7,987	9,900	14,000	17,000	0.6
NN3008ASK.M.SP	40	68	21	1	61	4.8	1.4	10,125	13,162	12,000	15,000	0.7
NN3009ASK.M.SP	45	75	23	1	67.5	4.8	1.7	12,150	16,200	11,000	14,000	0.9
NN3010ASK.M.SP	50	80	23	1	72.5	4.8	1.7	12,825	18,000	10,000	13,000	0.9
NN3011ASK.M.SP	55	90	26	1.1	81	4.8	1.9	16,200	22,500	9,000	11,000	1.4
NN3012ASK.M.SP	60	95	26	1.1	86.1	4.8	1.9	16,875	24,750	8,500	10,000	1.4
NN3013ASK.M.SP	65	100	26	1.1	91	4.8	1.9	17,212	26,100	8,000	9,500	1.6
NN3014ASK.M.SP	70	110	30	1.1	100	6.5	2.3	22,050	33,750	7,000	8,500	2.4
NN3015ASK.M.SP	75	115	30	1.1	105	6.5	2.3	22,500	35,100	6,700	8,000	2.5
NN3016ASK.M.SP	80	125	34	1.1	113	6.5	2.5	27,000	41,850	6,300	7,500	3.4
NN3017ASK.M.SP	85	130	34	1.1	118	6.5	2.5	28,125	45,000	6,000	7,000	3.6
NN3018ASK.M.SP	90	140	37	1.5	127	6.5	2.5	31,500	50,400	5,600	6,700	4.7
NN3019ASK.M.SP	95	145	37	1.5	132	6.5	2.5	32,175	53,100	5,300	6,300	4.9
NN3020ASK.M.SP	100	150	37	1.5	137	6.5	2.5	32,850	55,125	5,300	6,300	5.1
NN3021ASK.M.SP	105	160	41	2	146	6.5	2.6	42,750	69,750	4,800	5,600	6.5
NN3022ASK.M.SP	110	170	45	2	155	6.5	2.8	49,500	81,000	4,500	5,300	8.3
NN3024ASK.M.SP	120	180	46	2	165	6.5	3.1	52,200	87,750	4,300	5,000	9.0
NN3026ASK.M.SP	130	200	52	2	182	9.5	3.3	65,250	112,500	3,800	4,500	13.3
NN3028ASK.M.SP	140	210	53	2	192	9.5	3.3	67,500	117,000	3,600	4,300	14.3
NN3030ASK.M.SP	150	225	56	2.1	206	9.5	3.7	75,375	131,625	3,400	4,000	17.4
NN3032ASK.M.SP	160	240	60	2.1	219	9.5	4.2	84,375	150,750	3,200	3,800	21.1
NN3034ASK.M.SP	170	260	67	2.1	236	9.5	4.5	101,250	180,000	3,000	3,600	28.7
NN3036ASK.M.SP	180	280	74	2.1	255	12.2	4.8	128,250	225,000	2,800	3,400	37.5
NN3038ASK.M.SP	190	290	75	2.1	265	12.2	4.8	131,625	234,000	2,600	3,200	39.7
NN3040ASK.M.SP	200	310	82	2.1	282	12.2	5.3	147,375	270,000	2,400	3,000	50.7
NN3044ASK.M.SP	220	340	90	3	310	15	5.5	180,000	328,500	2,200	2,800	72.5
NN3048ASK.M.SP	240	360	92	3	330	15	6	191,250	351,000	2,000	2,600	79.4
NN3052ASK.M.SP	260	400	104	4	364	15	6.5	238,500	450,000	1,900	2,400	105.8
NN3056ASK.M.SP	280	420	106	4	384	15	6.8	243,000	468,000	1,800	2,200	114.0
NN3060ASK.M.SP	300	460	118	4	418	17.7	7.4	285,750	540,000	1,600	1,900	157.6
NN3064ASK.M.SP	320	480	121	4	438	17.7	7.9	297,000	585,000	1,600	1,900	170.2
NN3068ASK.M.SP	340	520	133	5	473	17.7	8.7	366,750	731,250	1,400	1,700	227.1
NN3072ASK.M.SP	360	540	134	5	493	17.7	8.7	373,500	753,750	1,400	1,700	240.3
NN3076ASK.M.SP	380	560	135	5	513	17.7	9	382,500	776,250	1,300	1,600	251.3



**BARDEN
PRECISION
BEARINGS**

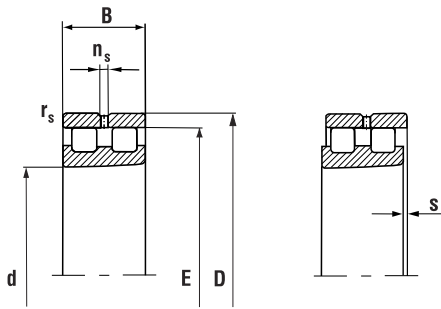

BEARING NUMBER	BEARING DIMENSIONS (in millimeters)							LOAD RATING		ATTAINABLE SPEED		WEIGHT
	d	D	B	r _{smin}	E	n _s	s	dyn. C lbs.	stat. C ₀ lbs.	Grease rpm	Oil rpm	Weight ≈ lbs.
FAG												
NN3080ASK.M.SP	400	600	148	5	549	17.7	9.5	486,000	1,012,500	1,200	1,500	328.5
NN3084ASK.M.SP	420	620	150	5	569	17.7	10	477,000	1,012,500	1,200	1,500	343.9
NN3088ASK.M.SP	440	650	157	6	597	23.5	10.3	551,250	1,147,500	1,100	1,400	394.6
NN3092ASK.M.SP	460	680	163	6	624	23.5	10.5	585,000	1,215,000	1,100	1,400	449.7
NN3096ASK.M.SP	480	700	165	6	644	23.5	11	607,500	1,316,250	1,000	1,300	471.8
NN30/500ASK.M.SP	500	720	167	6	664	23.5	11.5	596,250	1,316,250	1,000	1,300	491.6

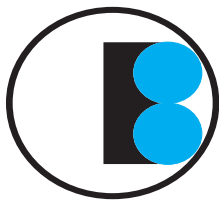

The Barden Corporation

A Member of the Schaeffler Group

...Insist on Precision

200 Park Avenue
P.O. Box 2449
Danbury, CT 06813-2449
www.bardenbearings.com